



\ SCIA ENGINEER
ADVANCED TRAINING
Integration with BIM workflows

All information in this document is subject to modification without prior notice. No part of this manual may be reproduced, stored in a database or retrieval system or published, in any form or in any way, electronically, mechanically, by print, photo print, microfilm or any other means without prior written permission from the publisher. SCIA is not responsible for any direct or indirect damage because of imperfections in the documentation and/or the software.

© Copyright 2024 SCIA nv. All rights reserved.

Table of Contents

Table of Contents	3
Introduction	5
Modules	5
Other applications	5
Chapter 1: Analytical model versus structural model	6
1.1. Different representations explained	6
1.2. Generating the structural model in SCIA Engineer	6
1.2.1. Mode.....	7
1.2.2. Priority.....	8
1.2.3. Alignment and eccentricities.....	8
1.2.4. Gaps/Cuts.....	8
1.2.5. Example with advanced settings.....	9
Chapter 2: Open BIM & IFC	10
2.1. Open BIM & IFC	10
2.1.1. OpenBIM.....	10
2.1.2. IFC format.....	10
2.2. IFC exchange in SCIA Engineer	11
2.2.1. Shape representations.....	11
2.2.2. Profile definitions.....	12
2.3. Export IFC	13
2.3.1. IFC/BIM Properties.....	13
2.3.2. Available file formats.....	14
2.3.3. Exporting an IFC from SCIA Engineer.....	14
2.3.4. Export of specific elements or geometry.....	16
2.4. Import (or Update) IFC	17
2.4.1. IFC/BIM Properties.....	17
2.4.2. Available file formats.....	17
2.4.3. Importing (or Updating) an IFC in SCIA Engineer.....	17
2.4.4. Import of specific elements or geometry.....	21
2.5. BIM Toolbox	22
2.5.1. Convert.....	22
2.5.2. Align.....	23
2.6. Exchange with BIMPLUS or BIMCloud	28
Chapter 3: Exchange via the Revit-link	33
3.1. Installation of the Revit-link	33
3.2. Overview	35
3.3. Exchange from Revit to SCIA	37
3.3.1. Generating the analytical model in Revit.....	37
3.3.2. Exporting the model to SCIA Engineer.....	40
3.3.3. Managing the mapping tables.....	44
3.3.4. Opening the model in SCIA Engineer.....	47
3.4. Exchange from SCIA to Revit	48
3.4.1. Exporting the model to Revit.....	48
3.4.2. Opening the model in Revit.....	49
Chapter 4: Exchange via the Tekla-link	52
4.1. Installation of the Tekla-link	52
4.2. Overview	55
4.3. Exchange from Tekla to SCIA	56

4.3.1.	Generating the analytical model in Tekla	56
4.3.2.	Exporting the model to SCIA Engineer	58
4.3.3.	Opening the model in SCIA Engineer	62
4.4.	Exchange from SCIA to Tekla.....	63
4.4.1.	Exporting the model to Tekla Structures.....	63
4.4.2.	Opening the model in Tekla Structures.....	64

Introduction

The construction industry is split up in many separate providers, from designers up to building part suppliers; each party is using software for different tasks (design, costs, detailing, fabrication...). Today we are aware that a major part of the inefficiency in construction is due to inadequate cooperation between the construction partners, resulting in errors, repetitive work, extra costs etc.

There are solutions to fundamentally improve the cooperation between construction partners, even with each party keeping its own existing software. If we agree on how to exchange information, if we use digital 3D models of structures, if we use standard exchange formats and if we can control the workflow between project partners, then we all win.

This manual will explain the different methods for exchanging BIM models with SCIA Engineer and discuss the possible workflows and correct procedures to have a good model exchange.

Modules

The SCIA license modules that are needed for exchanging certain data to and from SCIA Engineer are:

MODULE	CODE	INCLUDED IN	LINK TO RESOURCE CENTRE
Revit link	Sen.11	Concept edition Professional edition Expert edition Ultimate edition - Can be purchased as separate module	https://www.scia.net/en/resource/fact-sheet/interoperability-bim/sen11-revit-link
Tekla link	Sen.12	Steel edition Concept edition Professional edition Expert edition Ultimate edition - Can be purchased as separate module	https://www.scia.net/en/resource/fact-sheet/interoperability-bim/sen12-tekla-link
BIM toolbox*	Sen.10	Steel edition Concept edition Professional edition Expert edition Ultimate edition Precast edition - Can be purchased as separate module	https://www.scia.net/en/resource/fact-sheet/interoperability-bim/sen10-bim-toolbox

No additional modules are needed for import/export of these file formats: XML, DNF, FGBM, SAF, Bimplus, BIM Cloud, IFC, IFC compressed, Allplan (IFC), SDS/2, CEA plant-4D, Stepsteel, or graphic formats like jpg, dwg, dxf, pdf and others.
 (*) The BIM toolbox is still available but it's more efficient to turn to the SCIA Autoconverter.

Other applications

Another SCIA application that can assist in the exchange of BIM models to SCIA Engineer, is the SCIA Autoconverter. IFC-models can easily be converted to an analytical model (SAF-format) to use in SCIA Engineer.



APPLICATION	PACKAGE	LINK TO WEB PAGE
Scia Autoconverter	Annual subscription Includes Allplan Bimplus Professional with 3 users <ul style="list-style-type: none"> • Issue management • Validation process • CAD AddOn • API • BIM attribute management 	https://www.scia.net/en/software/scia-autoconverter

Chapter 1: Analytical model versus structural model

There are several different representations of a model to be considered in each project. The two representations we are dealing with in SCIA Engineer are the analytic model and the structural model. It's important to know and understand this, since every export or exchange option uses only one of these representations.

1.1. Different representations explained

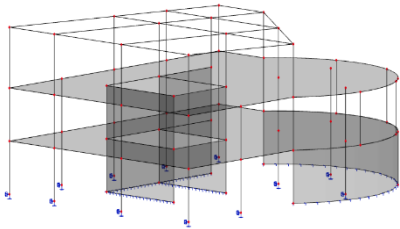

The **analytical model** is used for calculations. It is a model in which a beam or column is represented by a single line. The cross-section that belongs to that beam or column is assigned to that line, and thus the properties of that beam or column are assigned to that line as well. A plate or wall in the analytical model is represented by a plane with no thickness, but the information about the material and the thickness of the plate or wall are also assigned to that plane.

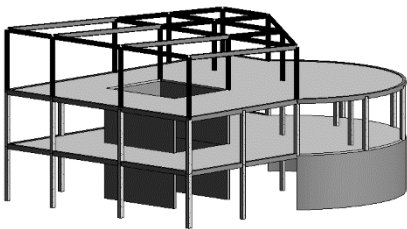

The **structural model** shows the volumes and shows how the structure will be built, so the elements are connected to each other in a realistic way. It can be used for construction drawings amongst other things. In SCIA Engineer, it's possible to generate this representation. Of course, the correct settings need to be used to ensure generating it correctly. In order to see it, you must activate the functionality for the structural model. In modelling software like Revit and Tekla, the emphasis lies on this volumetric representation.

SCIA, being calculation software, mainly uses the analytical model. When exchanging models between SCIA and Revit or Tekla using the plugins, the analytical model is being exchanged and it is very important to make sure it is properly constructed. The IFC format, however, uses the structural model.

Some modelling programs offer the possibility to generate the analytical model, but this does not necessarily ensure a *good* underlying analytical model at all. As you can see in this figure, a good-looking structural model can contain a very bad underlying analytical model. The beam is clearly not connected to the columns in the analytical model.

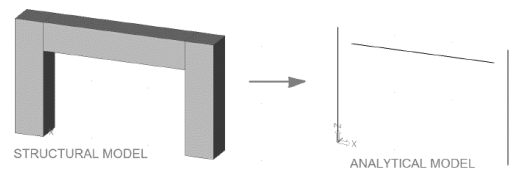

1.2. Generating the structural model in SCIA Engineer

In order to generate the structural model in SCIA Engineer, you must activate the functionality for the structural model in the project settings dialog.

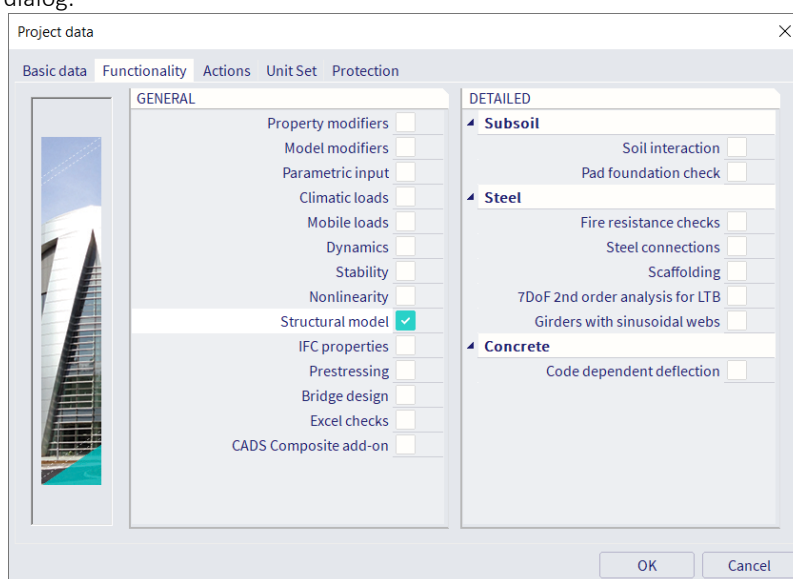

The structural model can then be activated, either via the visualisation options or the view settings from the context menu (right click).

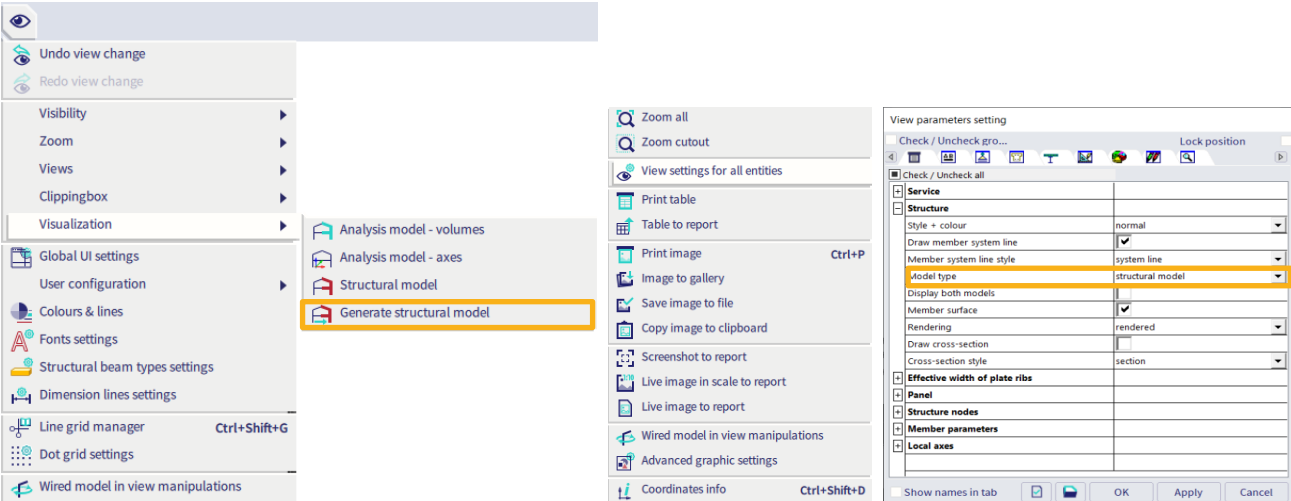

When the structural model functionality is activated, the properties window will show a section for the structural model (in advanced mode, so be sure to have all properties unfolded by showing the red arrow on the top right). Priorities, alignments, eccentricities and gaps or cuts can be defined here.

The principles are explained below. All settings are explained in detail on help.scia.net > Modelling > Geometry > Structural model.

1.2.1. Mode

Three mode options are available, with varying degrees of settings that will be automatically handled by the software or must be defined manually.

- **General:** Only one checkbox can be changed to lock the geometry. This mode is most suitable for members with special geometry (like solids with openings in them for instance). Imported members often have this mode by default, but this can cause unwanted behaviour when the members are exported again to IFC.
- **Automatic:** Settings are taken 'automatically' from the member definition. Default values are shown but can be changed manually.
- **Manual:** This mode follows the same logic as 'Automatic', but more options are now available for end-cuts.

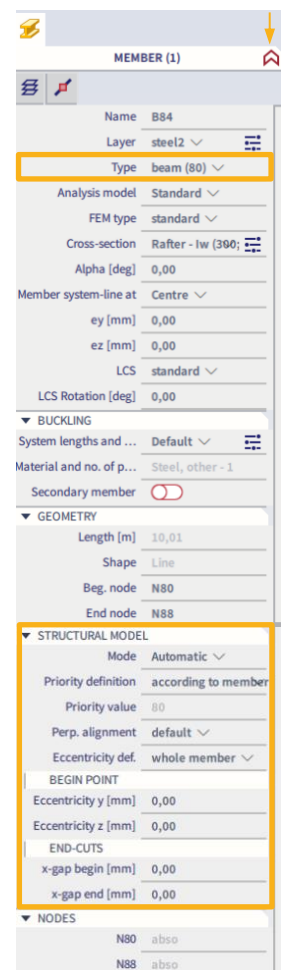

1.2.2. Priority

Note that the type of a member plays a role in the default priority settings. These are defined by the number between brackets, 80 in the example on the previous page. The priority can be changed by choosing another type or overwriting the priority in the structural model section.

To explain this behaviour, let's look at the following examples:



The first picture shows the visualisation of the analytical model, where the column and beam are simply drawn to the node.

The second picture shows the structural model, with priority 80 for the beam and 100 for the column. Note that the shape and orientation of the cross-section are taken into account to connect the members.

In the third picture, the priority is 100 for the beam and 80 for the column. The beam is now drawn on top of the column.

1.2.3. Alignment and eccentricities

With the alignment, you can change the way the member is drawn with respect to the member system line of the analytical model. They are drawn the same way by default. The line is usually in the centre of the cross-section. You can change this so for example the member is drawn under this line, with the value 'Top' for the alignment as shown in the picture below. Or you can define the eccentricity values manually, for instance to -80mm as shown below. Note that these changes only affect the structural model, so the eccentricities will not generate additional internal forces in the structure when calculating. This can be used when some members are for instance lower than other members, without changing the analysis model.

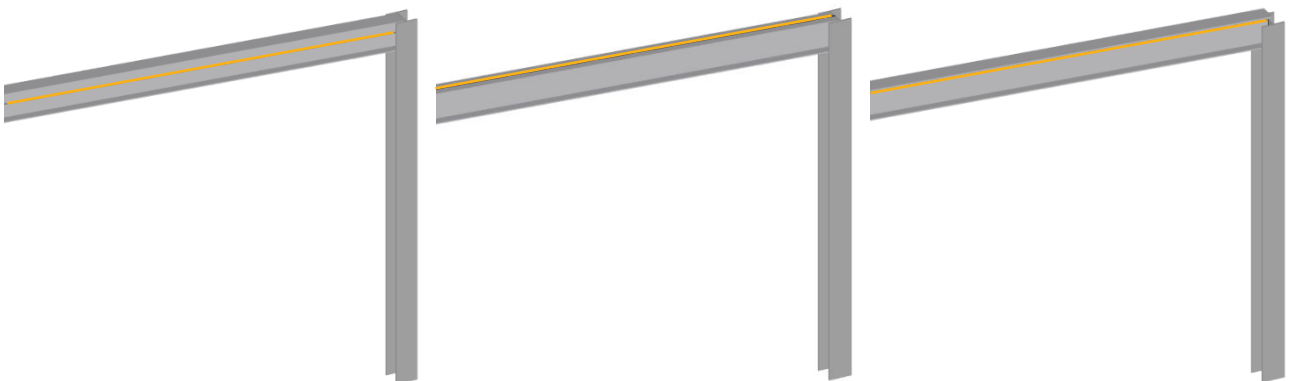

1.2.4. Gaps/Cuts

With end-cuts, you can define the end detail of the profile manually. A regeneration of the structural model is necessary before the changes are visible. In the example below, the structure is shown without gap first, and secondly, a gap of 50 mm is defined between the end of the beam and the column.

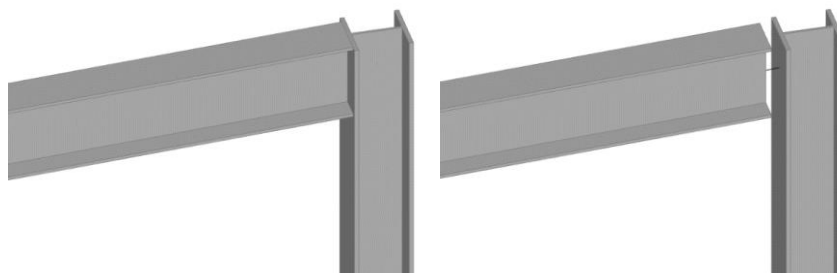

1.2.5. Example with advanced settings

As an example, the following structural model can be achieved with the setting for end-cuts and eccentricities shown below. (The columns are 3,6m high, the beam is 3m long.) The orange lines show the analytical model, the volumes are shown for the structural model. Please pay attention to the way the members are connected in blue.

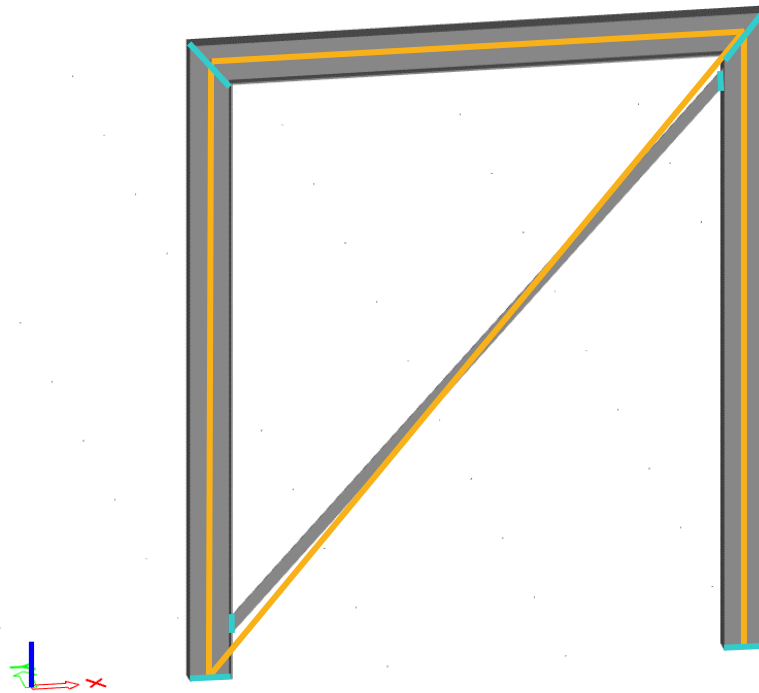

Beam		Bracing	
STRUCTURAL MODEL		STRUCTURAL MODEL	
Mode	Manual	Mode	Manual
Priority definition	defined manually	Priority definition	according to member
Priority value	100	Priority value	80
Perp. alignment	default	Perp. alignment	default
Eccentricity def.	whole member	Eccentricity def.	each endpoint
BEGIN POINT		BEGIN POINT	
Eccentricity y [mm]	0,00	Eccentricity y [mm]	0,00
Eccentricity z [mm]	0,00	Eccentricity z [mm]	100,00
END-CUTS		END POINT	
begin x-offset [mm]	0,00	Eccentricity y [mm]	0,00
begin Rz [deg]	0,00	Eccentricity z [mm]	-100,00
begin Ry [deg]	45,00	END-CUTS	
end x-offset [mm]	0,00	begin x-offset [mm]	178,00
end Rz [deg]	180,00	begin Rz [deg]	0,00
end Ry [deg]	135,00	begin Ry [deg]	132,00
		end x-offset [mm]	407,00
		end Rz [deg]	0,00
		end Ry [deg]	132,00

Detailed information for each setting of the structural model can be found on: help.scia.net > Modelling > Geometry > Structural model.

Chapter 2: Open BIM & IFC

2.1. Open BIM & IFC



2.1.1. OpenBIM

OpenBIM^{®1} extends the benefits of BIM (Building Information Modeling) by improving the accessibility, usability, management, and sustainability of digital data in the built asset industry. At its core, openBIM is a collaborative process that is vendor neutral. openBIM processes can be defined as sharable project information that supports seamless collaboration for all project participants. openBIM facilitates interoperability to benefit projects and assets throughout their lifecycle.

OpenBIM ensures that:

1. **Interoperability** is key to the digital transformation in the built asset industry
2. **Open** and neutral standards should be developed to facilitate interoperability
3. **Reliable** data exchanges depend on independent quality benchmarks
4. **Collaboration** workflows are enhanced by open and agile data formats
5. **Flexibility** of choice of technology creates more value to all stakeholders
6. **Sustainability** is safeguarded by long-term interoperable data standards

Open BIM is a universal approach to the collaborative design, realization and operation of buildings based on open standards and workflows. Open BIM is an initiative of BuildingSMART and several leading software vendors using the open BuildingSMART Data Model.

2.1.2. IFC format

At its core, buildingSMART enables the entire built asset industry to improve the sharing of information throughout the lifecycle of project or asset. By breaking down the silos of information, end users can better collaborate and cooperate regardless of which software application they are using. buildingSMART’s technical core is based around Industry Foundation Classes (IFC) which was ISO certified in 2013.

IFC is a standardized, digital description of the built asset industry. It is an open, international standard (ISO 16739-1:2018) and promotes vendor-neutral, or agnostic, and usable capabilities across a wide range of hardware devices, software platforms, and interfaces for many different use cases.

Industry Foundation Classes, IFC, are the main BuildingSMART data model standard to facilitate interoperability in the architecture, engineering, and construction (AEC) industry. The IFC format is registered by ISO as ISO/PAS 16739. IFC is used to exchange and share BIM data between applications developed by different software vendors without the software having to support numerous native formats.



IFC2x3 CV2.0

BuildingSMART International awarded SCIA nv as the first company to pass the certification of the interoperability standard IFC 2x3 “Version 2.0” for structural model exchange with SCIA Engineer, as was announced during the international BuildingSMART meeting in Waltham (Boston, USA), 11-15 March 2013.

Vendor	Product	Schema	Exchange Requirement	Import / Export	Status	Started	Completed	Report (link)
NEMETSCHek Scia	Scia Engineer	IFC 2x3	CV 2.0	Import	Finished	2010-07-13	2013-09-17	https://ifc2x3.b-cert.org/ords/ifc/certification/getCertificationReport/201
NEMETSCHek Scia	Scia Engineer	IFC 2x3	CV2.0-Struct	Export	Finished	2010-07-13	2013-04-16	https://ifc2x3.b-cert.org/ords/ifc/certification/getCertificationReport/104

The newer IFC4 format is supported only for import in SCIA for now. Reference View and Data Transfer View are supported. In general, all entities and representations which are supported in IFC2x3 are supported. Additionally, the new shape representation that was introduced, Tessellation, is also supported in SCIA Engineer.

The status of IFC4 support in SCIA Engineer can be found on: help.scia.net > Data exchange > IFC > Support of IFC4.

¹ Source of all information on this page: <https://www.buildingsmart.org/about/openbim/>

2.2. IFC exchange in SCIA Engineer

2.2.1. Shape representations

Elements can be represented in different ways in the IFC-format. Each representation has its own purpose and advantages. Some of these representations are shown here to understand the import possibilities and effects of the export settings that are available.

SweptSolid/AdvancedSweptSolid

A profile (1D element) or flat element (2D element) represented by a SweptSolid is defined and extruded along a curve or axis. Elements with this representation can be converted to native SCIA Engineer members after import.

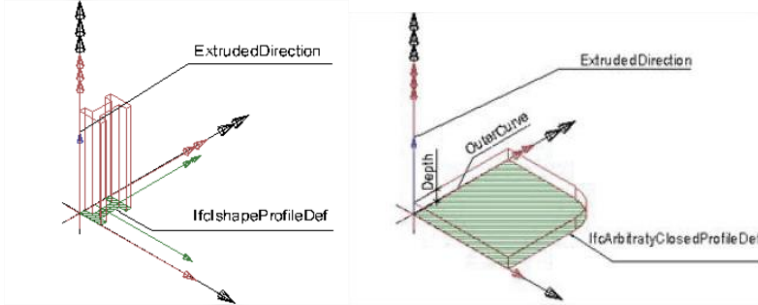

Objects with this representation can contain information/properties about the geometry such as cross-section, thickness etc.

Clipping

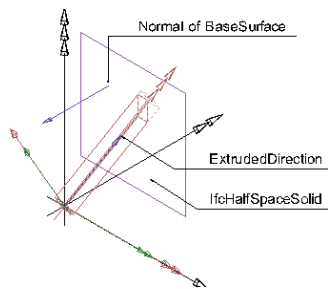

An element created by a difference between swept area solids is represented by 'Clipping'.

Elements with this representation can be converted to native SCIA Engineer members after import, with a defined structural model representation.

Boundary representation / Brep

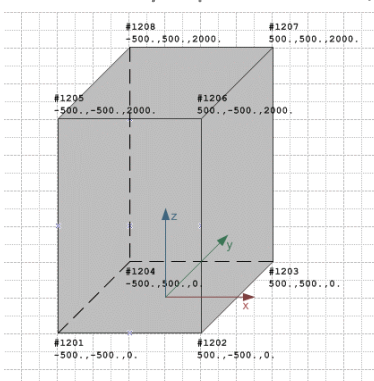

An element represented by a Brep is described with vertices, interconnected with lines, in order to define a volume. This is most useful for complex geometry that isn't easy to represent using other definitions.

These entities are imported into SCIA Engineer as general volumes (general solids). In this case, there is a possibility to use the member recognizer functionality to convert them to native SCIA Engineer members. This representation lacks information about thickness, cross-section etc.

CSG

Like 'Clipping' for SweptSolids, a CSG representation is the result of a difference between solid elements. These entities are also imported into SCIA Engineer as general volumes (general solids).

Sectioned spine

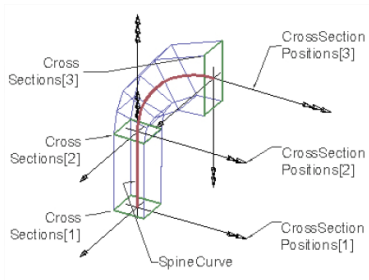

Elements with haunches or arbitrary profiles can be represented by a sectioned spine. A sectioned spine is a representation of the shape of a three-dimensional object composed by a number of planar cross sections, and a spine curve. The shape is defined between the first element of cross sections and the last element of the cross sections.

Rules that are followed for exporting specific elements according to their possible shape representations can be found on help.scia.net > Data exchange > IFC > Ifc file format extension.

2.2.2. Profile definitions

SCIA Engineer supports the following IFC classes for profile definition:

- | | | |
|---|---|---|
| <ul style="list-style-type: none"> • IfcArbitraryClosedProfileDef • IfcArbitraryClosedProfileDefWithVoids • IfcCompositeProfileDef • IfcDerivedProfileDef • IfcCenterLineProfileDef | } | <p>These can be imported as native SCIA cross-sections.</p> |
| <ul style="list-style-type: none"> • IfcAsymmetricIShapeProfileDef • IfcCShapeProfileDef • IfcCircleHollowProfileDef • IfcCircleProfileDef • IfcCraneRailAShapeProfileDef • IfcCraneRailFShapeProfileDef • IfcIShapeProfileDef • IfcLShapeProfileDef • IfcRectangleHollowProfileDef • IfcRectangleProfileDef • IfcTShapeProfileDef • IfcUShapeProfileDef • IfcZShapeProfileDef | } | <p>These can be imported as parametric cross-sections.</p> |

Other profiles will be imported as general cross-sections in SCIA Engineer.

Rules that are followed for exporting specific elements according to their possible profile definitions can be found on help.scia.net > Data exchange > IFC > Ifc file format extension.

2.3. Export IFC

A model in SCIA Engineer can be exported to IFC. Remember that it is the structural model, which is exported, as mentioned in chapter 1. To see the model in the way it will be exported, it is therefore useful to generate the structural model view in SCIA Engineer. Please pay special attention to the 'Mode' in which the element is generated in the structural model, as mentioned in section 1.2.1.

2.3.1. IFC/BIM Properties

The functionality 'IFC properties' can be switched on in the Project Data. A group of BIM related properties then appears in the properties window. It has two main parts. The first section has advanced options for export. The general export settings can be overwritten here for specific elements. The other one is a subgroup 'Attributes'.

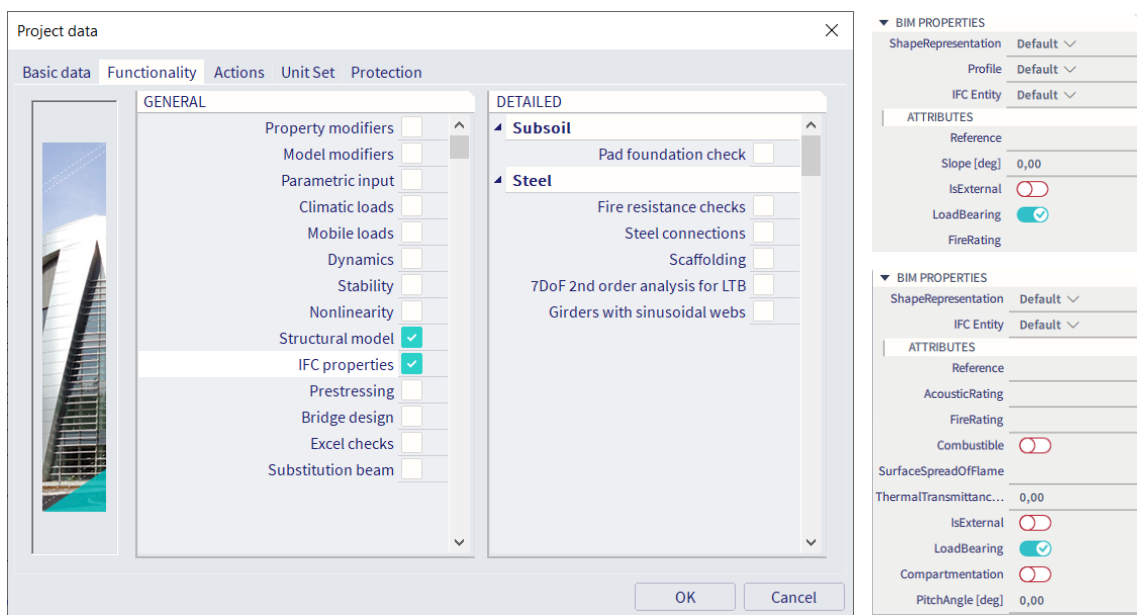

Export options

The advanced export options are different for different elements, e.g., 'Profile' is only there for straight 1D members with SweptSolid geometry. The element is exported using the setting in the BIM properties instead of by the rules defined in the export dialog. If the value is set to default, that means the element is exported by the rules defined in the export dialog.

ShapeRepresentation and **Profile** represent the specific export settings for elements as explained in the previous section of this manual.

The IFC Entity can change the object type of the element in the IFC. For instance, a shell is exported as IfcSlab by default, but you can choose here to export it as IfcWall.

Attributes

Additional information can be attached to an IFC Entity by means of a 'PropertySet'. SCIA Engineer support the '*Common' property sets and their standard properties for all 1D members exported as IfcBeam, IfcMember or IfcColumn, all 2D members exported as IfcWallStandardCase or IfcSlab and all general volumes exported as IfcWall. This means some additional properties can be assigned and will be visible in the IFC in the PropertySet Pset_BeamCommon for beams, Pset_WallCommon for walls etc.

2.3.2. Available file formats

IFC and IFCzip

SCIA Engineer supports both plain IFC and IFCzip for export. The IFCzip file format is a zipped plain IFC. The packing and unpacking during export and import is done automatically by SCIA Engineer.

Allplan

Since version 15.2, a special export option allows the users to export an IFC file with predefined settings for Allplan. The exported file is a plain IFC which is exported according to Allplan user needs.

2.3.3. Exporting an IFC from SCIA Engineer

Before exporting, be aware if you have an active selection. If a selection of certain members is active, only these elements will be exported.

The model can be exported from the menu:

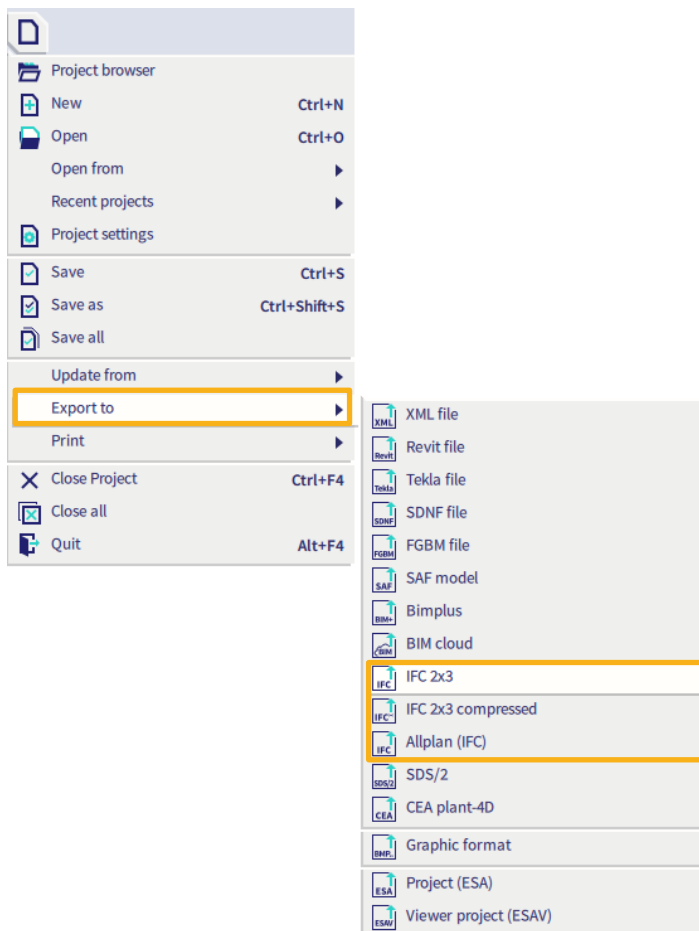

A dialog will open to choose a file location and name:

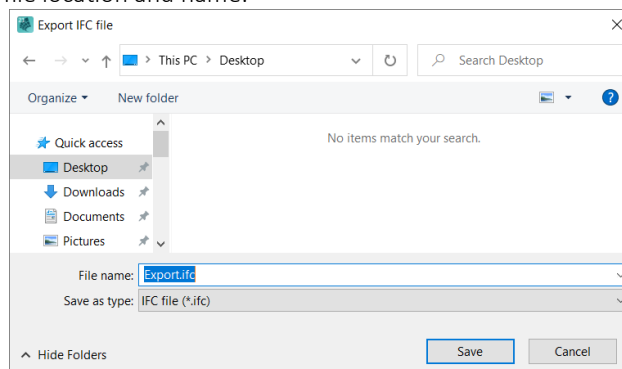

You can choose the view definition 'Coordination View' or 'Simplified View'. The first one allows you to choose the representation per member type. The second one exports everything in brep representation. The units in which the model is exported can be chosen, and certain member types can be included or excluded from the export.

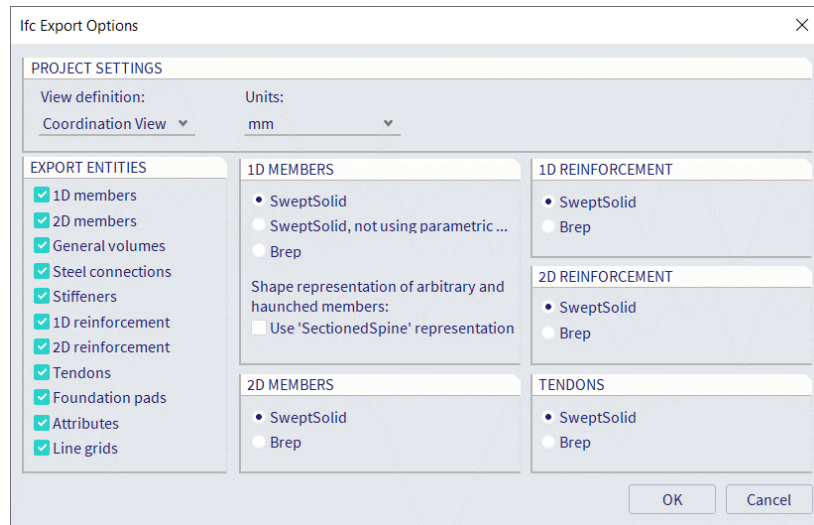

After confirmation, a report will be shown for the export process. This shows the number of exported entities and errors or notifications.

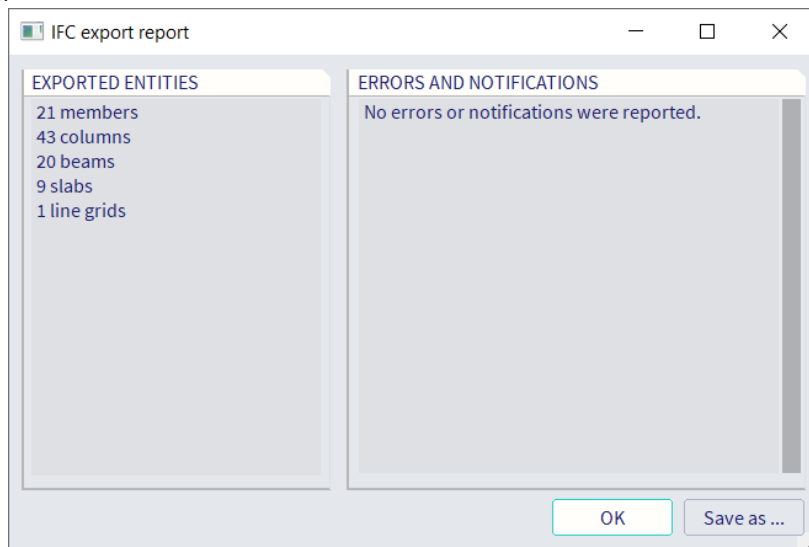

2.3.4. Export of specific elements or geometry

Openings and subregions

All **openings in 1D members** are exported as IfcOpeningElement with a parametric or general profile. If the repetition is set, all openings are exported as separated objects.

Openings and subregions in 2D elements are exported as an IfcOpeningElement of type 'opening' or 'recess'. The subregion thickness must be lower than the thickness of the main slab/wall. In case the subregion is thicker than the slab/wall, the subregion is not taken in account and the model is exported without the subregion.

When the opening in 2D member is modelled as a cut-out, no opening element is exported. This means that for elements with a SweptSolid representation, an entire member is exported (without cut-outs). For Brep, the correct shape (with cut-outs) is exported.

Steel connection parts

SCIA Engineer supports export of **flat steel connection parts, cleats, and stiffeners** to IFC as independent plates (IfcPlate). Information about a **weld** (IfcFastener entity) and **bolts** (IfcMechanicalFastener entity) are also exported. Each plate has a material as assigned in SCIA Engineer. **Plates** are exported as SweptSolid or Brep whereas bolts are only exported as Brep. All bolts in a **bolt assembly** are defined as mapped items.

Concrete reinforcement

The default export of **concrete reinforcement** and **free bars** is done by means of the AdvancedSweptSolid representation. In case you export it as Brep, all reinforcement is exported with boundary representation.

Note: **1D concrete reinforcement** is exported with overlapping anchorage. This can cause problems during import in some applications. A workaround is to explode the reinforcements in free bars in SCIA before exporting.

Concrete 1D member reinforcement and free bars are always exported as IfcReinforcingBar. Free bars which have defined a repetition and stirrups are exported as one reinforcing bar with mapped items. 2D Reinforcement is always exported as IfcReinforcingMesh.

Building storeys

The current SCIA Engineer version fully supports export and import of **building storeys**. If storeys are defined in a project, then all members are assigned to the storey in which they are located. If a member is allocated in more storeys, then it is exported only to the first one. If a member is allocated to no storey, then it is assigned to the building itself. In case no storey exists in the project, no building storey is exported to the IFC file and all members are assigned to the building.

Line grids

Only **circular and rectangular 2D line grids**, and **rectangular 3D line grids** are exported. The rectangular 3D line grid is exported as a set of 2D line grids because the IFC file format does not support a 3D grid.

2.4. Import (or Update) IFC

2.4.1. IFC/BIM Properties

The functionality 'IFC properties' can be switched on in the Project data, but is also switched on by default after IFC file import. Any additional information related to specific elements, that was exported in the IFC, can be viewed in these properties.

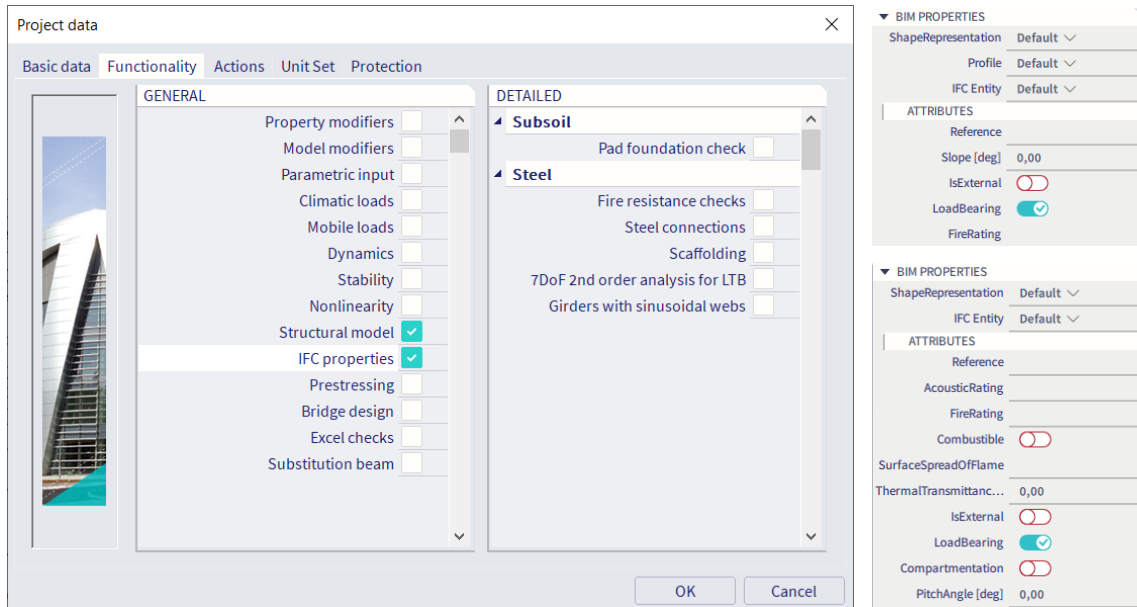

2.4.2. Available file formats

SCIA Engineer supports both plain IFC and IFCzip for import. During import, it is automatically recognized if it is the plain IFC or the zipped one. Therefore, the same function is used.

2.4.3. Importing (or Updating) an IFC in SCIA Engineer

IFC files can be opened in SCIA Engineer. This can be done in two ways, by importing or updating. Importing will open a new, empty project and open the IFC. Updating will use the current project in SCIA Engineer, apply changes from the IFC file while keeping as much as possible from the existing project, like load cases and combinations for example.

Importing or updating an IFC in SCIA Engineer can be done from the menu:

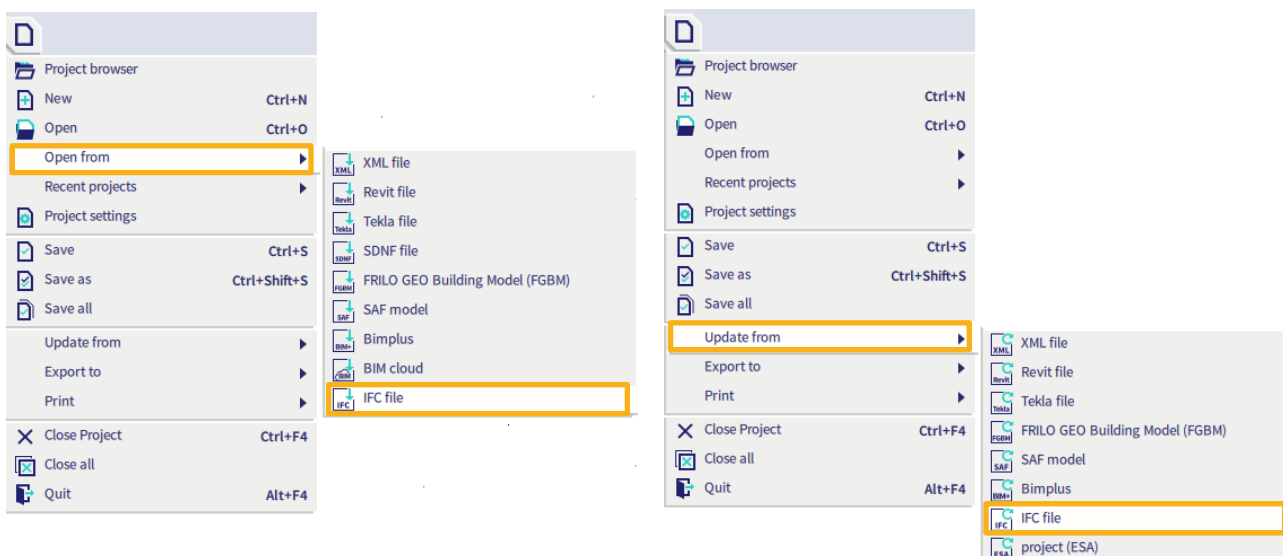

A dialog will open to browse for the IFC file:

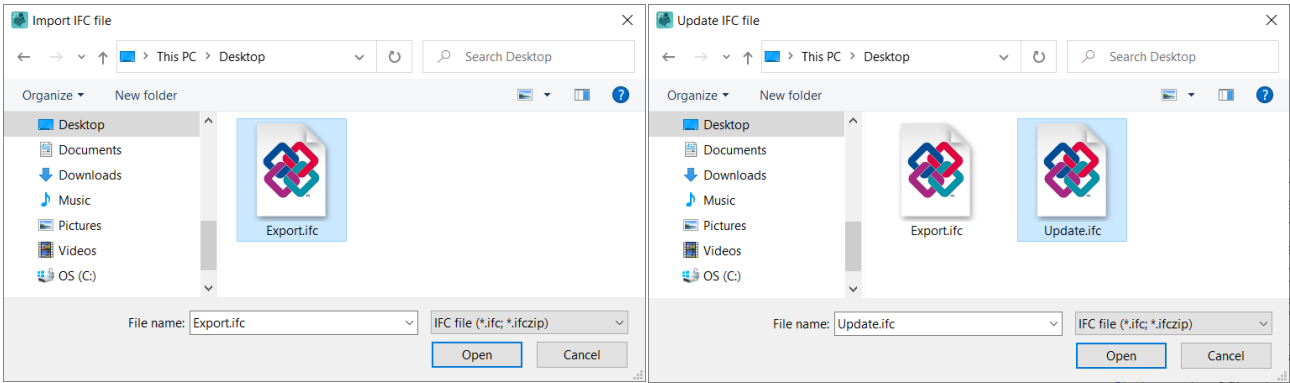

You can now choose how to import/update the model:

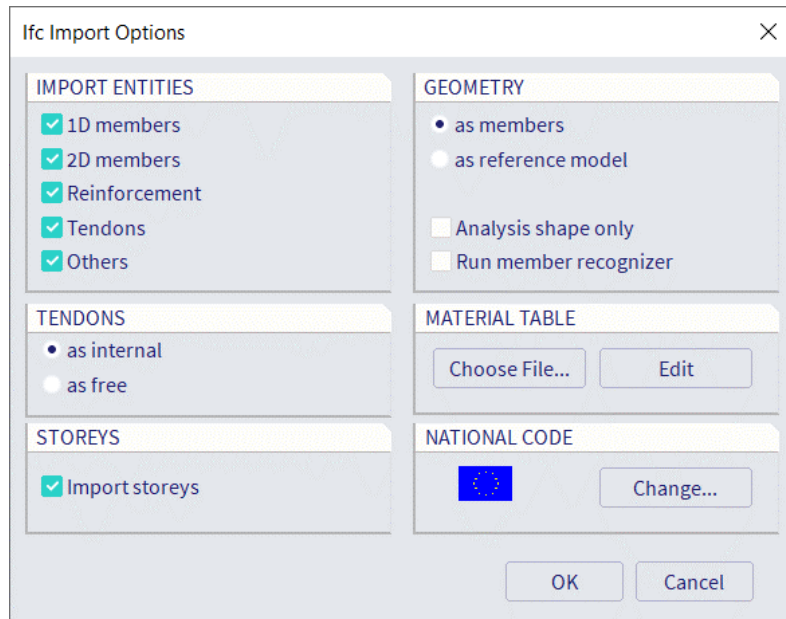

You can choose which **entities** to include or exclude from the import. **Tendons** can be imported as internal or free and storeys can be imported.

The geometry can be imported **as members**, to continue working with the model in SCIA Engineer. All supported members with SweptSolid representation are imported as SCIA Engineer native elements. Or **as reference model**, for visual purposes and to draw members over the model for instance. All members are imported as general volumes.

Without **'Analysis shape only'**, the full structural shape of the model is imported. Creation of the structural shape can take a lot of time. With this option activated, all elements are imported without clipping.

You can choose to **'Run member recognizer'** in the background, so all supported members (beams, columns, walls, and slabs) which are imported as general volumes will be attempted to be converted into native elements. After conversion a report with a result is shown.

The **National Code** needs to be chosen to start an esa-project for this model. If the material names are in accordance with this code, they will be recognized automatically. If the material names in an IFC file are not in accordance with code names it is necessary to define a **material conversion table** in the Import dialog. For the first opening of a file with defined material table there is the button 'Choose file...'. For following modifications, the button 'Edit' is available. The file has *.con file extension and it is a plain text file, for example:

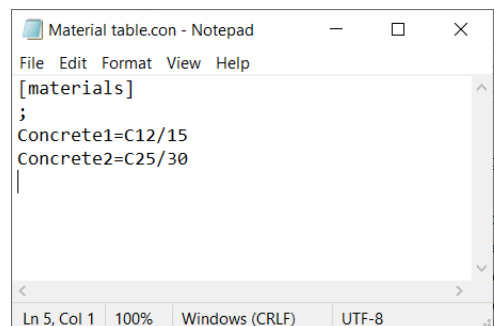

The first name is the name of the material in the IFC file and the second name is the code name of the material which is used in SCIA Engineer. It is necessary to respect all characters.

Such a file can be created by opening a new txt-file, and saving it with the .con extension (be sure to choose 'All Files (*.*)').

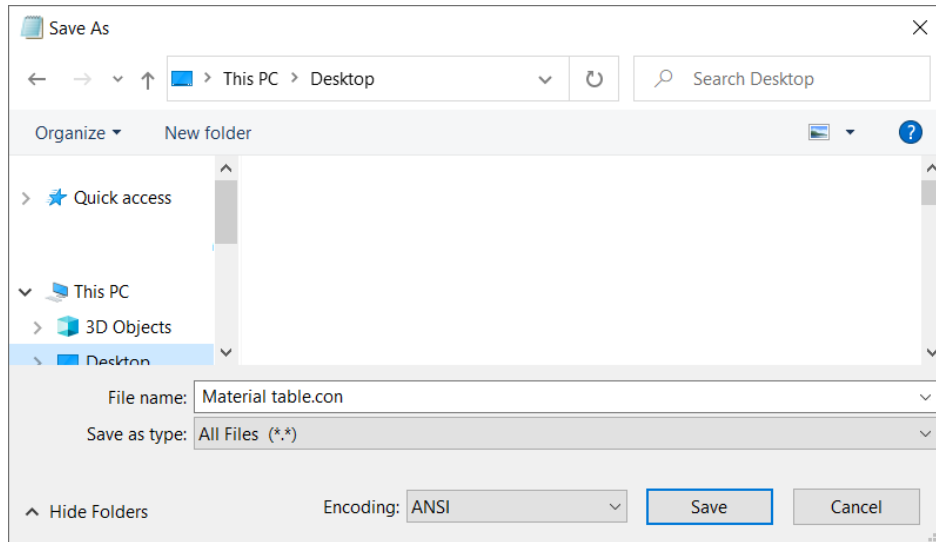

It can then be opened from the Import dialog:

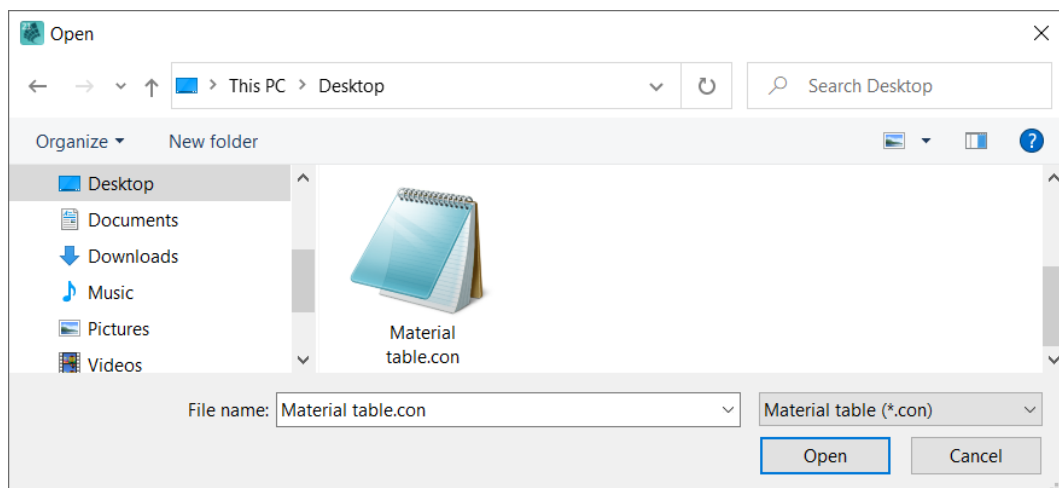

The report will be shown for import:

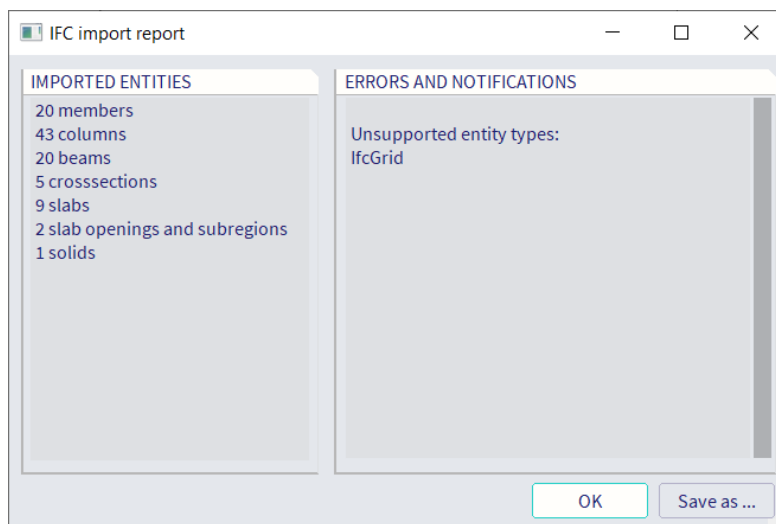

When using the update function, a dialog will be shown for the changes in the model.

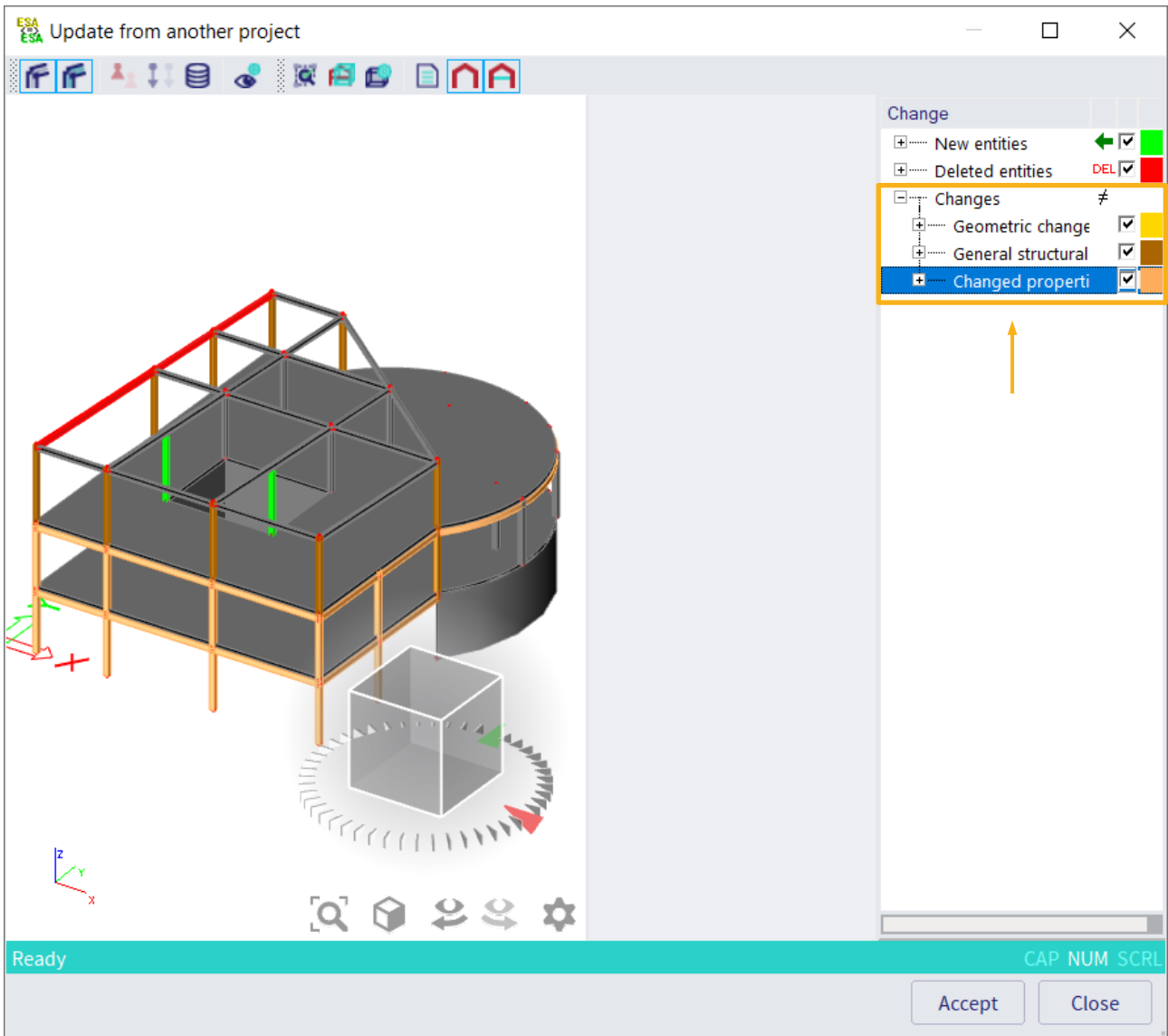

The changes need to be interpreted correctly. Especially if you used the BIM Toolbox to convert or align a previous version of the model. IFC describes the volumes of objects. This means that connecting and aligning the structure after an update is seen as a modification of the structure. If you don't want to undo these actions, you should untick these boxes.

All beam/column nodes are generated during the import. This implies that after the update action these nodes are placed in the groups "New entities" and "Deleted entities".

Click on accept to import the new entities. A message will be shown:

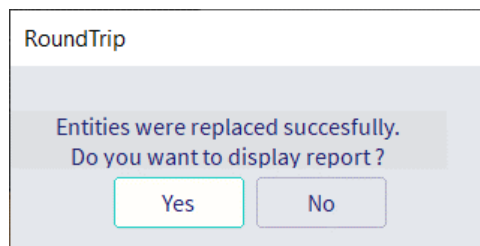

By clicking yes, you will get a full report on the updated entities.

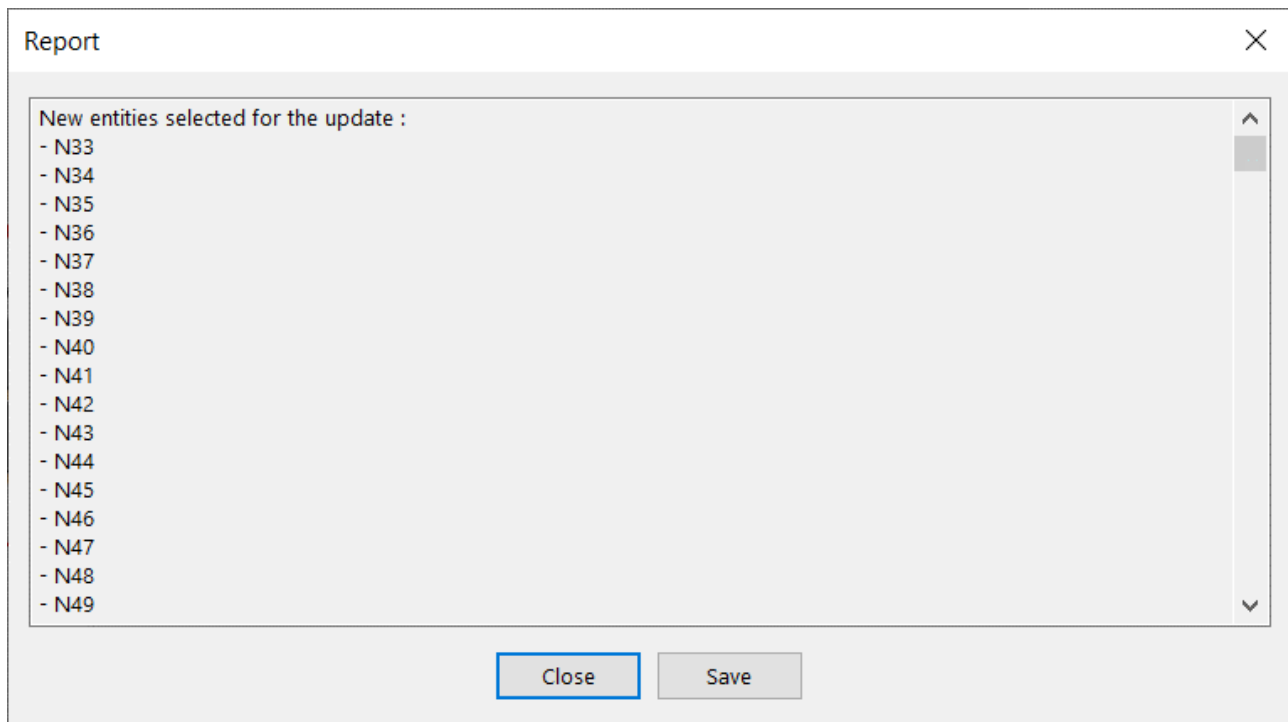

2.4.4. Import of specific elements or geometry

Openings and subregions

SCIA Engineer supports import of an IfcOpeningElement with SweptSolid representation in 1D members, with a SweptSolid representation, as a native opening.

All IfcOpeningElements defined with a SweptSolid representation in flat walls and slabs are imported correctly as native SCIA Engineer **openings or subregions**. If opening elements are defined as Brep, no opening is imported in the analysis shape, but in most cases the opening should be included in the structural model.

Concrete reinforcement

Both IfcReinforcingBar and IfcReinforcingMesh defined with AdvancedSweptSolid representation are imported into SCIA Engineer as **free bars**. If the reinforcing bar or mesh have defined mapped items, all mapped items with the same geometry and distances are imported as a free bars with correct repetition. If a reinforcing bar or mesh is defined as Brep then they are imported only as **general volumes**.

Building storeys

The current SCIA Engineer version fully supports export and import of **building storeys**. During import to SCIA Engineer, native storeys are generated using the elevations defined in the IFC file. If no elevation is defined, then storeys are generated using the placement defined in the IFC file. In case building storeys are mixed with defined and non-defined elevations the result may be unexpected.

Line grids

Import of **line grids** is not supported.

2.5. BIM Toolbox

The BIM Toolbox offers some functionalities to handle imported models, especially IFC's.

Sometimes, after importing a model from another application a structure consists of unconnected **general solids**. These can often be converted to SCIA native members using the BIM Toolbox.

On the other hand, a structure can be aligned using the BIM Toolbox. As explained in chapter 1, an IFC uses the structural model representation. When such a model is imported, the generated analytical model is often not connecting the members in the right nodes. **Aligning the structure** fixes this issue.

The BIM Toolbox and its commands can be found in the 'Tools' menu.

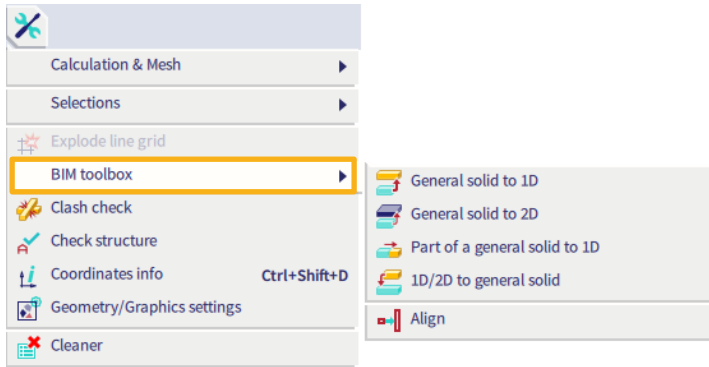

Note that there are a lot of settings to consider in the 'Align' functionality and this can take up a lot of time or become very complicated for large models. The **SCIA Autoconverter** was developed to overcome these difficulties and automate this process.

2.5.1. Convert

Via the BIM Toolbox you can convert volumetric elements (i.e., solids) into native SCIA Engineer elements (beam, column, plate, wall). This is a necessary step in order to be able to calculate the imported project because you cannot generate a mesh (thus calculating) on solids in SCIA Engineer.

This can be easily done by selecting the elements and using the proper command for the correct conversion type (1D/2D). An automatic recognition algorithm detects the associated cross-section during the conversion of solids to 1D-members. The same applies for 2D-members in which the associated thickness is detected and assigned to it.

Below an example of imported solid elements (left side). After conversion (right side) you will obtain native SCIA Engineer 1D-members with their associated cross-section.

Imported solid elements

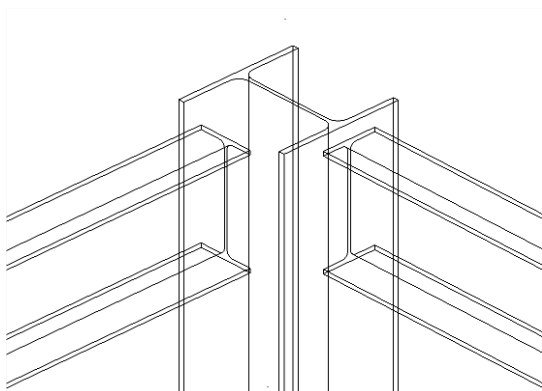

Converted to native SCIA Engineer elements

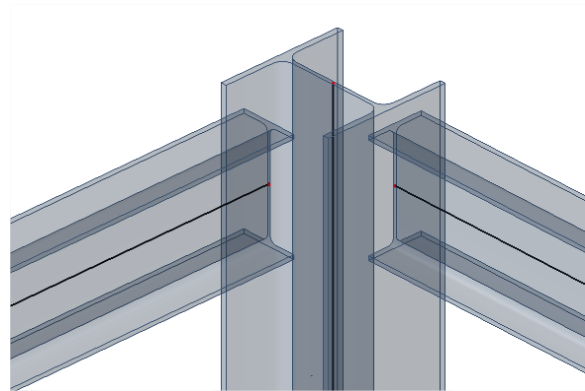

2.5.2. Align

A model consisting of solids are interconnected based on their volumes. But in analysis software like SCIA Engineer it is necessary to have a connection in the member system line for 1D-members or the member system plane for 2D-members.

Below an example of not aligned & not connected 1D-members (left side). Via the align functionality in the BIM toolbox a connection in 1 node (right side) can be obtained.

Not aligned & not connected 1D members

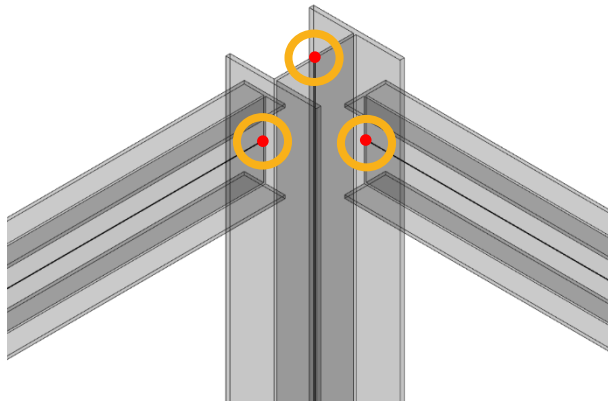

Aligned & connected 1D members

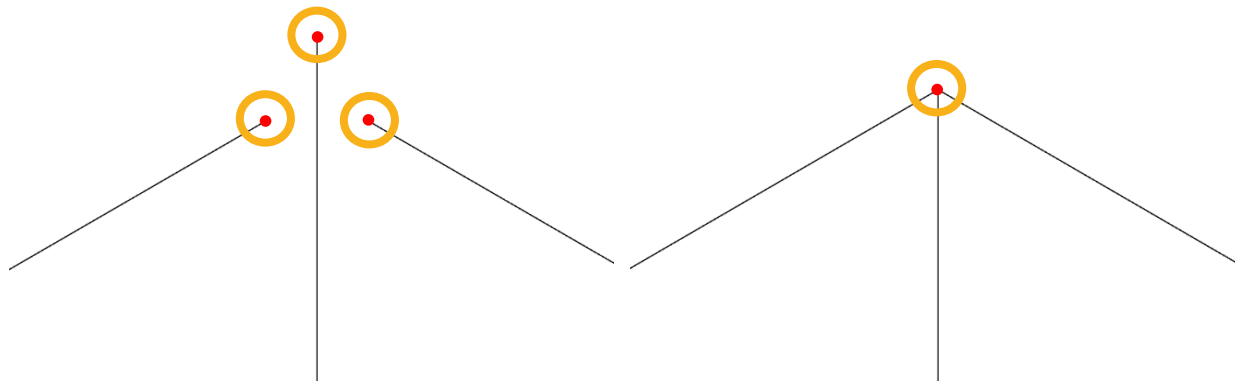
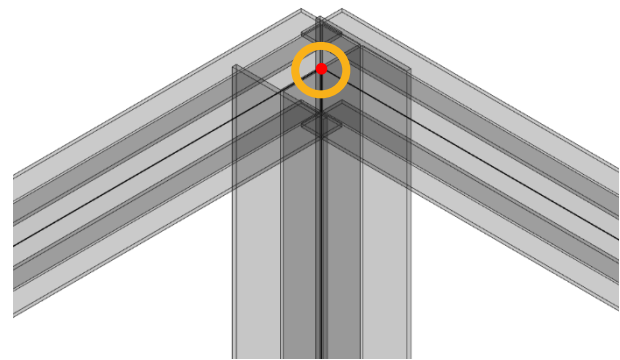

Structural elements can be aligned by moving the nodes of the 1D-/2D-members or the entire 1D-/2D-member to the master planes. This is done with the 'Align' command in the BIM Toolbox.

Settings

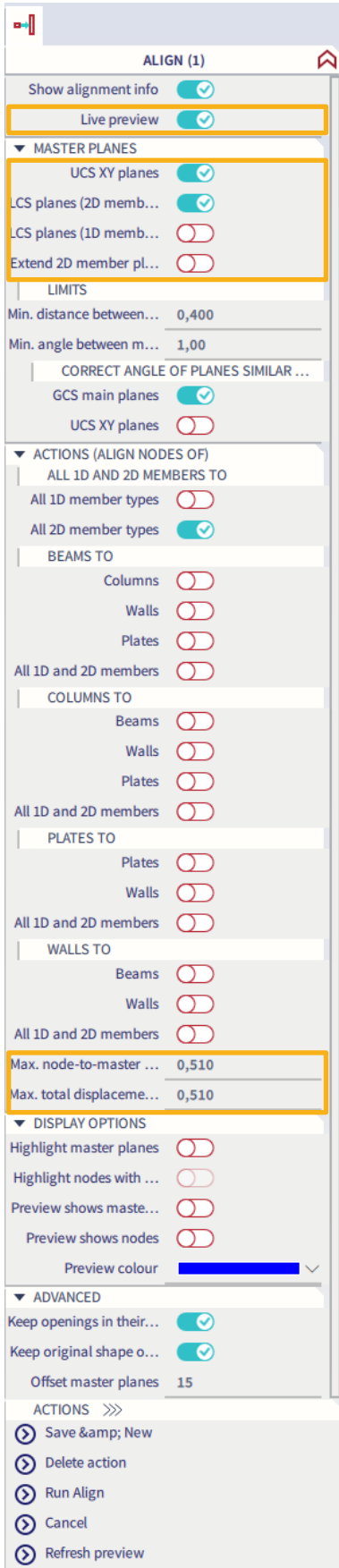

The marked options are the properties that are usually modified during an alignment action.

Alignment information can be shown in a separate window.

Also, before executing the alignment, you can see a preview appear in the model when activating “**Live Preview**”.

Master planes can be chosen to which you can align the structural elements.

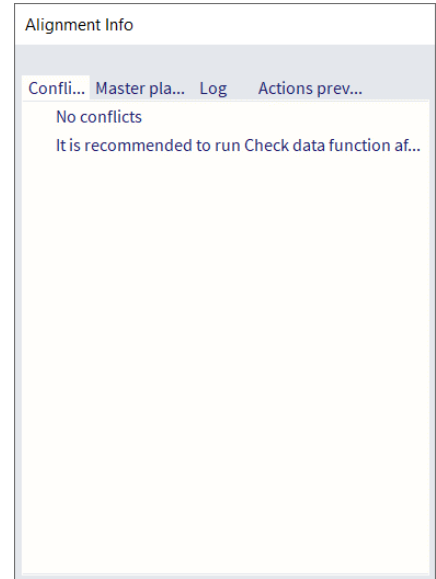

The **alignment of nodes** from one structural type (beam, column, wall, plate) to another structural type can be specified

Maximum displacement settings can be specified. This is an important setting because if the node to master plane distance is higher than this value no alignment can occur for that node.

Display options can be modified

Advanced settings.

Workflow

The workflow to follow to align a structure is explained in the example below. Each structure will require specific settings. You can start the align function for either all entities or a selection of entities.

For this model, the following properties are checked: Live preview, all master planes.

When clicking on the current action tick box, you can see the preview of the alignment appear in the form of blue lines.

This gives you feedback of the chosen alignment settings before running the alignment.

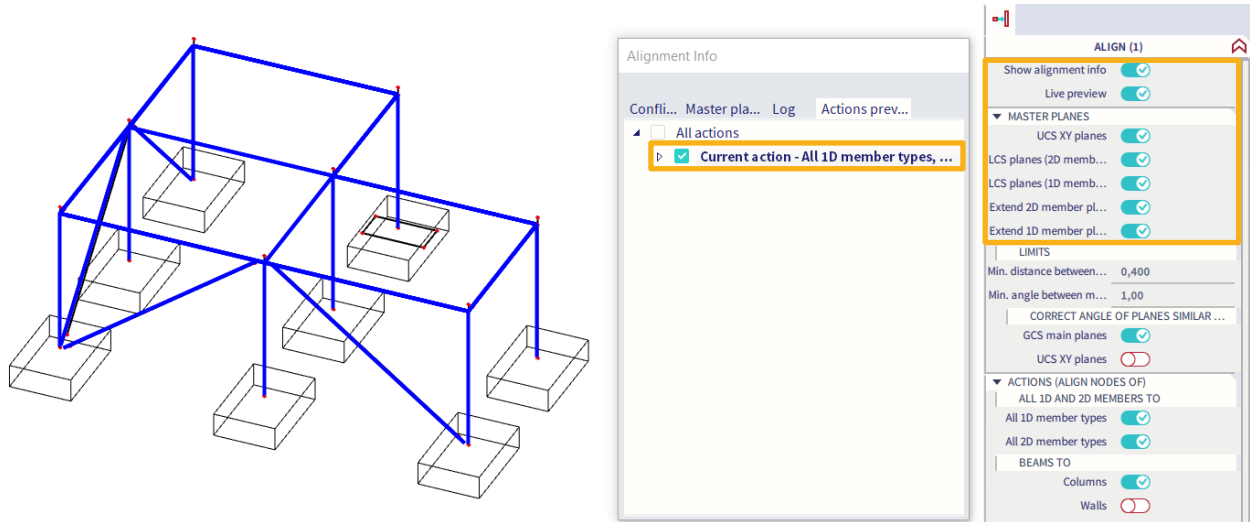

The master planes that are going to be used can be visualized by going to the tab 'Master planes'.

If you click on planes you can see the master planes appear in the model.

To execute an alignment in an orthogonal matter (horizontal and/or vertical), the diagonal master planes shouldn't be used, so they can be ticked off.

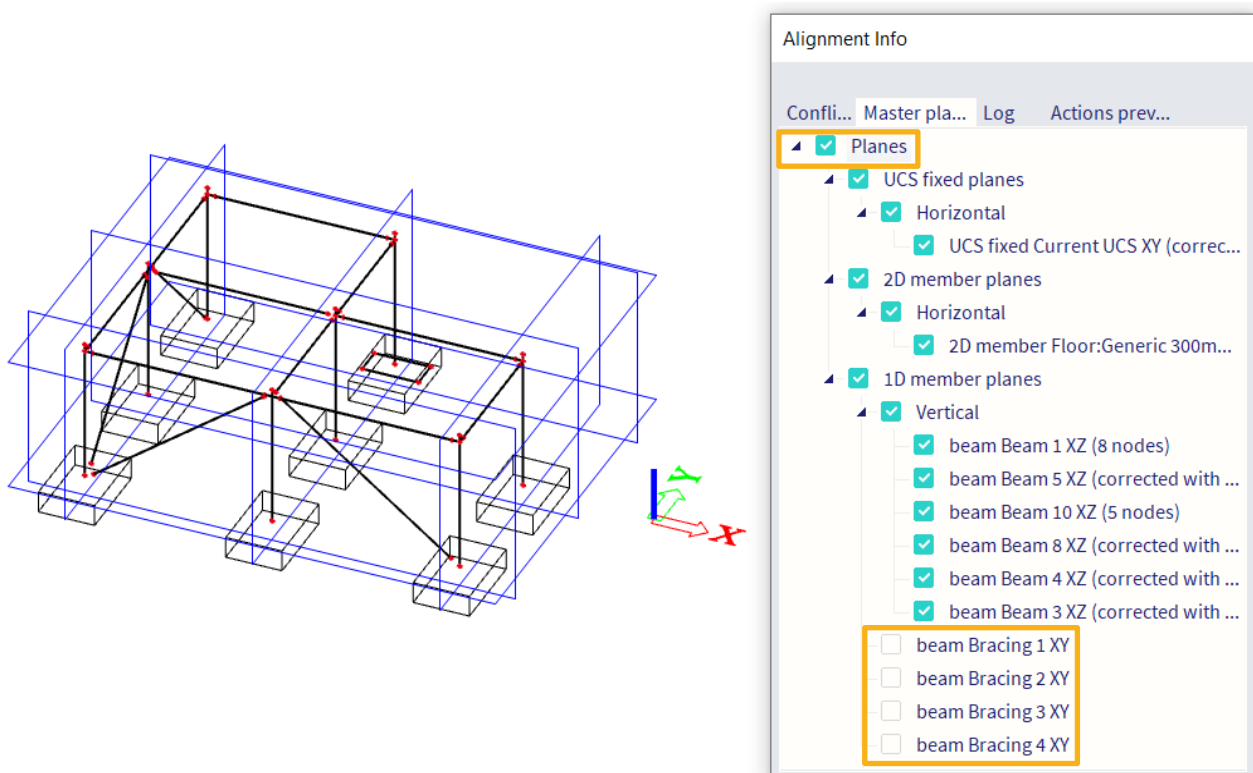

To make sure the bracings are connected to the same nodes as the column and beam intersections, you can increase the maximum displacement settings. The correct alignment is now shown for the 'actions'.

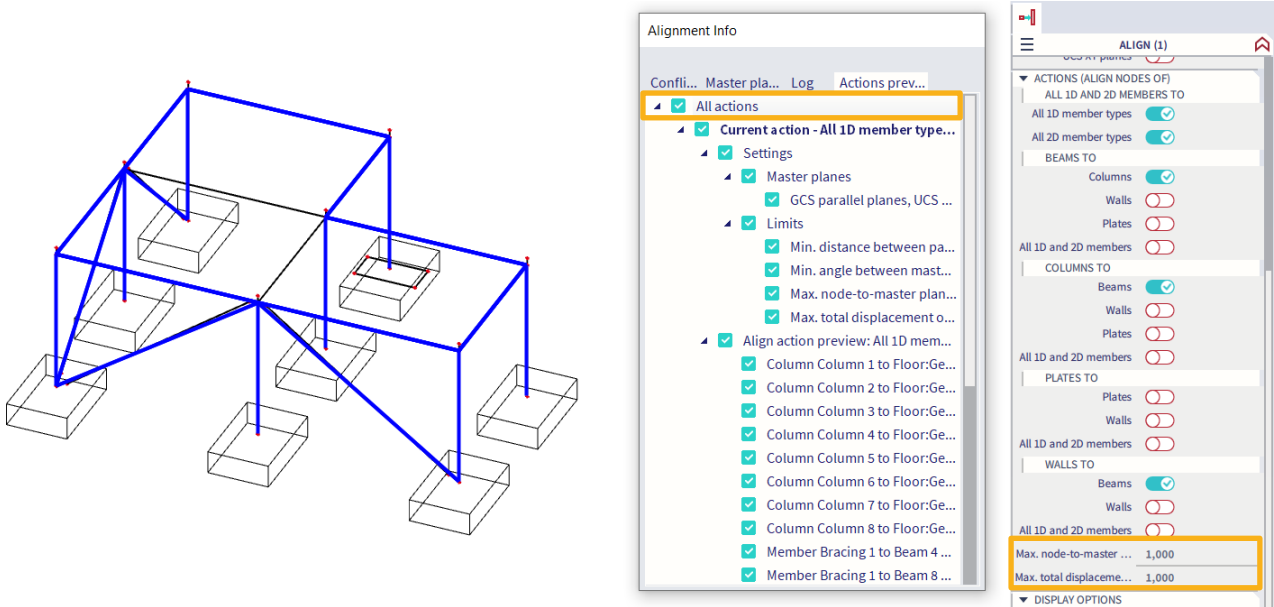

Make sure the 'All actions' box is ticked before executing 'Run Align' at the bottom of the properties panel.

Now the entire structure is aligned as can be seen in the following pictures.

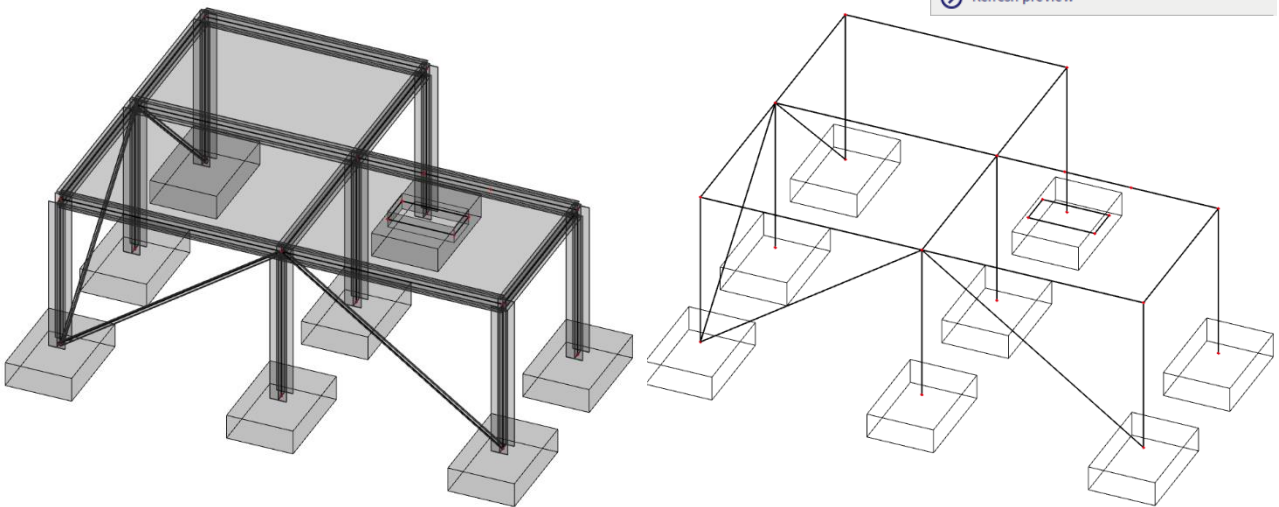
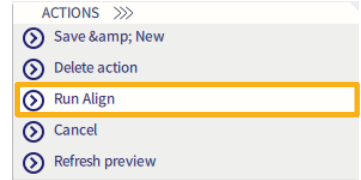

The structure has been aligned by moving nodes, which means there can still be duplicate nodes present. Therefore, it's still necessary to check the structure data. The members also need to be connected using the connect members/nodes command. They can be found in the following menu's:

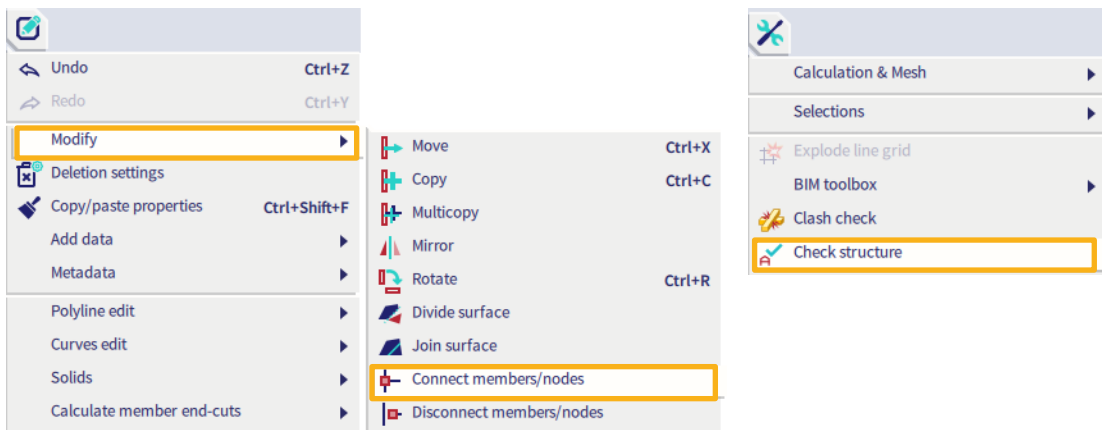

The standard settings are usually okay to proceed with. In this case, the process went as shown in the pictures:

Check of structure data

CHECK OF NODES

Search nodes 0%

Search duplicate nodes Ignore parameters 0%

CHECK OF MEMBERS

Check members

Search null members 0% Null members: 0 Delete null members

Search duplicate members 0% Duplicate: 0 Delete duplicate members

Invalid parts: 0 Delete invalid parts

CHECK OF DATA REFERENCES

Check data references Memory efficient method

Fast method

CHECK OF ADDITIONAL DATA

Check additional data position 0% Invalid position: 0 Correct position

Check free load distribution points 0% Invalid loads: 0

CHECK OF STEEL CONNECTIONS

Check steel connections 0% Invalid: 0 Delete invalid connections

Check load panels Check cross-links

Check additional data Check duplicity of names **Check** Cancel

Result of check of nodes

These problems have been found with nodes:

Members with undefined	0	<input type="checkbox"/> Correct it
Free nodes	18	<input checked="" type="checkbox"/> Correct it
Duplicate nodes:	0	
Nodes not in slab:	0	
Incorrect coord.	0	

Do you want to correct it?

OK Cancel

Data check report

 18 nodes have been deleted

OK

Setup for connection of structural entities

Align structural entities to planes (moving ...) Align

Geometrical tolerance

Min. distance of two nodes, node to curve [m] 0,000

Max. distance of node to 2D member plane [m] 0,000

Connect (generate linked nodes, intersecti...

Connect

Autorestore buckling group when reconnecting

Connect 1D members as ribs

Connect 1D members with rigid links

Max. length of rigid link [m] 0,100

Create new linked node for master node

Check structure data

Check (merge duplicate nodes, erase invalid entities)

OK Cancel

SCIA Engineer

 During the calculation of intersections : 8 new intersections have been generated

OK

2.6. Exchange with BIMPLUS or BIMCloud



The **BIMPLUS platform** facilitates the workflow of a BIM project, providing you with a wide range of features for collaboration. This platform operates in the cloud (i.e., a BIM server). BIMPLUS is a service provided by Allplan. It is mainly developed for Allplan but users of different software (e.g., Revit) should be able to use it also because the IFC-format is a vendor neutral format.

Regardless of the tool you use, you should always check the IFC files you created yourself or you received from partners in two respects:

- Check that the geometry of the building is correct and that the components are positioned correctly. In addition, make sure that the model is complete.
- Check that the attribute sets (Psets) of the objects include all necessary parameters, attributes, and pieces of information.

Compared with any IFC viewer, the open BIMPLUS platform provides you with many more features and options. You can use the platform not only to **check** data but also to **collaborate and communicate** with your partners throughout the project.



You can upload multiple IFC models to BIMPLUS and assign tasks and communicate on this platform. The communication between all the partners happens via BCF (Building Collaboration Format). Whereas IFC as a neutral format is used to exchange models and building information in a BIM project, **BCF** is the format partners and project participants use to communicate.

Models can be exchanged between SCIA Engineer and BIMPLUS through the import/export functions:

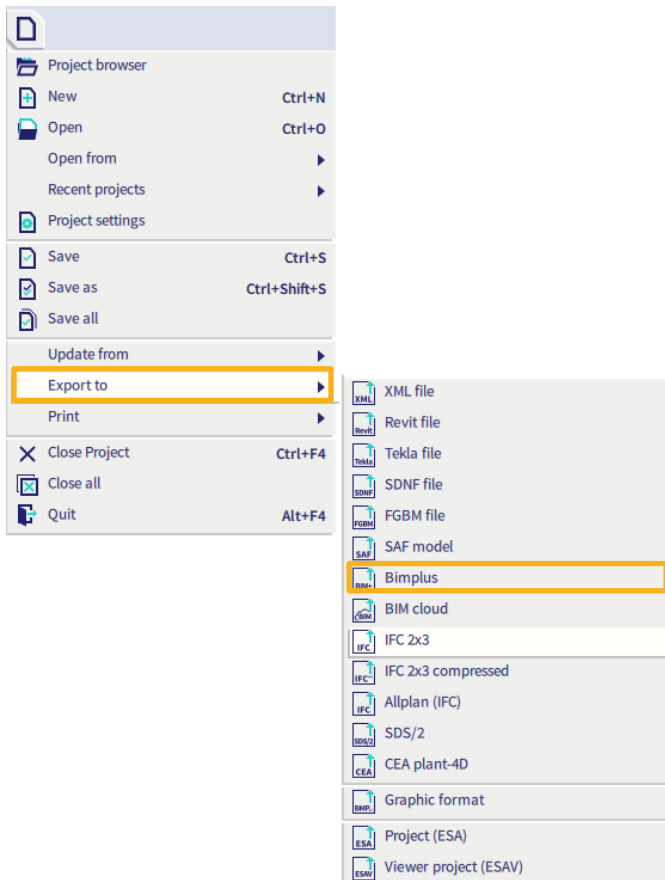

You will be asked to log in with your BIMPLUS Account:

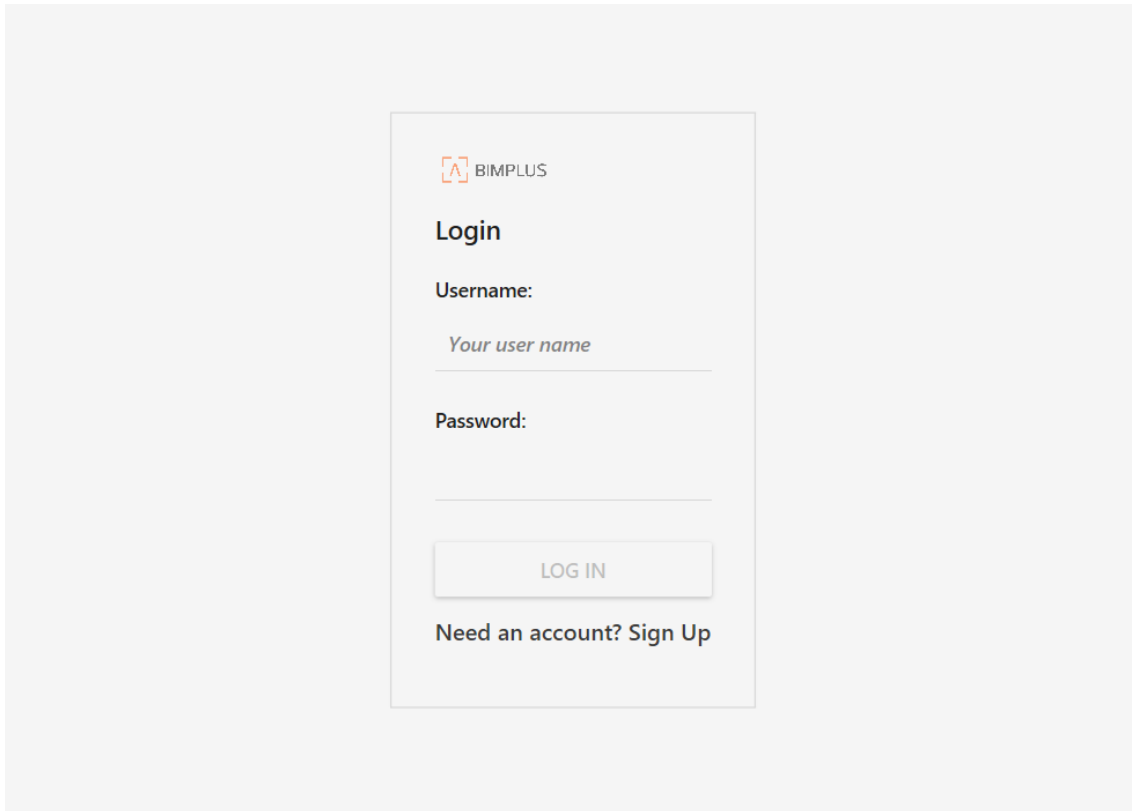

The image shows a login form for BIMPLUS. At the top left is the BIMPLUS logo. Below it is the heading "Login". There are two input fields: "Username:" with the placeholder text "Your user name" and "Password:". Below the password field is a "LOG IN" button. At the bottom of the form, there is a link that says "Need an account? Sign Up".

Choose a team, choose or create a project, model and revision, and send it to BIMPLUS using the 'Update' button.

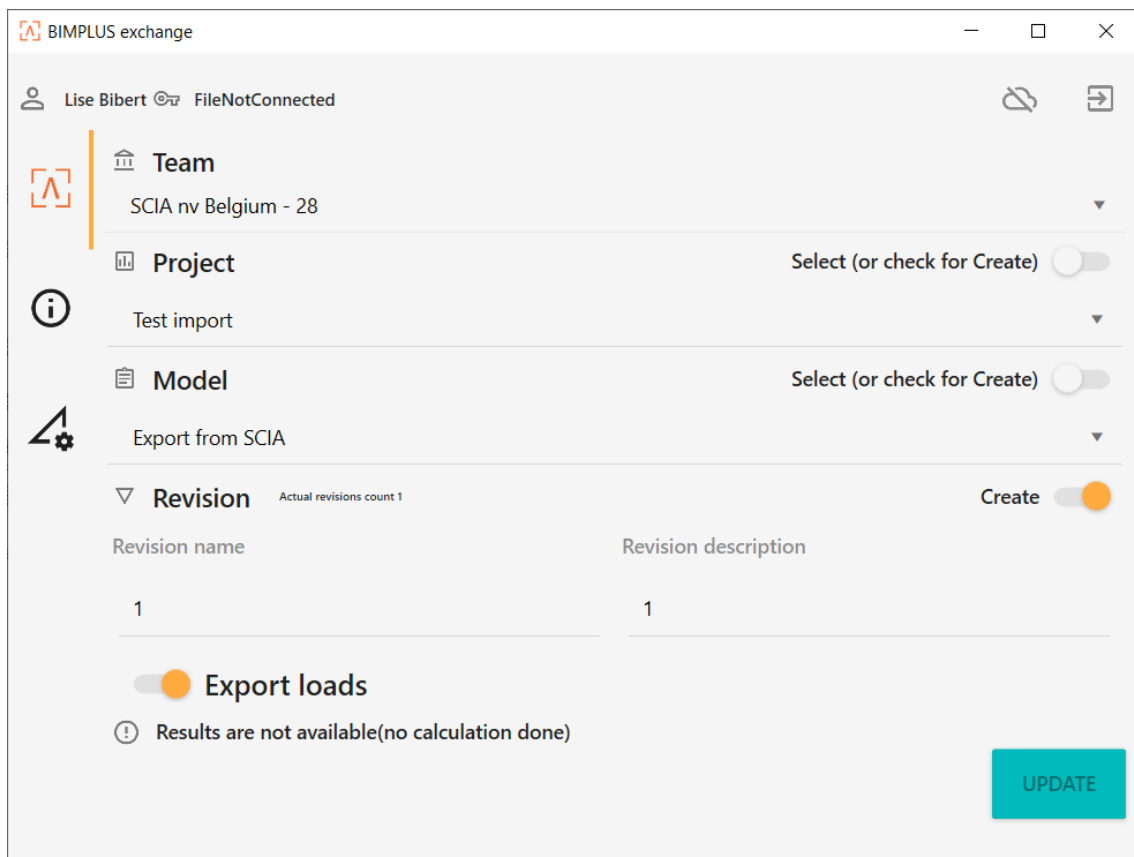

The image shows the BIMPLUS exchange interface. The window title is "BIMPLUS exchange". The user is logged in as "Lise Bibert" with the status "FileNotConnected". The interface is organized into sections:

- Team:** SCIA nv Belgium - 28
- Project:** Test import. A toggle switch for "Select (or check for Create)" is currently off.
- Model:** Export from SCIA. A toggle switch for "Select (or check for Create)" is currently off.
- Revision:** Actual revisions count 1. A "Create" toggle switch is currently on.

Below the revision section, there is a table with two columns: "Revision name" and "Revision description". Both columns contain the number "1".

At the bottom of the interface, there is a toggle switch for "Export loads" which is currently on. Below it, a warning icon and text state: "Results are not available(no calculation done)". A large teal "UPDATE" button is located in the bottom right corner.

The model will now be exported and the progress is shown.

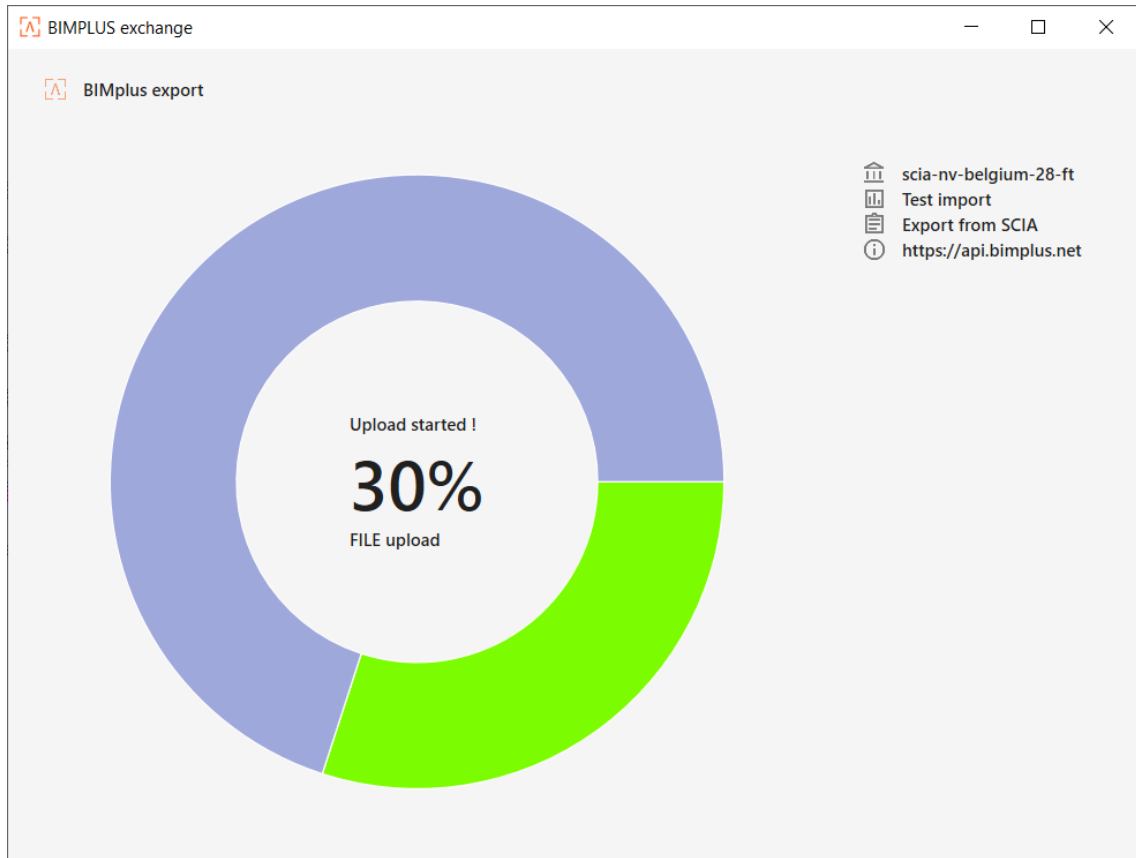

A report shows if the transfer was successful.

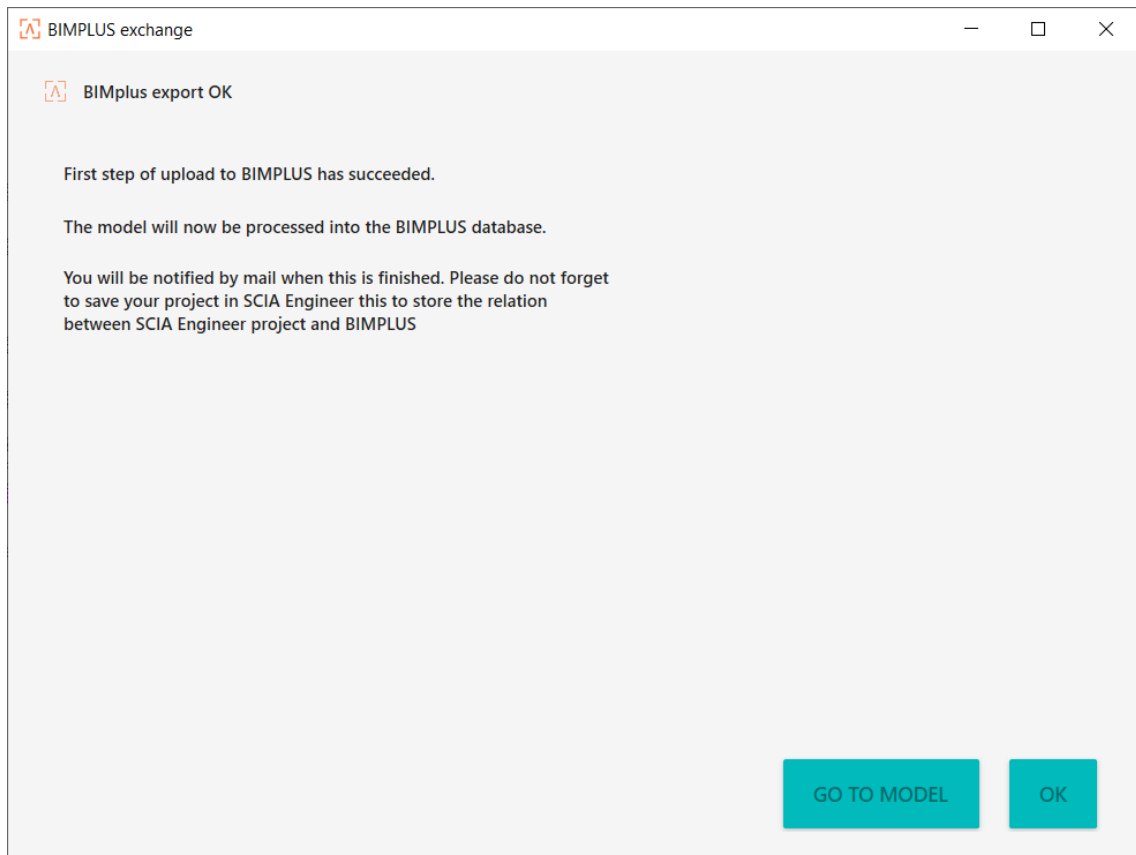

The process of importing/updating from BIMPLUS is very similar and can be done from the menu:

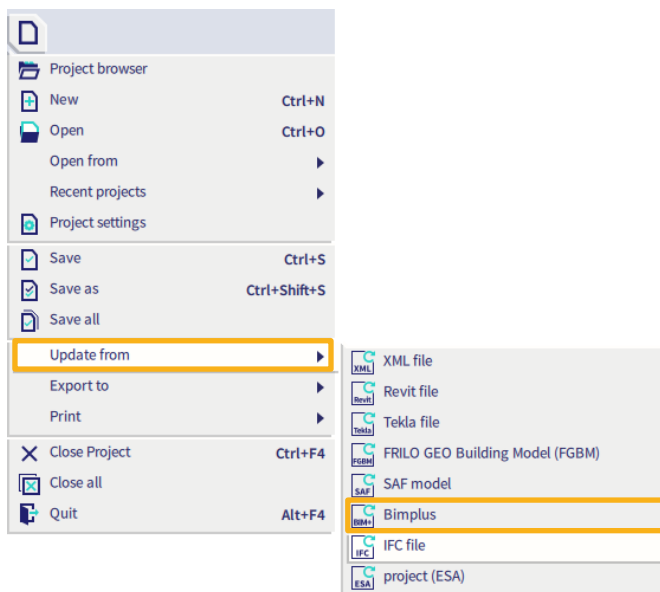
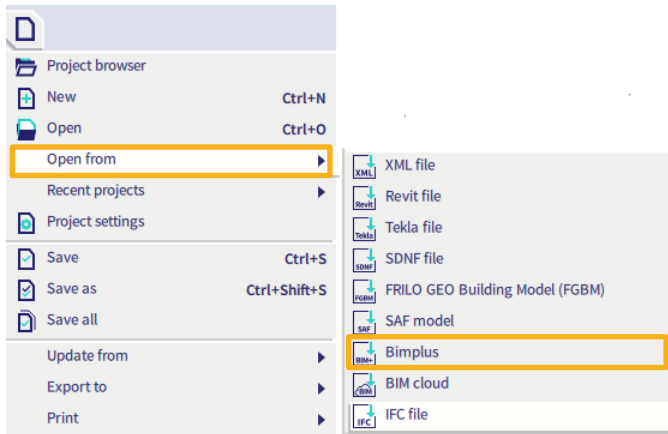

You will be asked to select a team, project, model and revision:

This screenshot shows a dialog box for selecting a team, project, model, and revision. The user is identified as 'Lise Bibert'. The dialog has four sections, each with a dropdown menu:

- Team**: Select team ! (Select team...)
- Project**: Select project...
- Model**: Select model...
- Revision**: Select revision...

At the bottom of the dialog, there are two buttons: 'CLOSE' (highlighted in teal) and 'DOWNLOAD'.

The download process is shown:

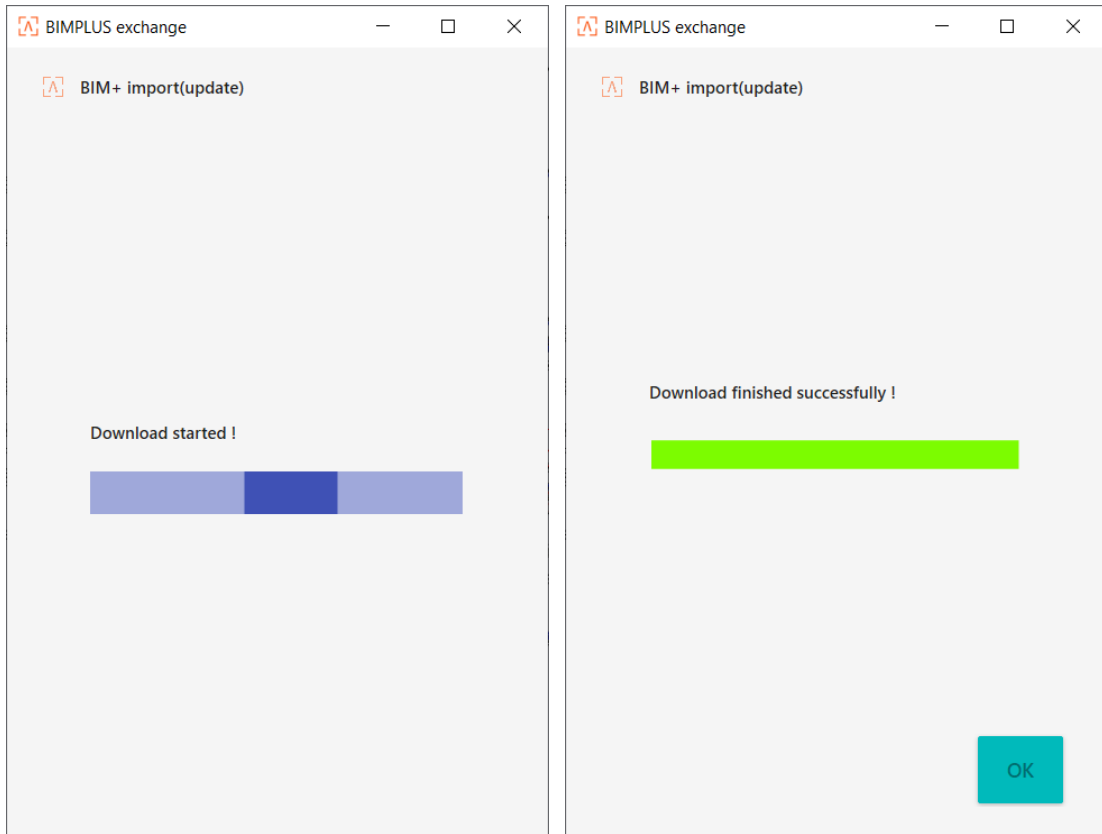

A window can be shown for SAF exchange, just click on 'OK' and the model will be opened in SCIA Engineer.

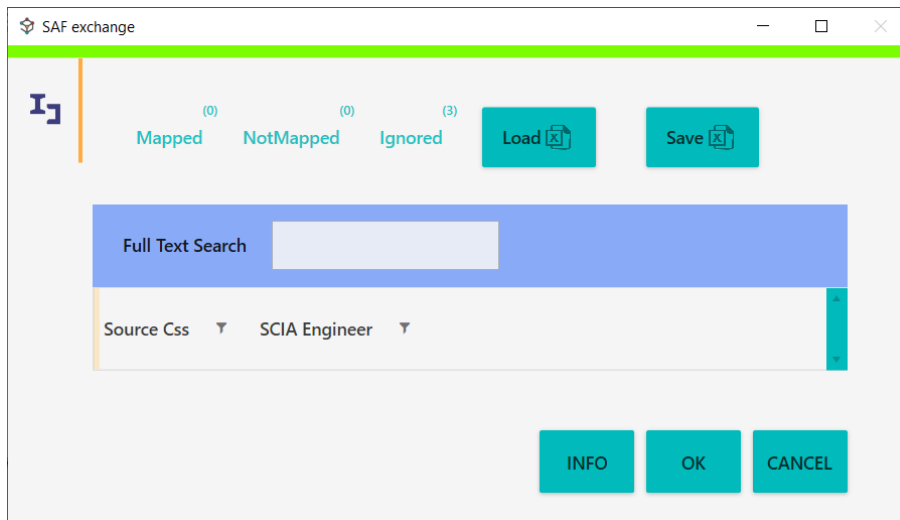

Similarly to BIMPLUS, exchange with the collaboration



Chapter 3: Exchange via the Revit-link



The CADs Revit SCIA Engineer link facilitates the bi-directional exchange of members, loads and supports between Revit and SCIA Engineer and in doing so plays a vital role in the overall Building Information Modelling (BIM) process. A structure modelled in Revit can be transferred to SCIA Engineer for structural analysis and design using CADs Revit SCIA Engineer link. When the structural analysis and design has been completed in SCIA Engineer, the updated model can be sent back to Revit. The modelling - analysis - design process requires numerous iterations to arrive at the final design. CADs Revit SCIA Engineer link will save time by avoiding duplication and reducing errors.

! Note: Make sure you read the introduction and understand the concept of structural and analytical models.

3.1. Installation of the Revit-link

There are two ways to install the Revit plugin. It can be done from the setup of SCIA Engineer, or the plugin can be installed from a separate setup.

It's possible but not necessary to have SCIA installed on the same computer as Revit and the Revit plugin. This means that employees that use Revit but don't work with SCIA, can still install the plugin and provide exported files to the Engineers that use SCIA Engineer, or import files coming from SCIA.

The use of these files in SCIA, and exporting from SCIA to Revit, is then possible as long as the needed modules for Revit Exchange are available in the SCIA license.

The plugin can be installed from the SCIA Engineer Setup in the following way. First, download the SCIA Engineer setup from the website:

<https://www.scia.net/en/support/downloads>

This is recommended over modifying the existing installation directly, because all the necessary files and relations are directly available in the setup. Otherwise, a message could appear stating that some files cannot be found.

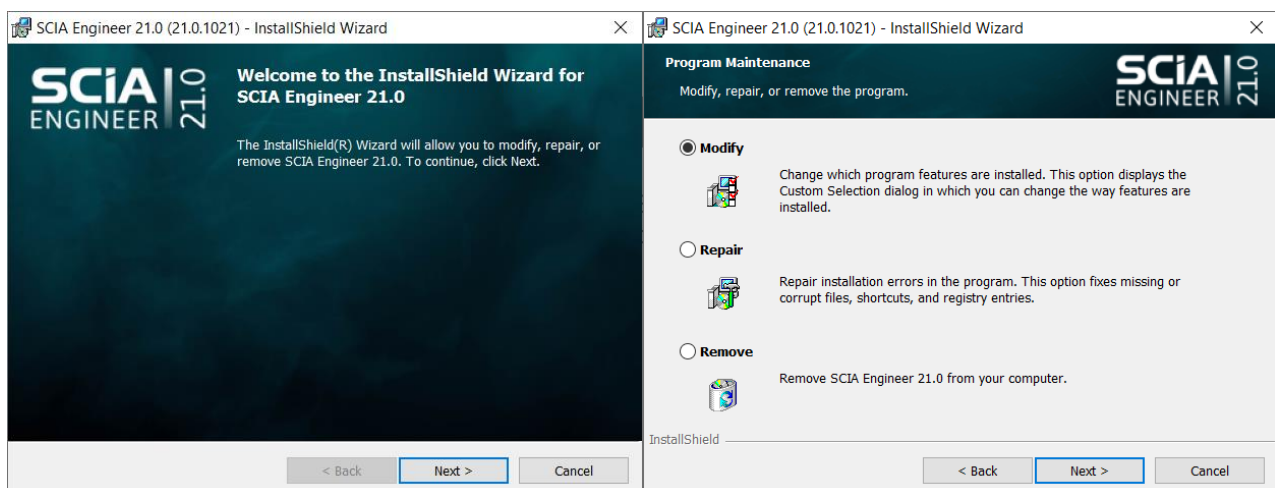

Choose to 'Modify' the installation, click 'Next >' and select the Revit plug-in under Add-ons. Select 'This feature will be installed on local hard drive'.

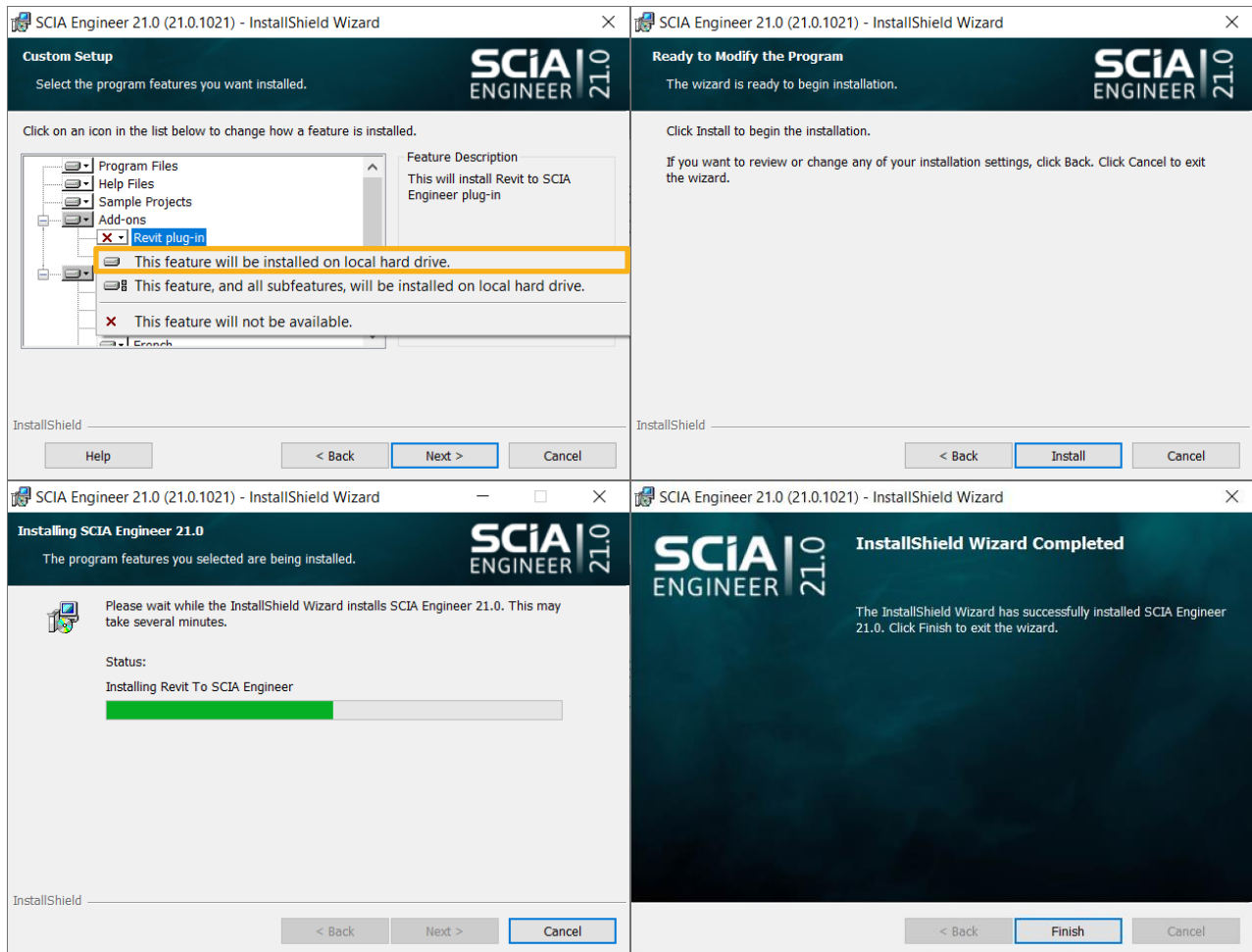

The latest version of the plugin and its separate setup should be available on the SCIA Website:

<https://www.scia.net/en/support/downloads/plugin-revit-structure-scia-engineer>

And on the CADs website:

<https://cads.co.uk/support-and-learning/product-downloads-updates/>

The installation is straightforward and is shown in the images below. Recent versions of the plugin support two versions of Revit at the same time. Older ones were installed only for one version of Revit, so if there were multiple versions of Revit installed on your computer, it would automatically take the 'default' version.

Note: The latest plugin supports almost all previous versions of Revit, so it's not necessary to download a specific older version of the plugin.

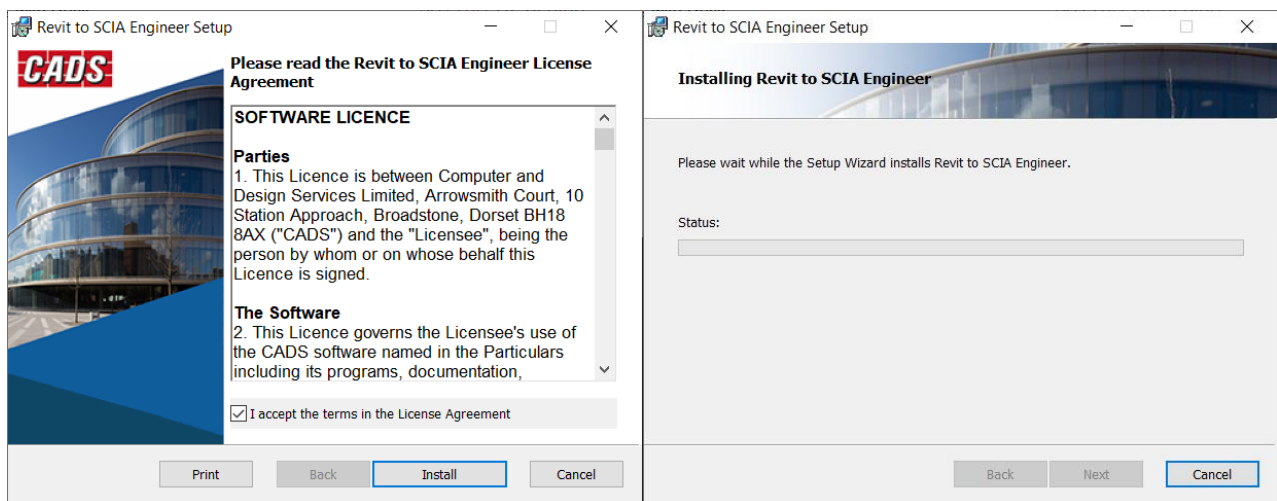

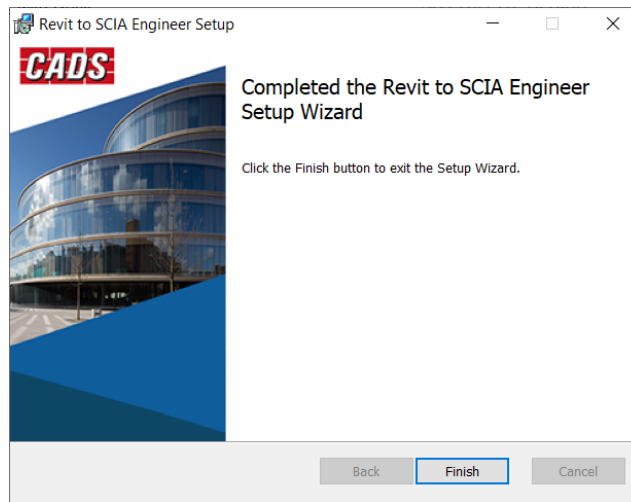

Once the installation is complete, the following message should appear upon opening Revit:

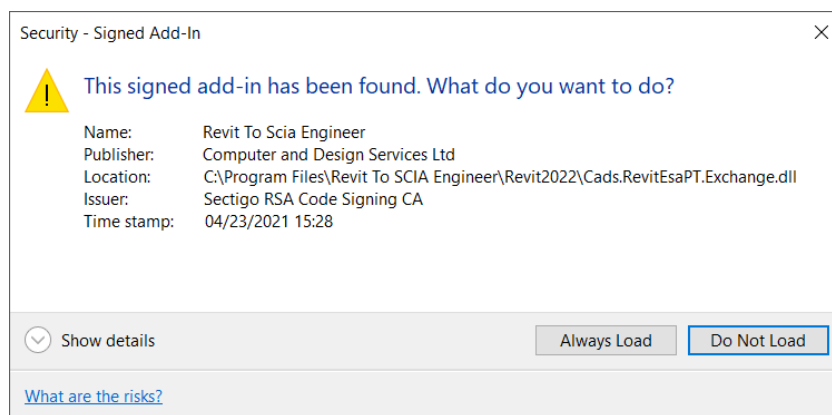

The recommendation is to 'Always load' so the message will not appear again.

The following toolbar will now be available under the tab 'CADs':

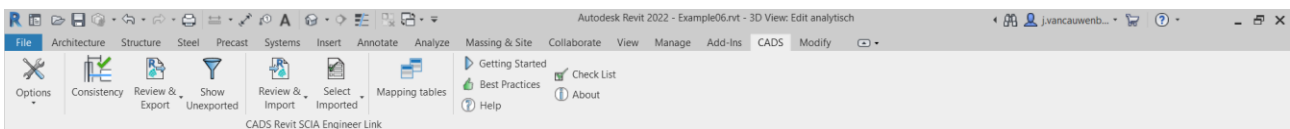

3.2. Overview

Here's an overview of all available options:

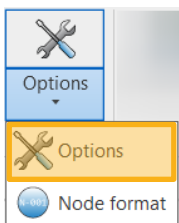

National Code:
Choose the code according to which the model is built (profiles, materials...).

Mode of export:
'Direct exchange'
The model is sent directly from or to SCIA. This is only possible when SCIA is installed and open on this computer. The correct SCIA Engineer version needs to be specified in the next option and a valid Revit Exchange module must be part of the SCIA license.

Export to SCIA Engineer:
'Direct exchange' as Mode of export:
The model open in Revit will be transferred to SCIA.
'File exchange' as Mode of export:
The Revit model will be exported as a r2s-file. You will get the option to choose a save location.

Import from SCIA Engineer:
'Direct exchange' as Mode of export:
The model open in SCIA will be transferred to Revit.
'File exchange' as Mode of export:
You will get the option to choose a s2r-file to open in Revit.

'File exchange'
An exchange file is exported and saved or imported. This is possible with or without installation of SCIA on this computer.

SCIA Engineer version:
Browse to the installation path of SCIA Engineer and choose the version you wish to make the exchange to/from. This is only necessary for the direct exchange method.

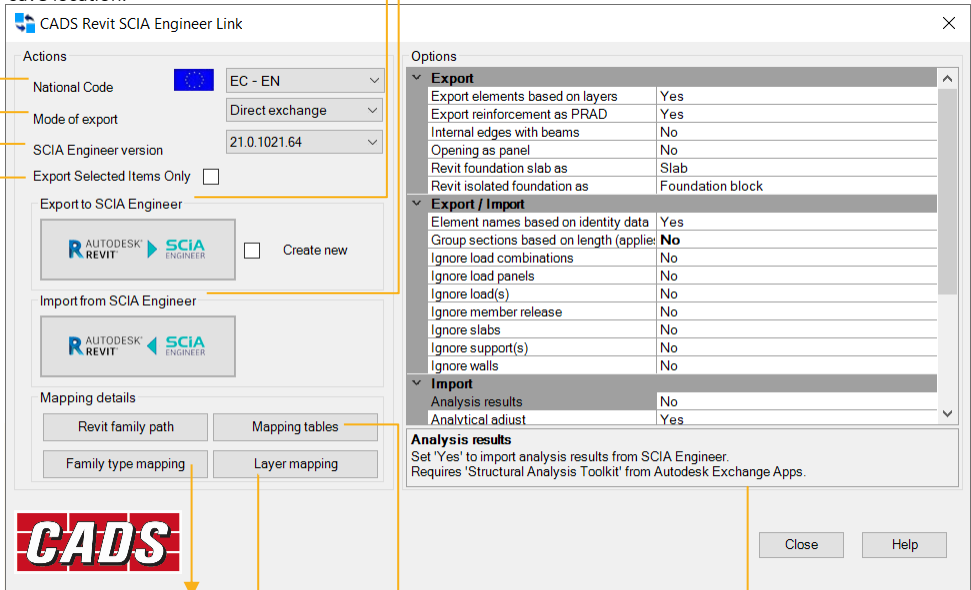

Export selected items only:
Check this box if you wish to only export the current selection instead of the entire model.

Revit family path:
Choose or add families that are used to map the Revit-model to SCIA cross-sections.

Family type mapping:
View the automated family mapping according to the chosen National Code.

Layer mapping:
Table for mapping the Revit layers to the SCIA layers.

Mapping tables:
Tables for mapping the Revit materials, cross sections, and other parameters to the corresponding SCIA properties.

Options:
Specify which objects or results should be exported/imported.

All possibilities in the toolbar are:

Consistency check:
It is recommended to execute a consistency check before exchanging a model from Revit Structure to SCIA Engineer in order to be sure that the analytical model is correctly generated and connected.
It is recommended to apply the following setting in Revit Structure:
Go to manage > Structural Settings > Go to the tab: Analytical Model Settings > Tick on 'Member Supports' and 'Analytical/Physical Model Consistency'.

Select imported:
A selection can be made based on the following criteria:

- All changes
- New elements
- Geometry
- Section size
- Material type

Documentation:
If you are searching for extra documentation or help, then these options can be of great help to you.

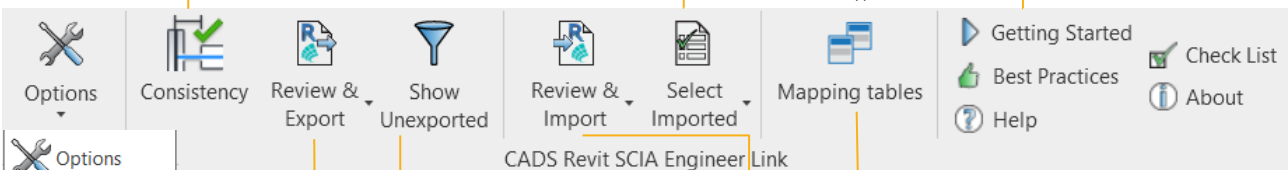

Node format:
You can define the node format via Options > Node Format. This will be used for the naming of the nodes in SCIA Engineer.

Show Unexported:
The elements that couldn't be exported can be localized and highlighted in the model via Show Unexported.

Review & Export/Import:
With the review functionality a model comparison can be made between the current model in Revit Structure and the to be imported/exported model. The user has then the possibility to select which new/modified/deleted elements should be exchanged or not.

Mapping tables:
The user mapping table that can be found in the 'Options', can be accessed here, and can be stored or loaded to/from an XML file.

Note that the **direct exchange** method is (due to technical limitations) only linked to one SCIA Engineer interface for SCIA 21 and SCIA 22. This is the old interface, so SCIA Engineer XX.X Legacy. Starting from SCIA 24, the plugin is linked to the new interface.

3.3. Exchange from Revit to SCIA

3.3.1. Generating the analytical model in Revit

As referred to in chapter 1, modelling a structure in Revit concerns the structural model. For exchange with SCIA Engineer, we are interested in the **analytical model**. This representation is automatically generated in Revit and can be visualised.

An important note is that only **analytical elements** can be exported from Revit to SCIA. If the model contains any architectural entities, then they won't be exported. This also applies for elements for which 'Enable analytical model' has not been ticked on. Some versions of Revit or some Revit families don't allow/have this option, so be careful about that.

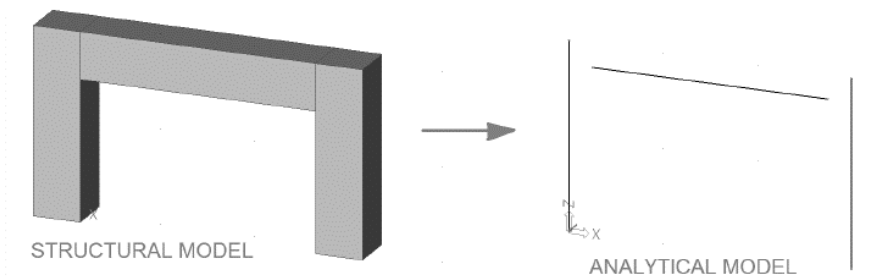

It's very important that the analytical model is correctly constructed in Revit. This depends on the modelling of the structural model. As you can see in the above figure, a good-looking structural model can contain a very bad underlying analytical model. The beam is clearly not connected to the columns in the analytical model.

These issues can be prevented in Revit Structure by maintaining the analytical model or you can correct these issues to a certain extent later on in SCIA Engineer via the BIM Toolbox.

Shown below are two examples of structural/analytical elements that can be exported to SCIA Engineer when the correct settings are used:

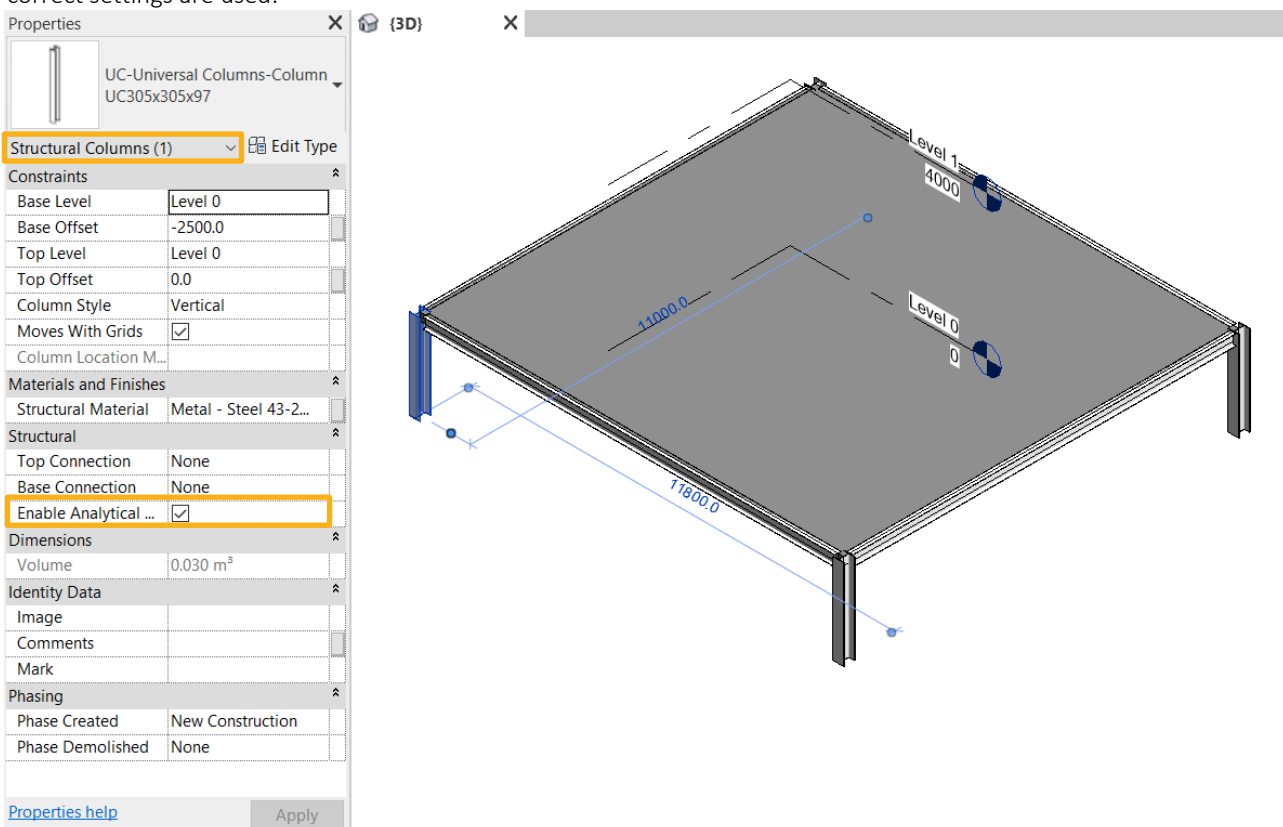

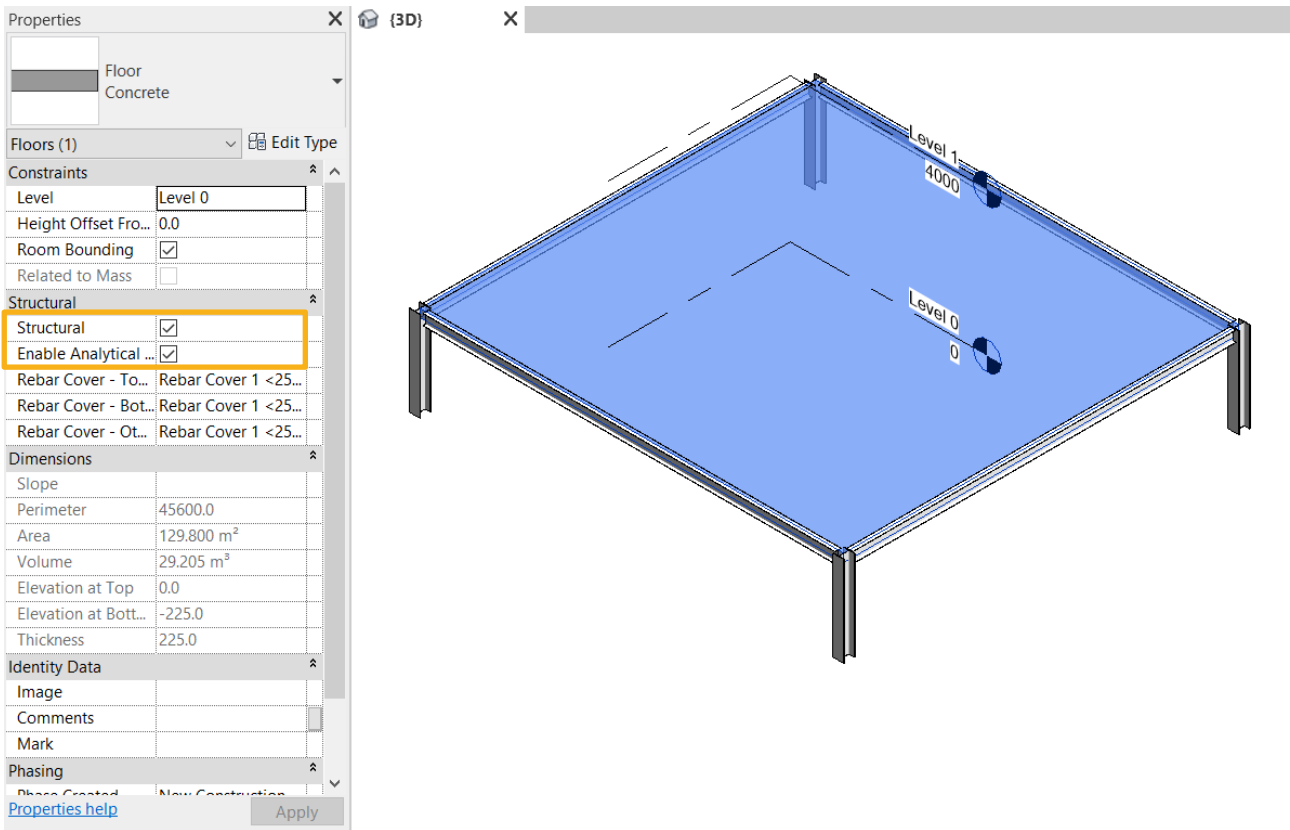

The analytical model can be shown using the visibility settings (hotkey 'vv'), by not showing the general model categories but showing the analytical model categories instead.

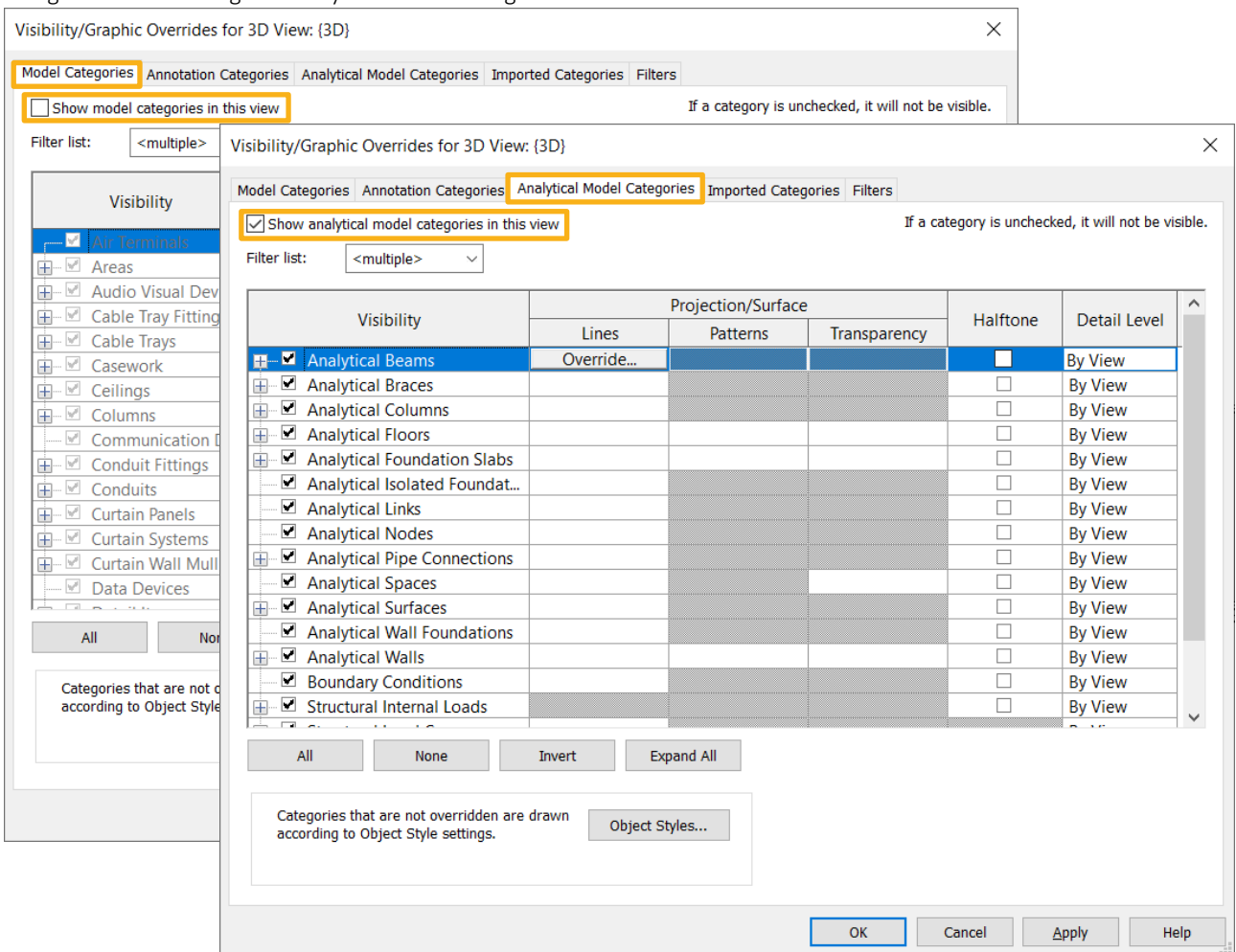

The picture below shows the structural model and the underlying analytical model in Revit for an example model.

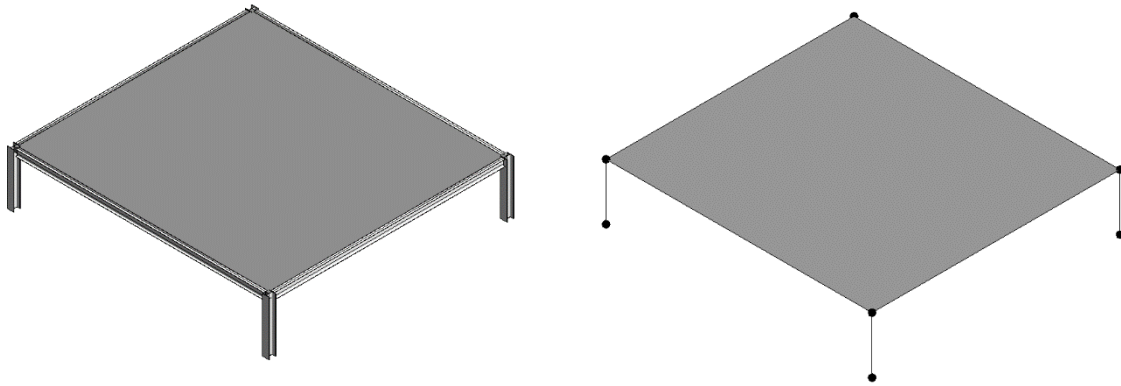

This analytical model can be checked for problems by doing a consistency check from the CADs Toolbar:

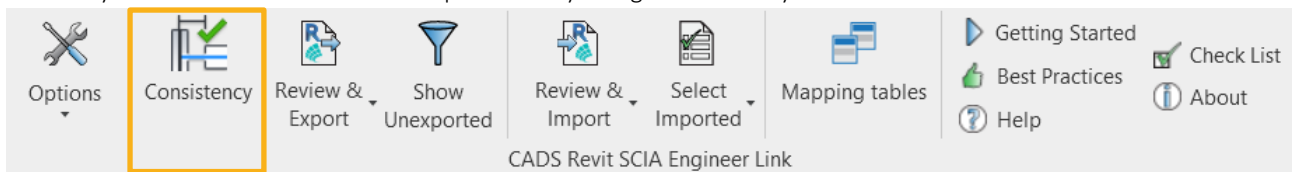

A message will be shown that the check has been completed, or some warnings might be shown that can be used to correct some inconsistencies.

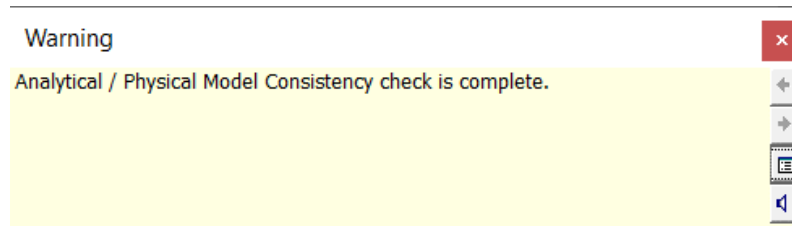

Another remark is that the model you wish to exchange need to be opened in the original Revit model. Elements from linked models are not exchanged.

3.3.2. Exporting the model to SCIA Engineer

Either from the 'Review & Export' button or the 'Options' button on the toolbar, the analysis model can be transferred to SCIA Engineer, either via direct exchange or file exchange. Open a 3D view to do so.

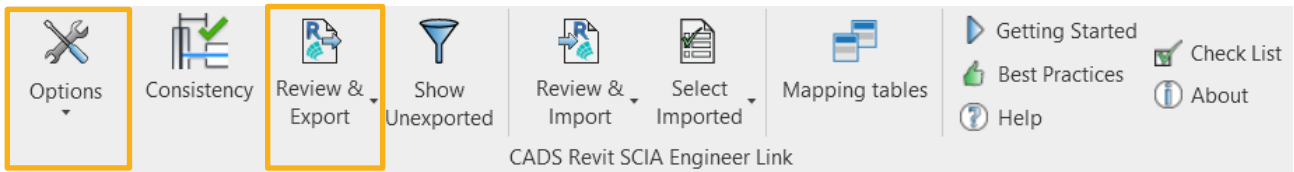

It is advised to first check the settings in the 'Options' dialog, even when exporting via the 'Review & Export' button. Make sure to check the options on the right.

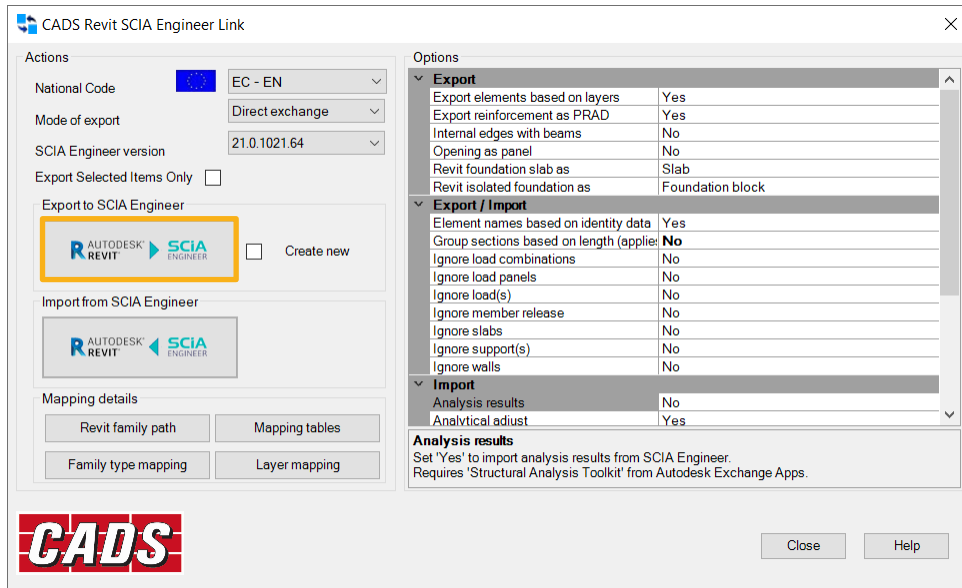

You can now click the 'Export to SCIA Engineer' button to start the exchange, or close the dialog and use the 'Review & Export' button.

It is possible you will be asked to save the Revit project before continuing to the options dialog:

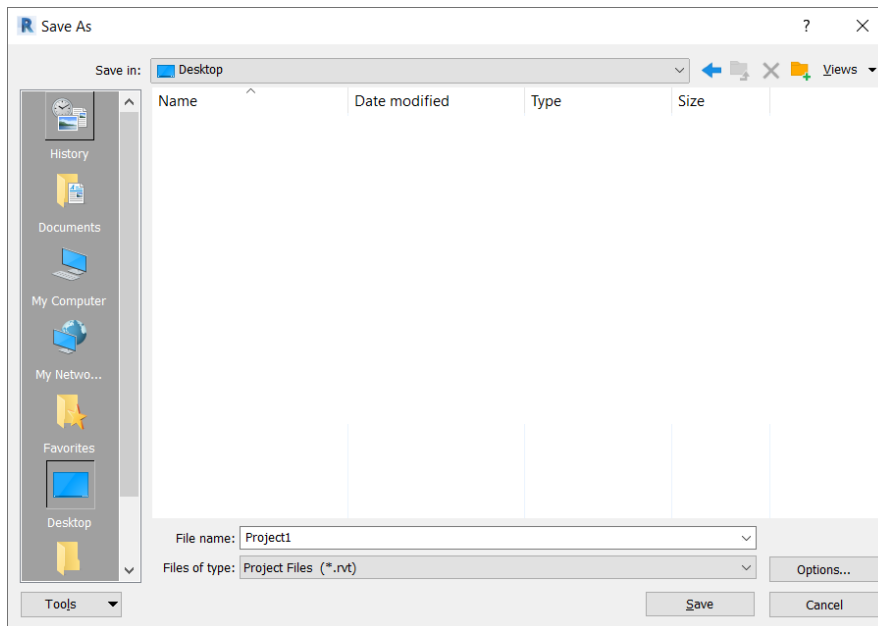

If the 'Direct exchange' mode of transfer is selected, the model will be opened in SCIA Engineer directly.
 If the 'File exchange' mode of transfer is selected, a dialog will open to save the file.

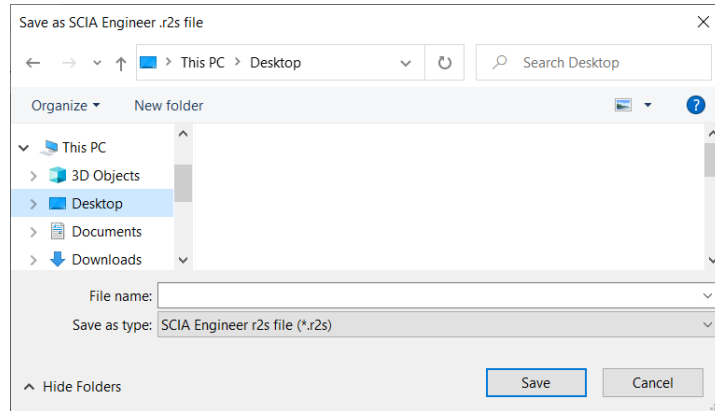

The benefit of using the 'Review & Export' button, is that an extra dialog is shown that identifies changes regarding a possible previous version of the exported/imported model.

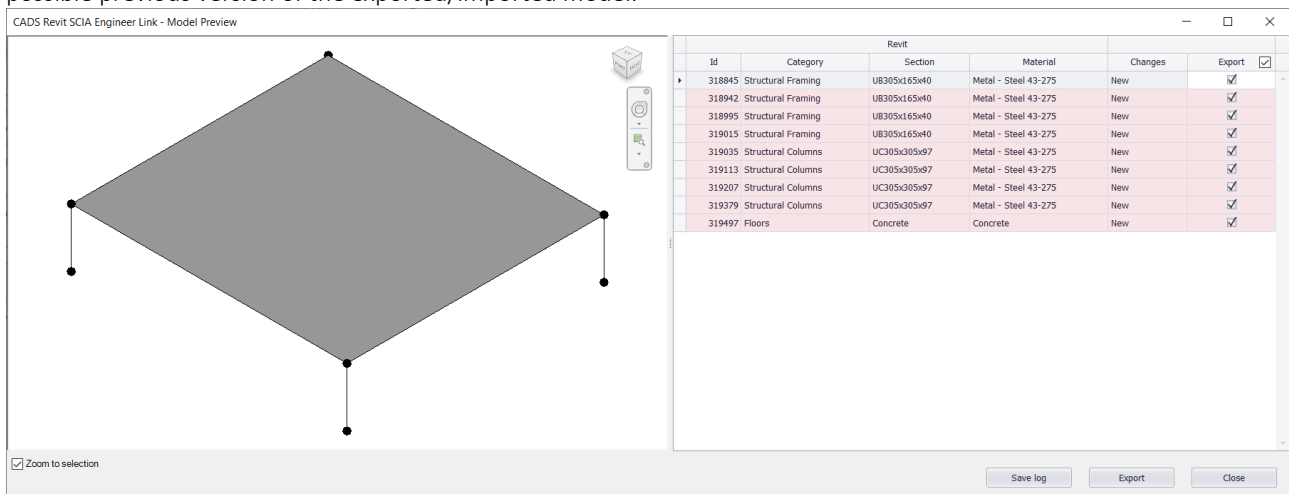

You'll have to fill in the mapping tables to define which materials and families from Revit correspond to which materials and cross-sections from SCIA Engineer.

These settings will be remembered for future exchanges, even for different models.

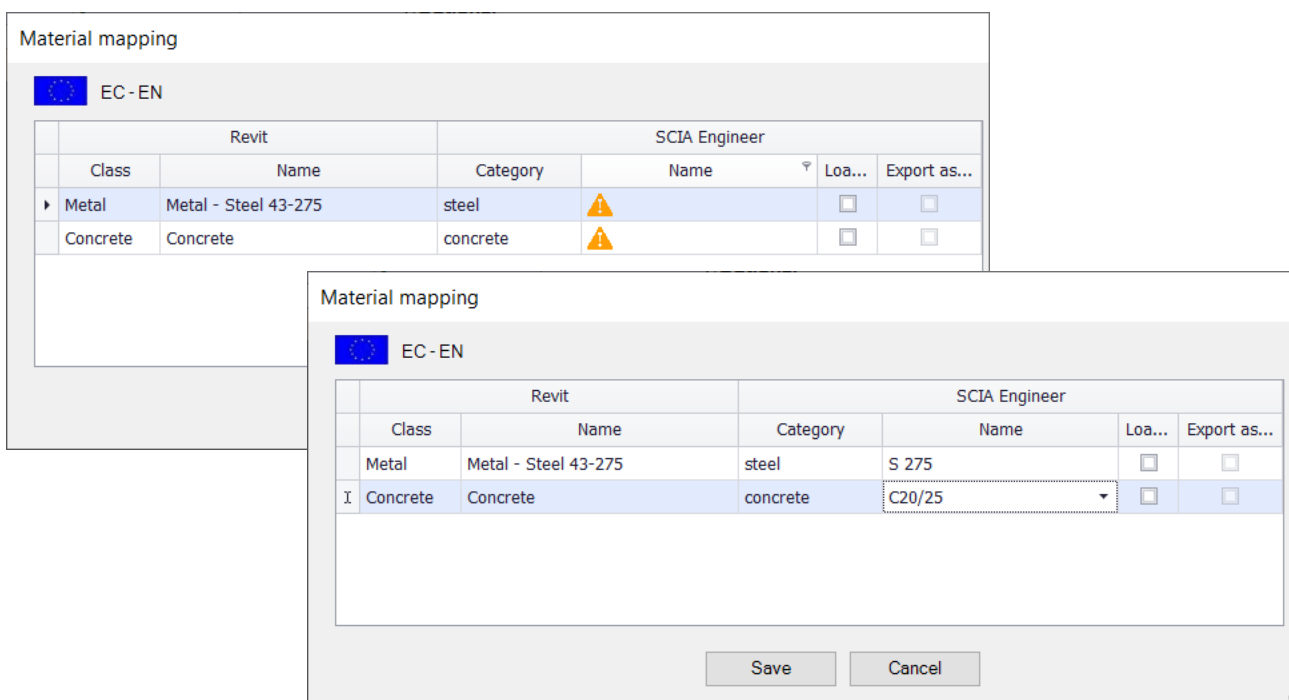

Based on the available materials and cross-sections in SCIA and Revit, the application will already make a suggestion for most mappings. This is primarily based on the material type and National Code. If all the parameters are satisfied, the application will automatically map the equivalent SCIA Engineer material. If one or more parameters do not match, the application will prompt you with an exclamation mark to map the equivalent materials.

If you are not happy with the suggested list of materials, selecting 'Load all' will show all available options in the drop-down lists so you can change/choose the best option from the selected National Code.

You can select 'Export as unknown' to later define the material in SCIA. No material name is then filled in.

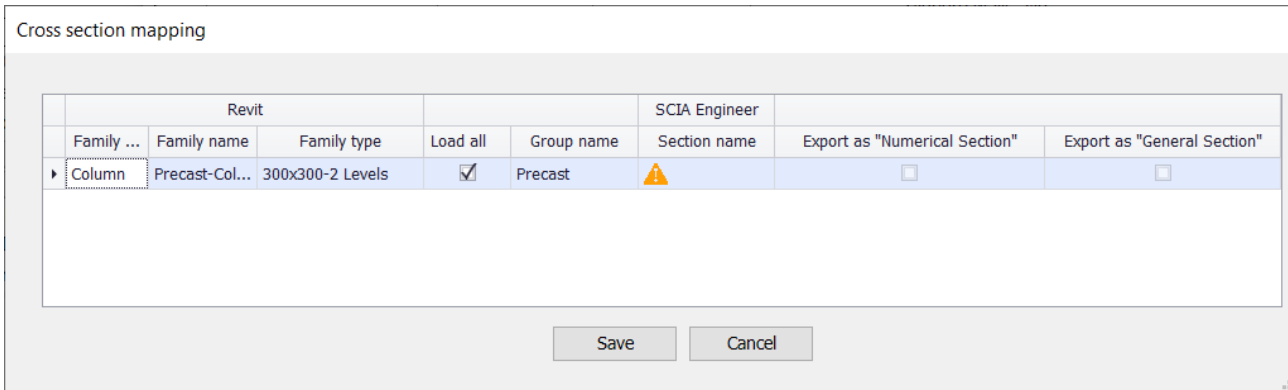

Selecting 'Export as numerical' will generate a numerical cross-section in SCIA Engineer. You can no longer choose a profile shape and section name.

Selecting 'Export as general' will generate a general cross-section in SCIA Engineer. You can no longer choose a profile shape and section name.

Note: you can check the 'Help' button in the main dialog of the Revit link application to see which sections are supported in the version of the plugin you are using.

For mapping certain parametrized sections, another dialog will appear to map the parameters or choose a custom value.

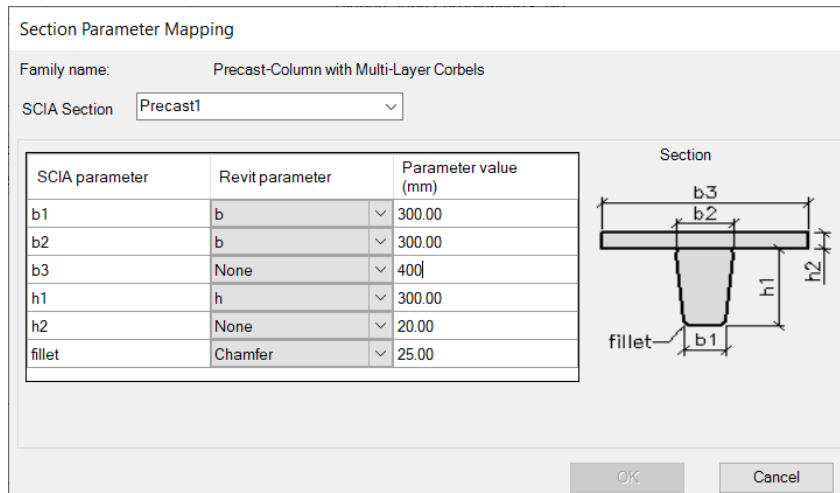

After saving the mapping, a dialog will be opened, showing the export process. You can see the number of exported, failed, and ignored entities on the left. The log is shown on the right, with a message for every step that was taken in the export. Messages for the failed entities will be shown in red. Interpreting these can help to solve the problem with the export of these entities.

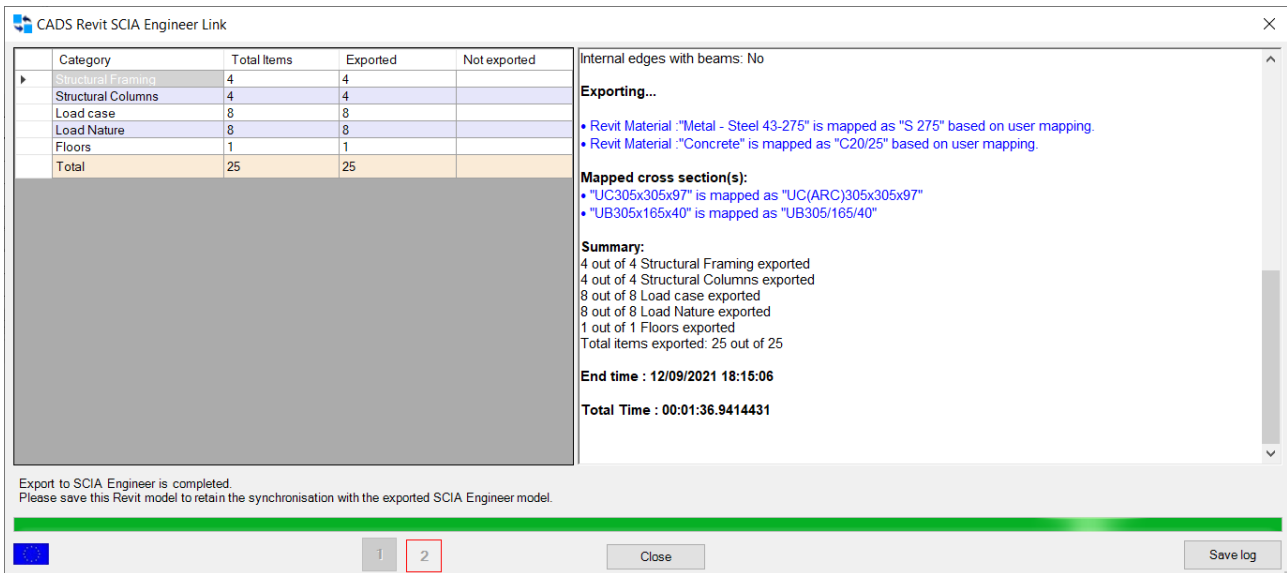

You can save a log file after export, with the button on the bottom. You will be asked to save it and open it:

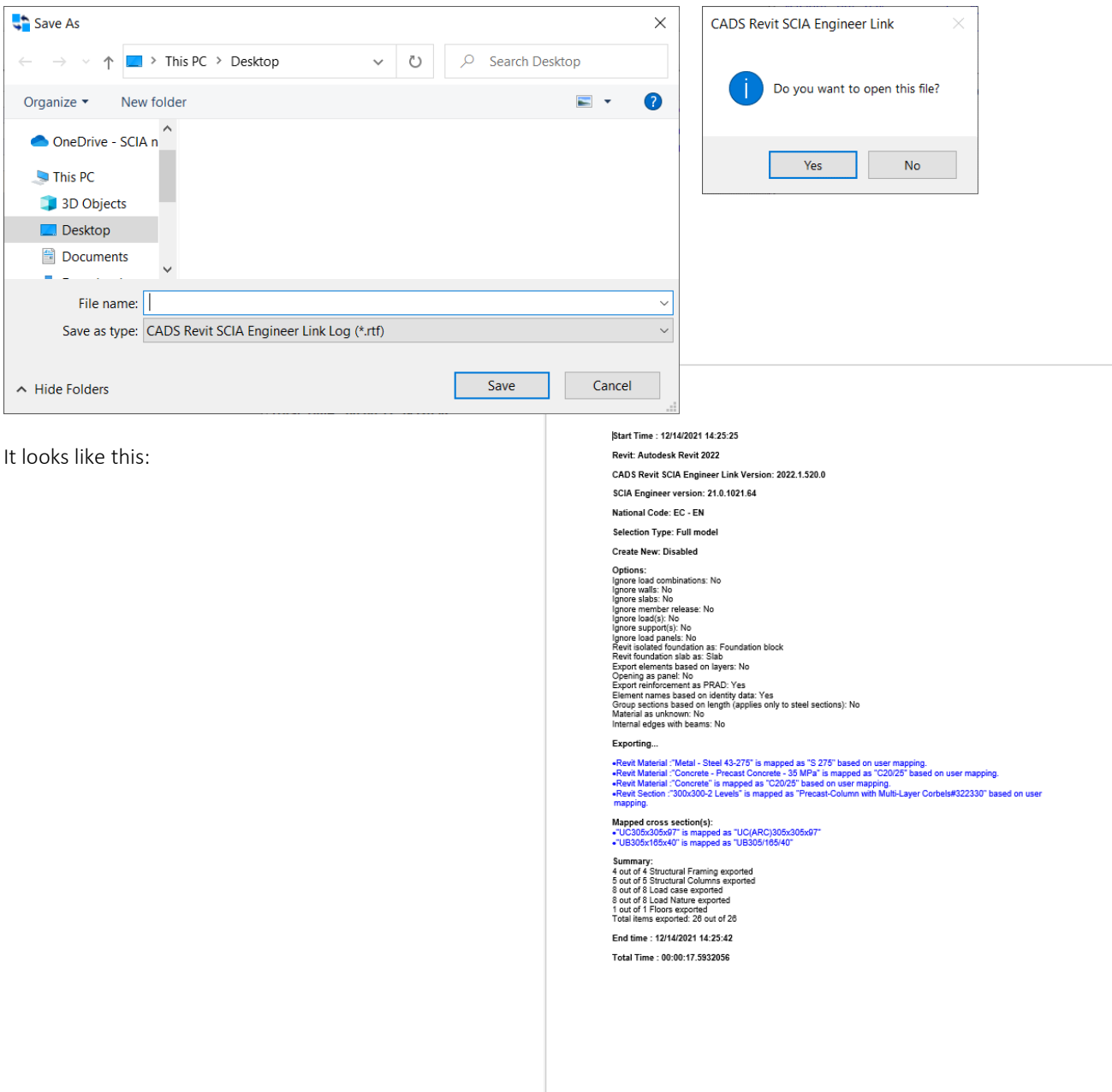

It looks like this:

3.3.3. Managing the mapping tables

You have the possibility to manage some mapping tables in the Revit link. The tables can be viewed from the options dialog or from the toolbar.

There are some differences depending on which function you use, namely which tables can be viewed, and also whether the table can be exported.

From the toolbar

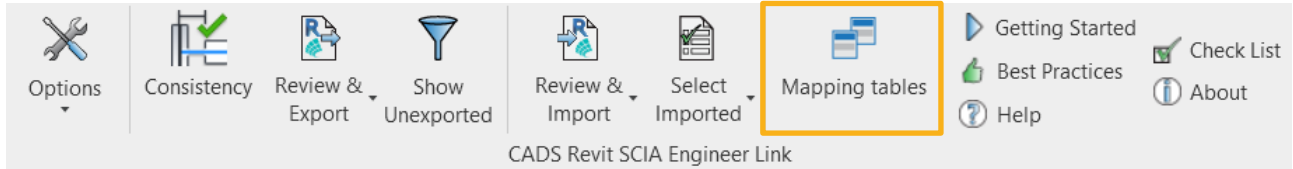

Using the function from the toolbar as shown above, opens the following dialog with the options explained below.

Export database:
Save an xml-file of the mapping table to archive or use in another instance of Revit.

Import database:
Open an xml-file of the mapping table that was saved using the 'Export database' option.

Mapping database:
Open a different table if multiple tables are saved.

Delete database:
Delete this table.

Document mapping:
Map the entities in this model using the current user table.

National Code:
Choose for which code this mapping table is used.

Save

44

MC – 20/01/2025

From the options dialog

In the options dialog, the mapping details can be viewed and edited to a certain extent.

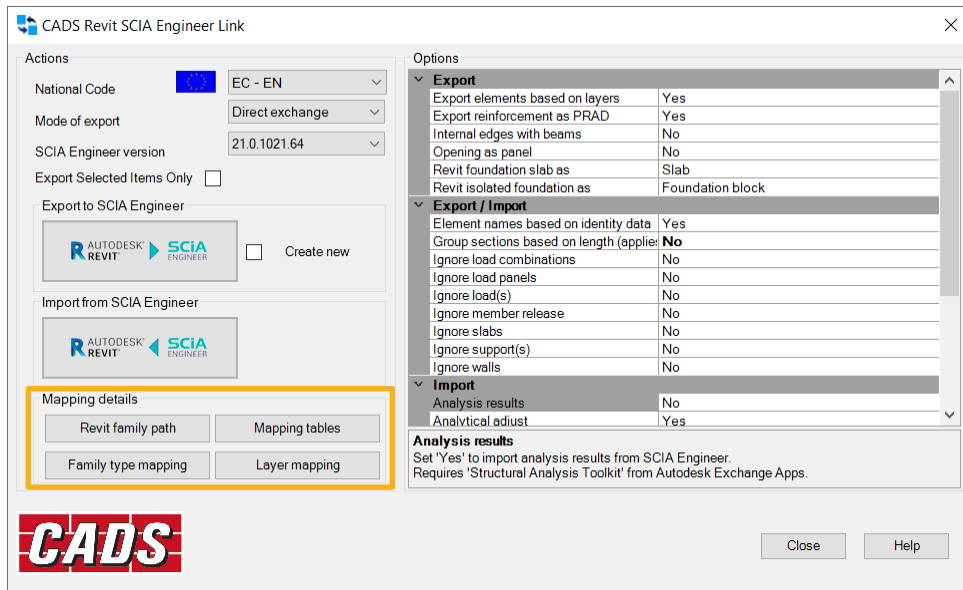

The same editing options are available for the user tables, but also the general tables from the chosen code can be viewed (not edited) here.

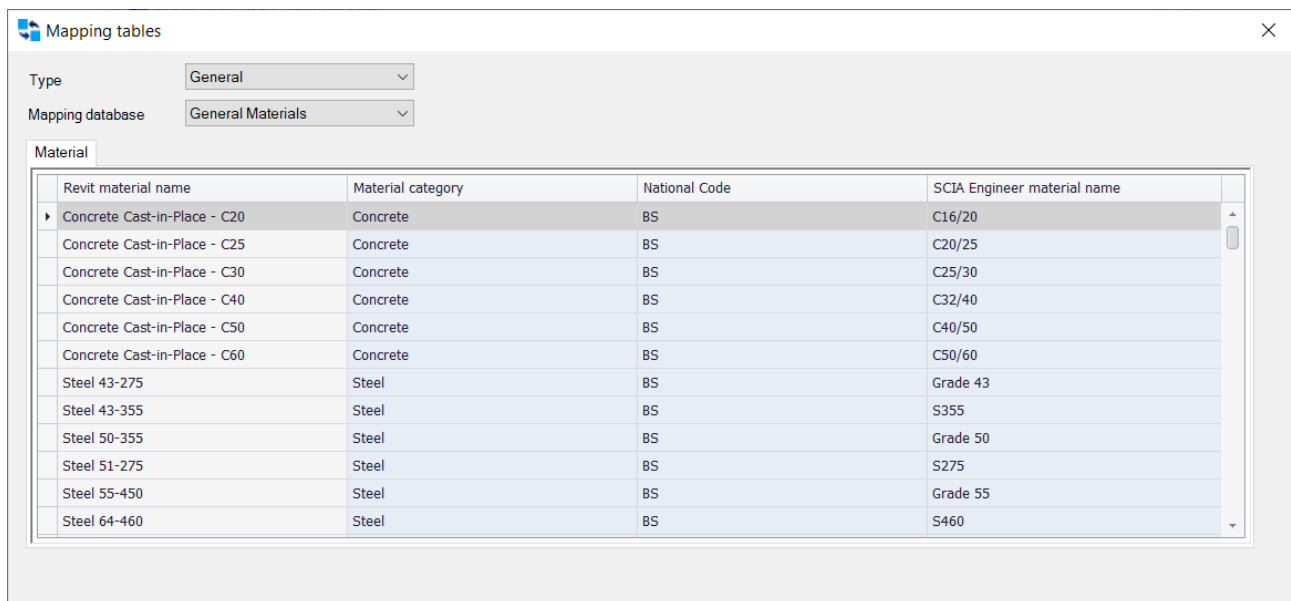

There is also a possibility to view and edit (only change the values) of the layers on which the elements will be placed.

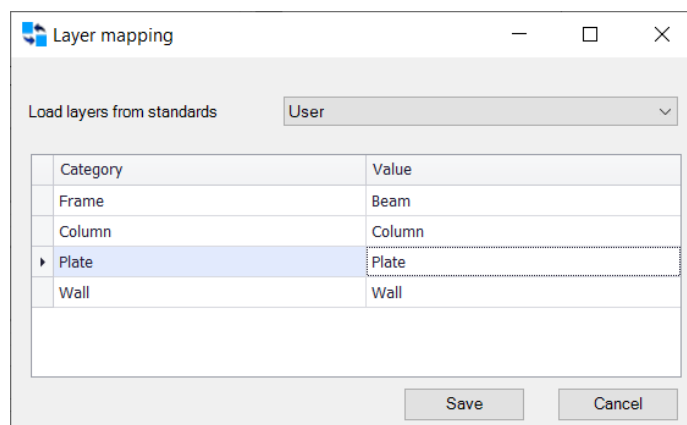

The path to the families that are used to map the cross-sections etc. in Revit, can be chosen or added here:

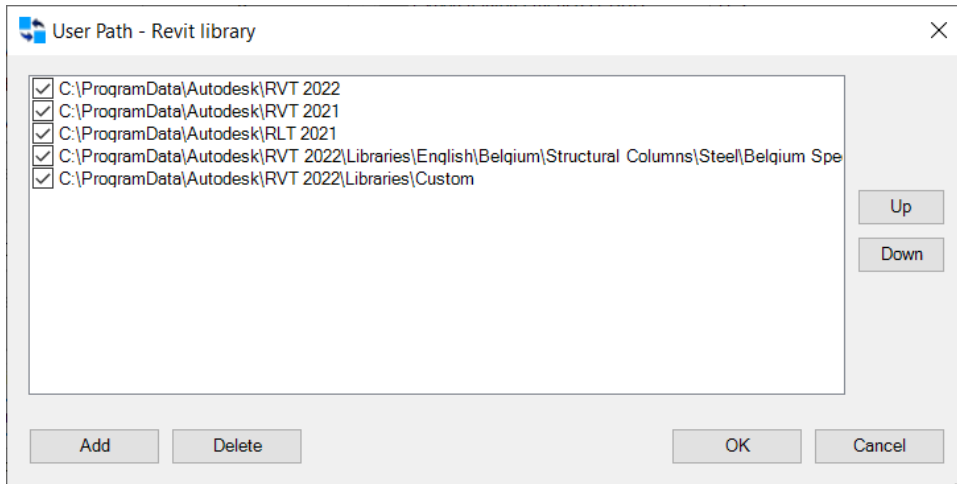

It's possible to add your own custom families. You can use these to extend the user mapping tables.

You can see the automated mappings here:

Region	Family role	Family name	Family type	Section type
Europe Specific	Frame	Circular Hollow Sections	TRON	RO
Europe Specific	Frame	Circular Hollow Sections	TRON	CHS
Europe Specific	Frame	Circular Hollow Sections	TRON	CFCHS
Europe Specific	Frame	Circular Hollow Sections	TRON	CHS(Ce)
Europe Specific	Frame	Circular Hollow Sections	TRON	CHSCF
Europe Specific	Frame	Circular Hollow Sections	TRON	CHSCF(Hy)
Europe Specific	Frame	Circular Hollow Sections	TRON	MSRR
Europe Specific	Frame	Circular Hollow Sections	TRON	ROR
Europe Specific	Frame	Circular Hollow Sections	TRON	Y(CH)
Europe Specific	Frame	Flat Bars	FL	FL

3.3.4. Opening the model in SCIA Engineer

Using the 'Direct exchange' mode of transfer will open the model directly in SCIA Engineer upon export. SCIA Engineer does not need to be open before starting the export.

There are two options for opening a r2s-file in SCIA, 'Open from' and 'Update from'. The first one will start a new SCIA Engineer project to open the file, the second one will use the project that is already open, and apply the changes made in Revit while keeping any additional information that might be in the SCIA project, like load cases and combinations, supports etc.

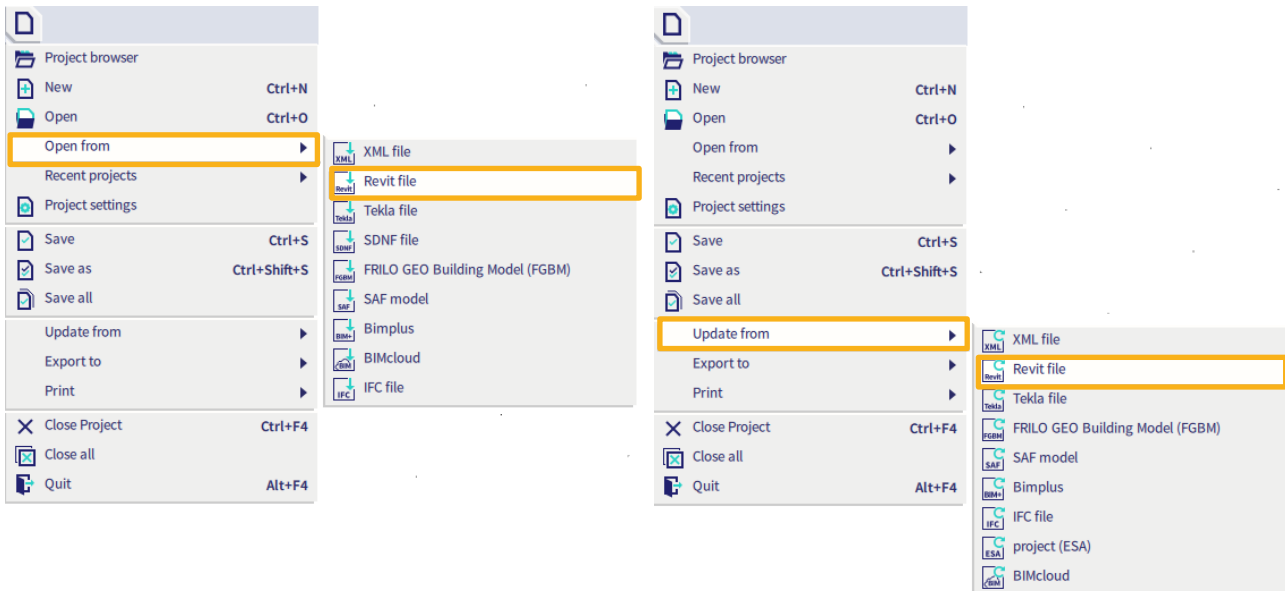

In both cases, a dialog will open, asking you to select the r2s-file.

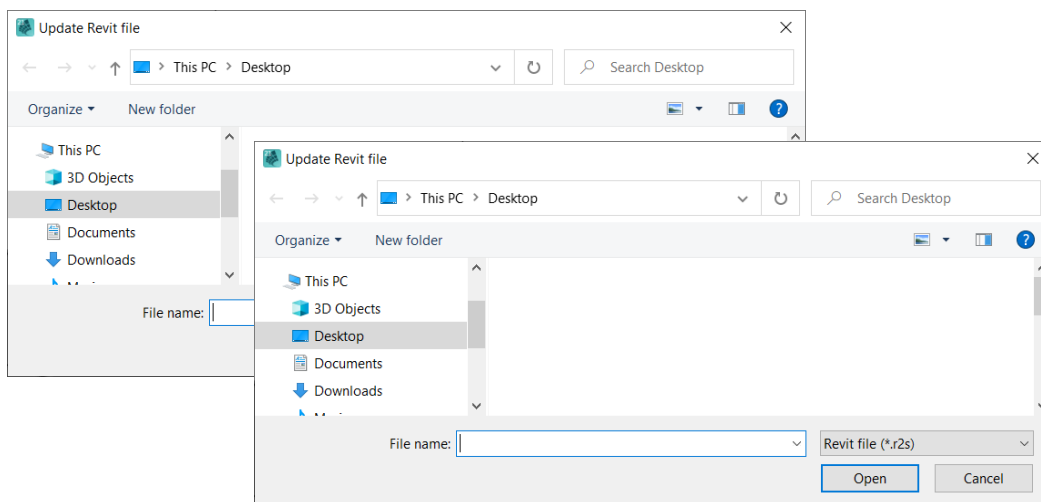

The code that was selected for the export will be shown next. It can be changed with the 'Add' button, or you can just continue using the 'Close' button.

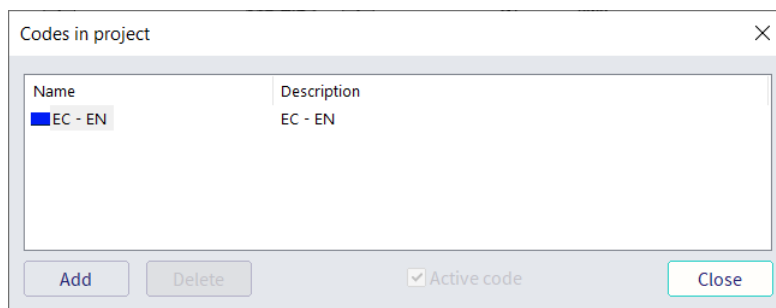

The model will now be shown in SCIA.

3.4. Exchange from SCIA to Revit

3.4.1. Exporting the model to Revit

For the 'Direct exchange' mode of transfer, a model should be opened in SCIA Engineer. No other action is required from SCIA side.

For the 'File exchange' mode of transfer, you can export a r2s-file from the menu:

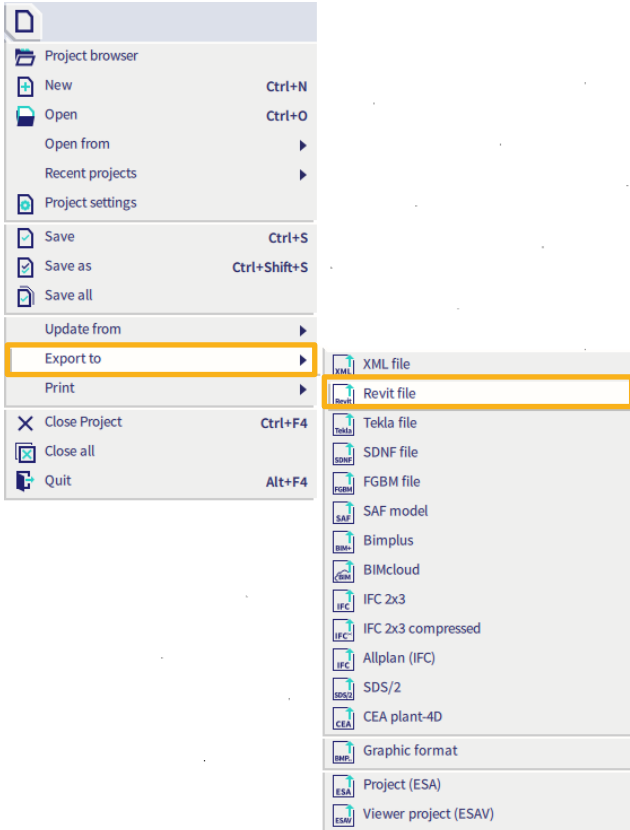

A dialog will be opened to choose a file location to save the file.

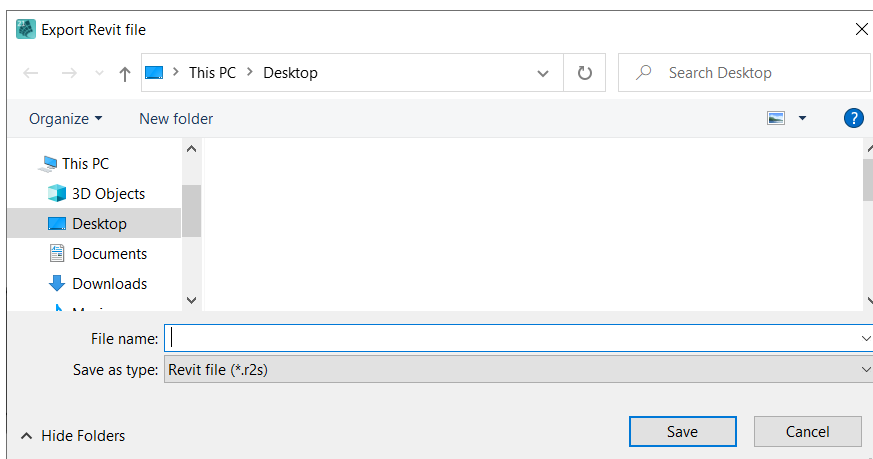

3.4.2. Opening the model in Revit

You can now open the model in Revit using the CADs Toolbar. Either use the 'Options' dialog or the 'Review & Import' function.

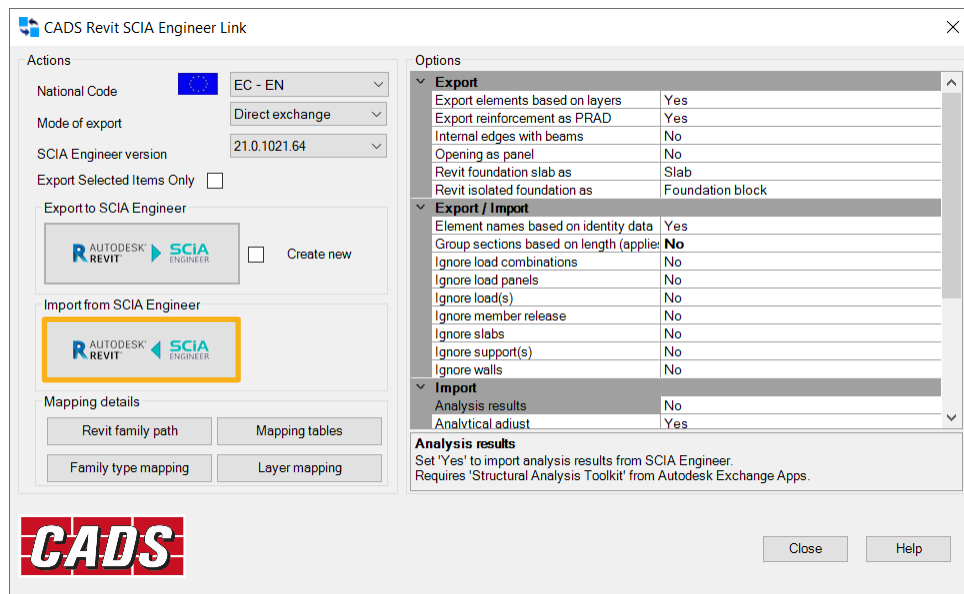
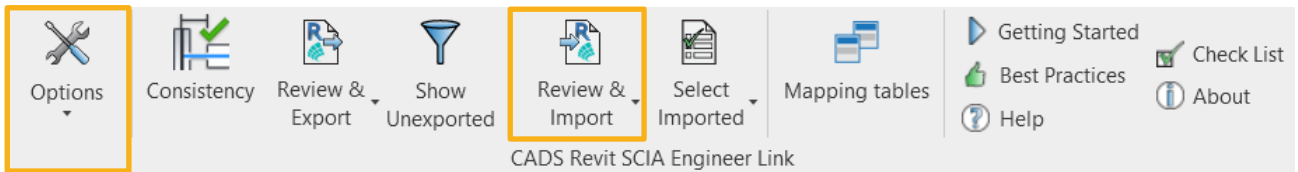

Using the 'Direct exchange' mode of transfer will open the model that is open and active in SCIA Engineer. Using the 'File exchange' mode of transfer will prompt a dialog asking to select the r2s-file to be opened.

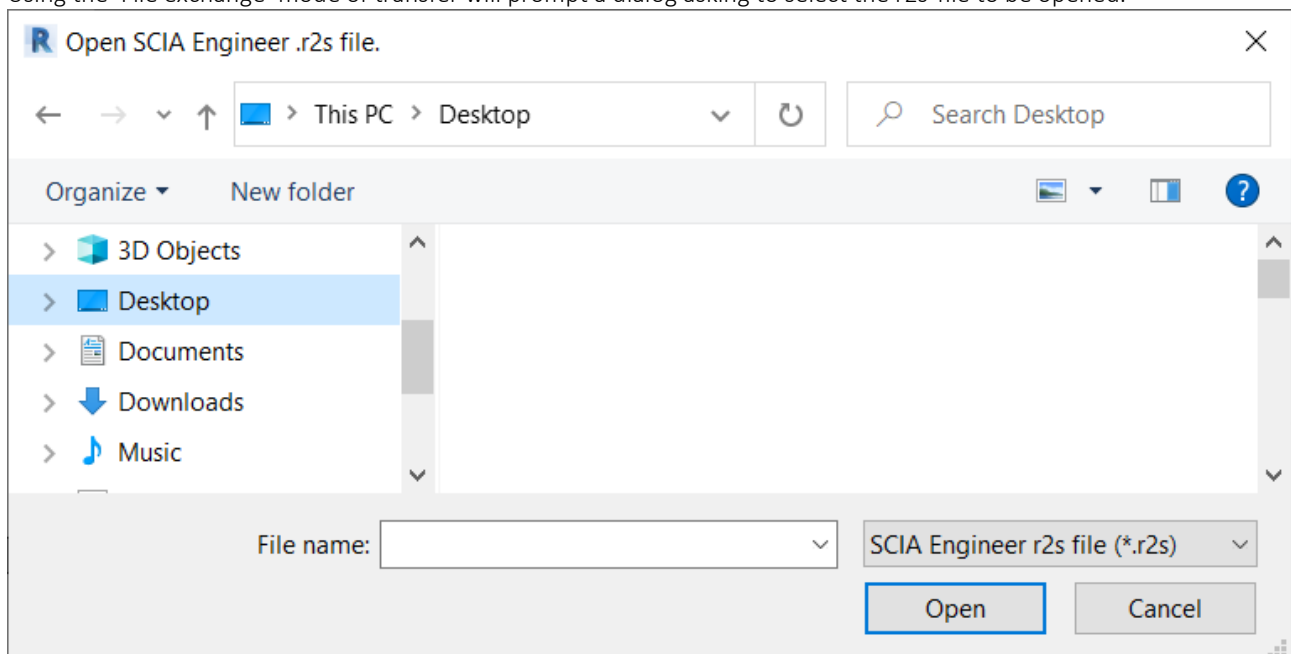

The next steps are very similar to the workflow for exporting a model from Revit. Make sure to check the options in the main dialog on the right and select the mappings in the upcoming dialogs.

Material mapping

EC - EN

SCIA Engineer			Revit			
Category	Name	Mapping database	Loa...	Name	Skip	
Steel	C25/30	General-Materials	<input type="checkbox"/>	Concrete - Cast-in-Place Concret...	<input type="checkbox"/>	

Cross section mapping

SCIA Engineer					Revit			
Section type	Section name	L...	Group name	Mapping database	Family role	Family name	Family type	Skip
CS	CS4 (General Sectio...	<input type="checkbox"/>	General CS	⚠	Column	⚠	⚠	<input type="checkbox"/>

In case you are not satisfied with the available sections for mapping, you can download additional cross-sections from the Autodesk website, like the following families:

<https://knowledge.autodesk.com/support/revit/troubleshooting/caas/downloads/content/autodesk-revit-2022-content.html>

The benefit of using the Import & Review button, is that an extra dialog is shown that identifies changes regarding a possible previous version of the model. You can choose which changes to apply in the model.

CADS Revit SCIA Engineer Link - Model Preview

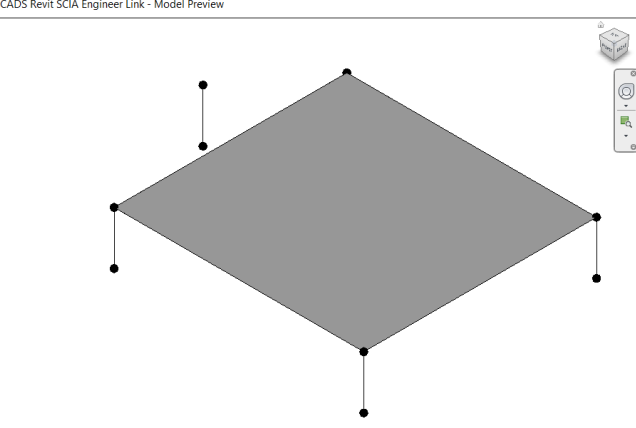

Zoom to selection

Revit	SCIA		Changes	Import
Id	Member name	Type		<input checked="" type="checkbox"/>
319035	Member#319035	Column	Rotation	<input checked="" type="checkbox"/>
319113	Member#319113	Column	Rotation	<input checked="" type="checkbox"/>
319207	Member#319207	Column	Rotation	<input checked="" type="checkbox"/>
319379	Member#319379	Column	Rotation	<input checked="" type="checkbox"/>
322364	Member#322364	Column	Deleted	<input checked="" type="checkbox"/>

The log shows the steps taken in the import process. Any failed items will be shown in red.

CADs Revit SCIA Engineer Link

Category	Total Items	Imported	Not imported
Load case	9	1	8
Column	4	4	0
Total	13	5	8

- Column - 319113 : The material of the member 'Member#319113' is updated.
- Column - 319207 : The material of the member 'Member#319207' is updated.
- Column - 319379 : The material of the member 'Member#319379' is updated.

Deleted members:

- Structural Columns:322364-Member#322364

Mapped cross section(s):

- "CS" is mapped as "UC305x305x97"

Summary
1 out of 9 Load case imported
4 out of 4 Column imported
Total items imported: 5 out of 13

End time : Tuesday, 14 December 2021 16:06:33

Total Items00:00:03.4258939

Import from SCIA Engineer completed.

1 2 Close Save log

After closing this dialog, the model is shown in Revit.

Chapter 4: Exchange via the Tekla-link



The CADS Tekla SCIA Engineer link facilitates the bi-directional exchange of members, loads, and supports between Tekla Structures and SCIA Engineer and in doing so plays a vital role in the overall Building Information Modelling (BIM) process. A structure modelled in Tekla Structures can be transferred to SCIA Engineer for structural analysis and design using CADS Tekla SCIA Engineer link. When the structural analysis and design has been completed in SCIA Engineer, the updated model can be sent back to Tekla Structures. The modelling - analysis - design process requires numerous iterations to arrive at the final design. CADS Tekla SCIA Engineer link will save time by avoiding duplication and reducing errors.

! Note: Make sure you read the introduction and understand the concept of structural and analytical models.

4.1. Installation of the Tekla-link

There are two ways to install the Tekla plugin. It can be done from the setup of SCIA Engineer, or the plugin can be installed from a separate setup.

It's possible but not necessary to have SCIA Engineer installed on the same computer as Tekla and the Tekla plugin. This means that employees that use Tekla but don't work with SCIA Engineer, can still install the plugin and provide exported files to the Engineers that use SCIA Engineer, or import files coming from SCIA Engineer.

The use of these files in SCIA Engineer, and exporting from SCIA Engineer to Revit, is then possible as long as the needed modules for Tekla Exchange are available in the SCIA Engineer license.

The plugin can be installed from the SCIA Engineer Setup in the following way. First, download the SCIA Engineer setup from the website:

<https://www.scia.net/en/support/downloads>

This is recommended over modifying the existing installation directly, because all the necessary files and relations are directly available in the setup. Otherwise, a message could appear stating that some files cannot be found.

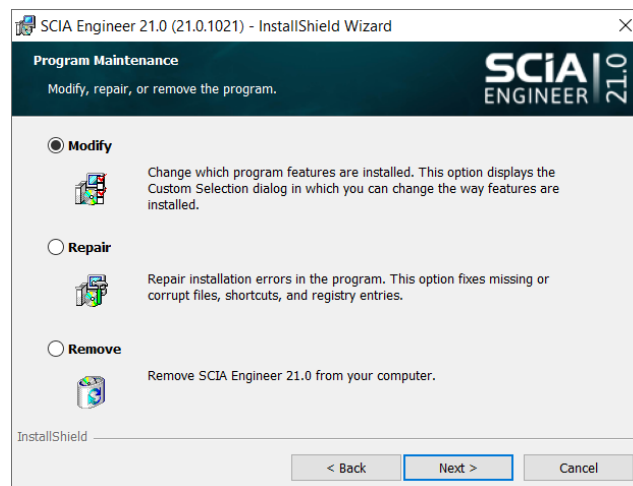

Choose to 'Modify' the installation, click 'Next >' and select the Revit plug-in under Add-ons. Select 'This feature will be installed on local hard drive'.

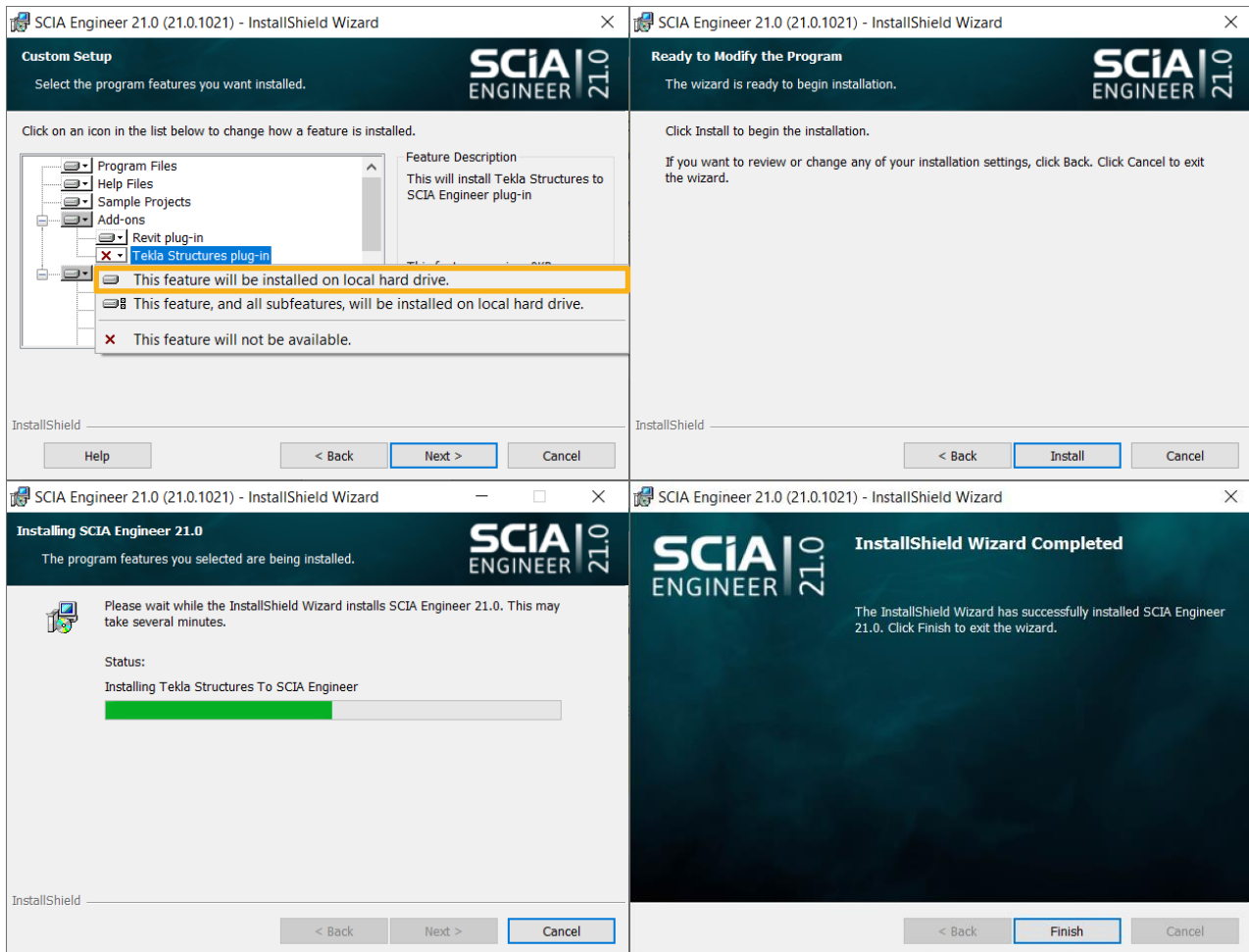

The latest version of the plugin and its separate setup should be available on the SCIA Website:
<https://www.scia.net/en/support/downloads/plugin-tekla-structures-scia-engineer>

And on the CADs website:
<https://cads.co.uk/support-and-learning/product-downloads-updates/>

The installation is straightforward and is shown in the images below. Recent versions of the plugin support two versions of Tekla at the same time. Older ones were installed only for one version of Tekla, so if there were multiple versions of Tekla installed on your computer, it would automatically take the 'default' version.

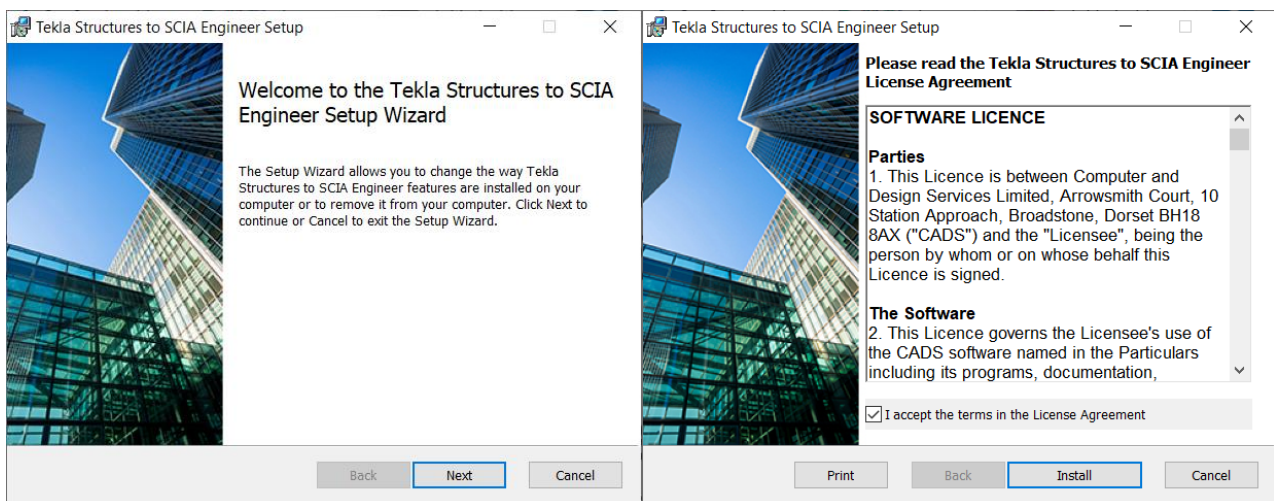

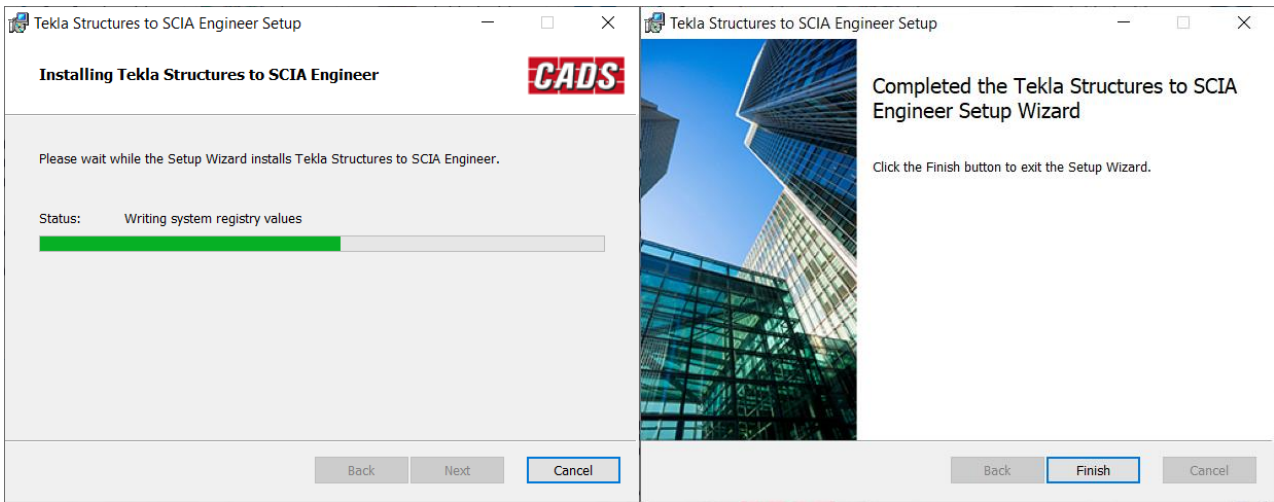

The following Application is now available under 'Applications & Components' in the menu on the right in Tekla Structures.

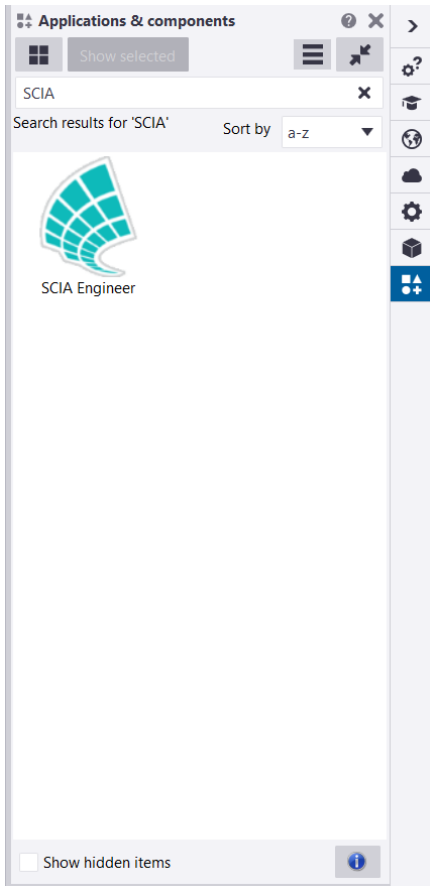

4.2. Overview

Here's an overview of all available options:

National Code:

Choose the code according to which the model is built in Tekla (profiles, materials...). This is only used for export to SCIA Engineer.

SCIA Engineer version:

Browse to the installation path of SCIA Engineer and choose the version you wish to make the exchange to/from. This is only necessary for the direct exchange method.

Mode of transfer:

'Direct exchange'

The model is sent directly to or from SCIA. This is only possible when SCIA is installed and open on this computer. The correct SCIA Engineer version needs to be specified in the next option and a valid Tekla Exchange module must be part of the SCIA Engineer license.

'File exchange'

An exchange file is exported and saved, or imported. This is possible with or without installation of SCIA Engineer on this computer.

Export items:

Choose whether you wish to only export the current selection instead of the entire model.

Export as:

Choose whether you want to import the model as a new SCIA Engineer project or update the one that is open. This is only necessary for the direct exchange method.

Export to SCIA Engineer:

'Direct exchange' as Mode of export: The model open in Tekla will be transferred to SCIA Engineer.

'File exchange' as Mode of export: The Tekla model will be exported as a t2s-file. You will get the option to choose a save location.

Import from SCIA Engineer:

'Direct exchange' as Mode of export:

The model open in SCIA Engineer will be transferred to Tekla.

'File exchange' as Mode of export:

You will get the option to choose a s2t-file to open in Tekla.

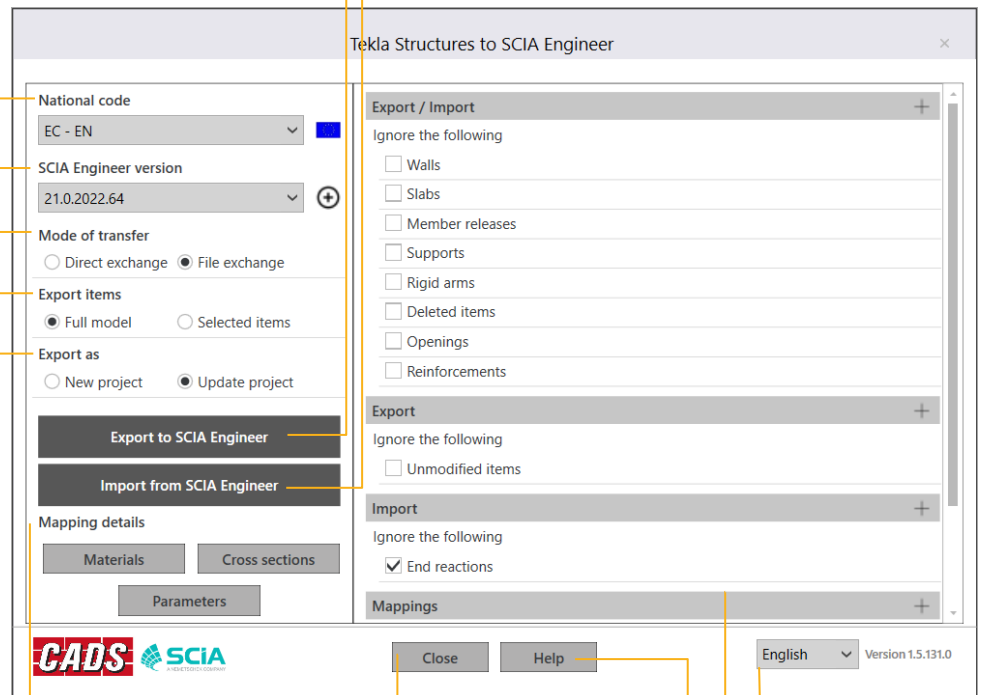

Mapping details:

Tables for mapping the Tekla materials, cross sections, and other parameters to the corresponding SCIA properties. Mappings that were made for previous model exchanges can be viewed here. They cannot be edited or extended here but will be shown upon exchanging a new model.

Close:

Close the application.

Help:

A manual from CADs will be opened for using the plugin. This includes release notes and information for supported versions.

Language:

The language of the plugin can be changed here.

Options:

Specify which objects or results should be exported/imported.

Note that the **direct exchange** method is (due to technical limitations) only linked to one SCIA Engineer interface. For SCIA21 and SCIA22, this is the old interface, so SCIA Engineer XX.X Legacy. Starting from SCIA 24 the plugin is linked to the new interface.

Although the Tekla link is a bidirectional link it uses two different file formats for the **file exchange**. If you export from SCIA Engineer to Tekla Structures the *.s2t-file format (SCIA2Tekla) is used. If you export from Tekla Structures to SCIA Engineer, the *.t2s-file format (Tekla2SCIA) is used.

4.3. Exchange from Tekla to SCIA

4.3.1. Generating the analytical model in Tekla

As referred to in chapter 1, modelling a structure in Tekla concerns the structural model. For exchange with SCIA Engineer, we are interested in the analytical model. This representation must be generated in Tekla before exporting a model to SCIA Engineer.

In Tekla, this functionality is called ‘A & D models’ and can be found in the ‘Analysis & Design’ toolbar.



Select ‘New’ to create an analytical model.

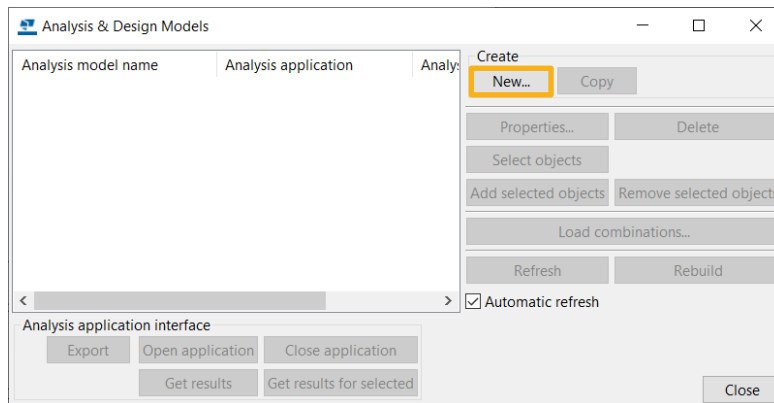

The following dialog opens. You can define the properties as needed.

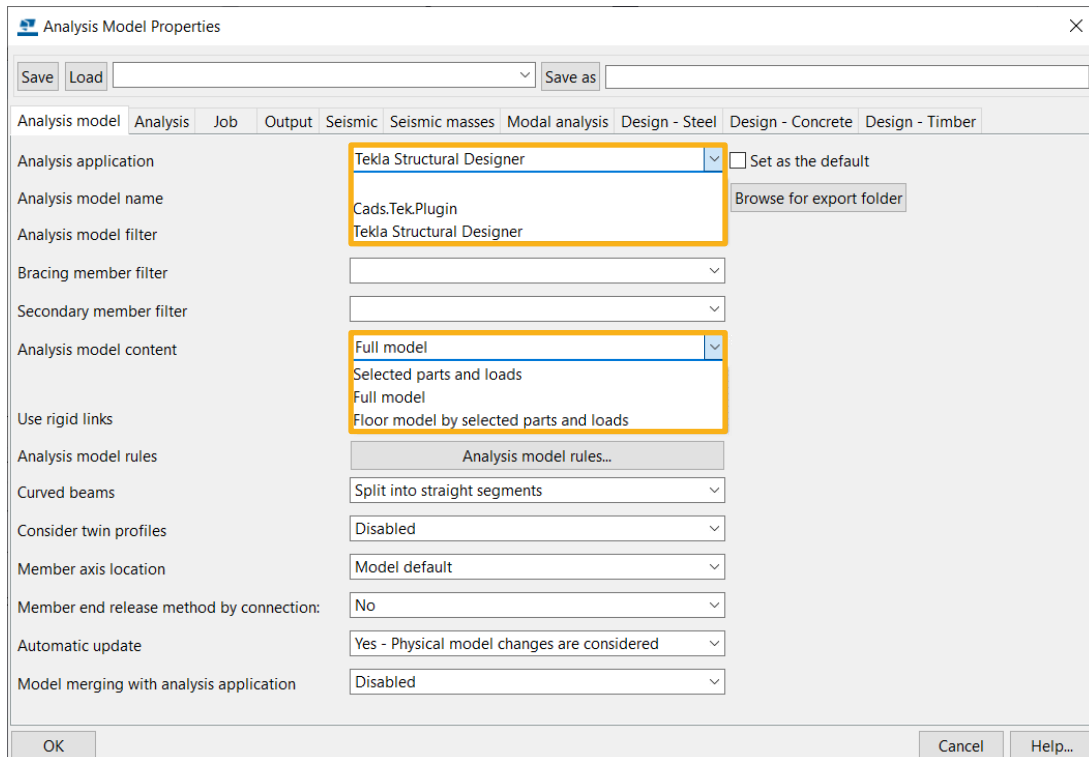

Some important settings are:

- Analysis application: The analysis model will be generated based on different rules which may cause one application to be more suited for your model than another. This mainly affects the position of the member system lines and nodes.
- Analysis model content: Carefully choose to generate a model based on selected parts or the full model.
- Analysis model filter: if you have some connections in the model, (end plates, bolts...) these should not be exported to the analytical model and can be filtered out here.

You can create multiple analytical models. Upon exchange with SCIA, you can then select which model to use.

Analytical properties per member can be shown and changed with the function 'Get analysis properties' under the Analysis & Design tab.

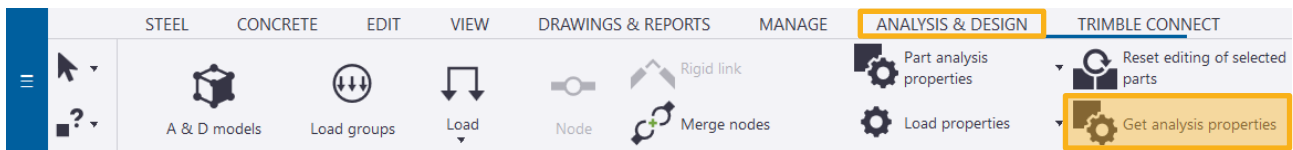

The following dialog then opens with settings that affect the analysis model. The 'Axis' and 'Keep axis position' options can for instance be changed here.

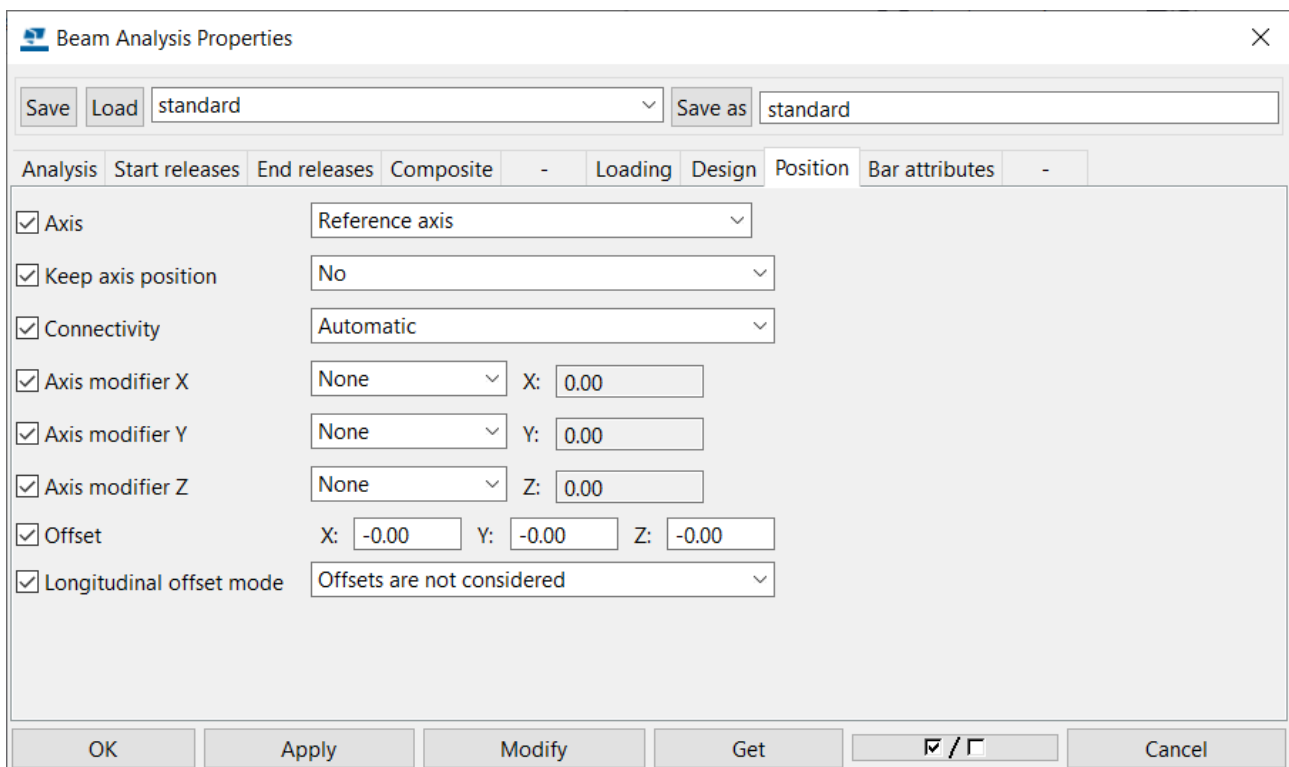

More information about the analytical model and properties can be found on the Tekla support website:

https://support.tekla.com/doc/tekla-structures/2021/ana_working_with_analysis_design_models

https://support.tekla.com/doc/57ekla-structures/2021/ana_parts_analysis_properties

And also, in the CADs manual that can be opened from the 'Help' button in the main dialog of the Tekla link application.

4.3.2. Exporting the model to SCIA Engineer

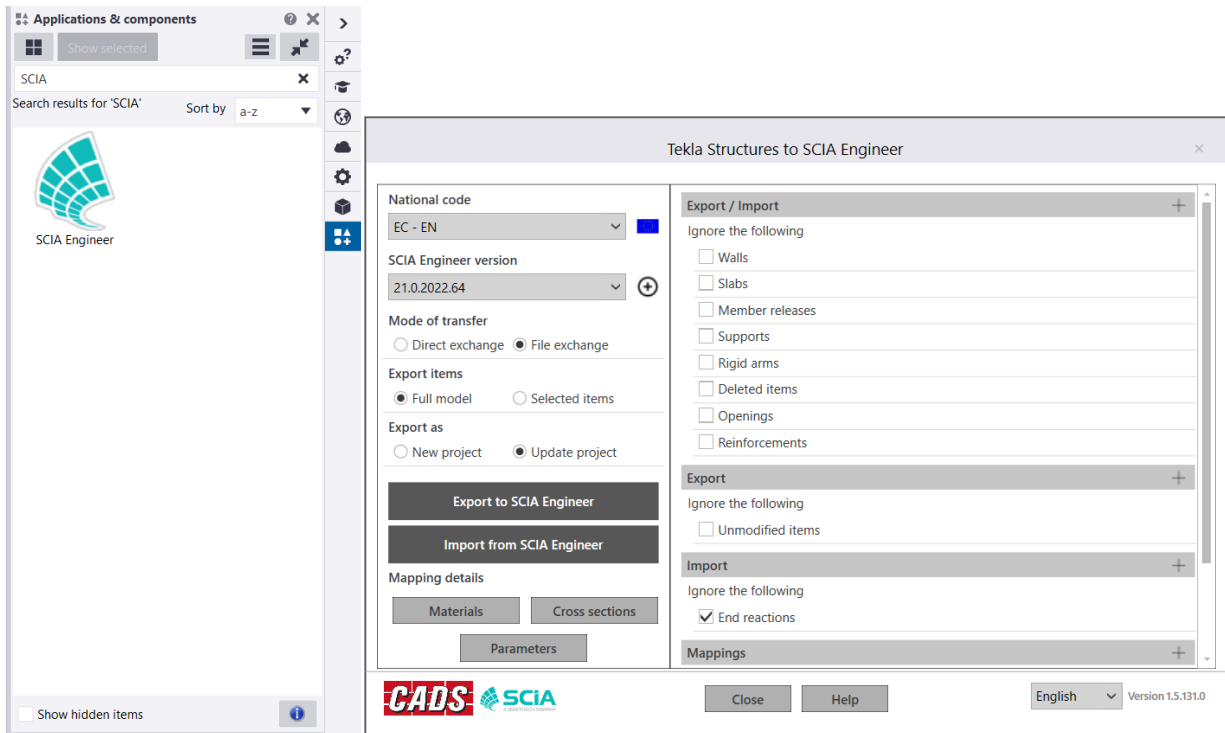

By opening the SCIA Engineer application and selecting the desired settings in the dialog, the analysis model can now be transferred to SCIA Engineer, either via direct exchange or file exchange.

Make sure to check the options on the right. Some extra information about the mapping options in this dialog: If 'Export as Unknown' is checked, the program will not prompt you for mapping a material whenever a material is not found in the mapping database.

If 'Show mapping dialog' is checked, the program will show the mapping dialog during export/import even if all the material/sections are found in the mapping database for us to verify.



Click the 'Export to SCIA Engineer' button to start the exchange.

If the 'Direct exchange' mode of transfer is selected, the model will be opened in SCIA Engineer directly. If the 'File exchange' mode of transfer is selected, a dialog will open to save the file.

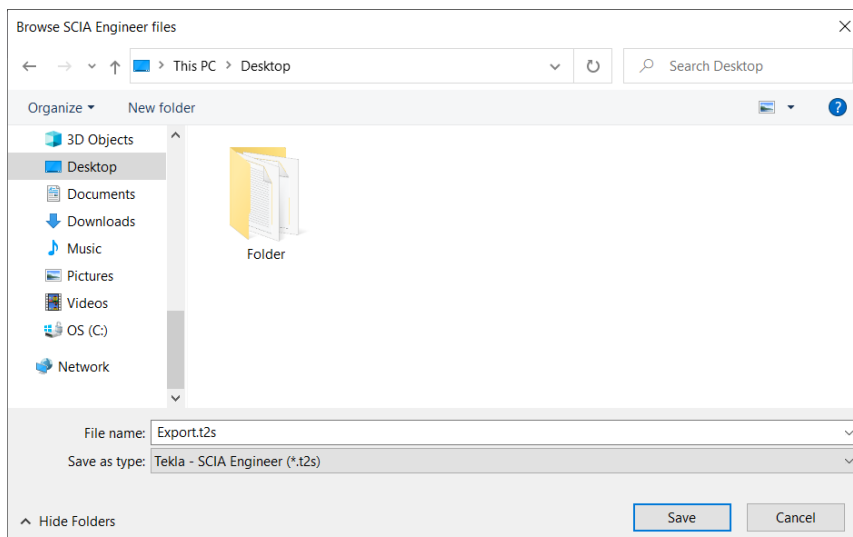

If multiple analysis models were created, a dialog will ask you to select the one you would like to use:

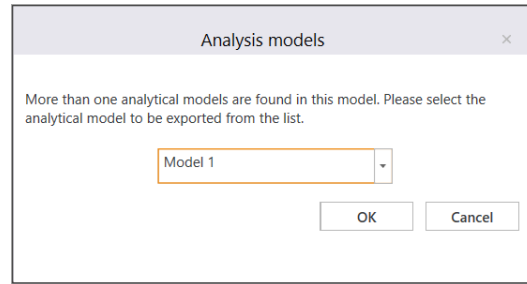

You'll have to fill in the mapping tables to define which materials and cross-sections from Tekla correspond to which materials and cross-sections from SCIA Engineer.

These settings will be remembered for future exchanges, even for different models.

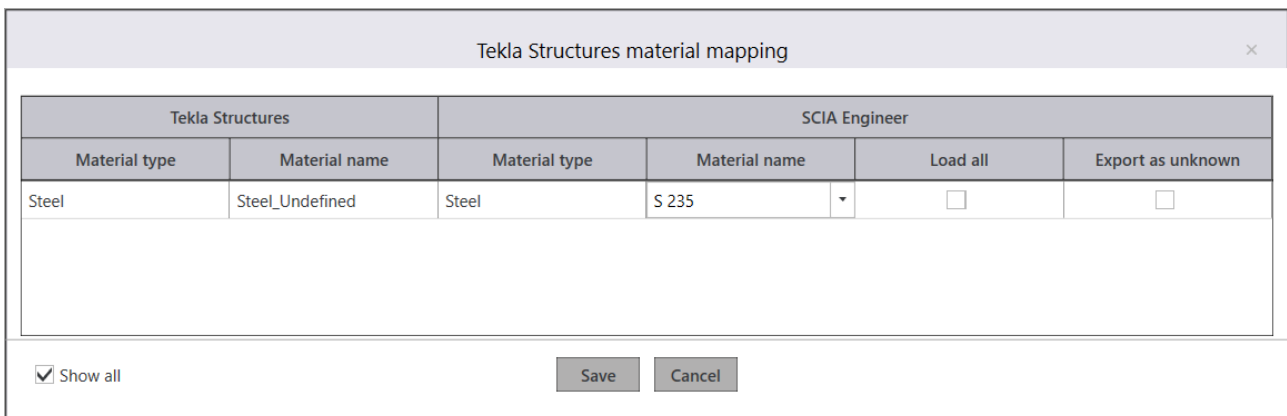

Based on the available materials and cross-sections in SCIA and Tekla, the application will already make a suggestion for most mappings. This is primarily based on the material type and National Code. If all the parameters are satisfied, the application will automatically map the equivalent SCIA Engineer material. If one or more parameters do not match, the application will prompt you with an exclamation mark to map the equivalent materials.

If you are not happy with the suggested list of materials, selecting 'Load all' will show all available options in the drop-down lists so you can change/choose the best option from the selected National Code.

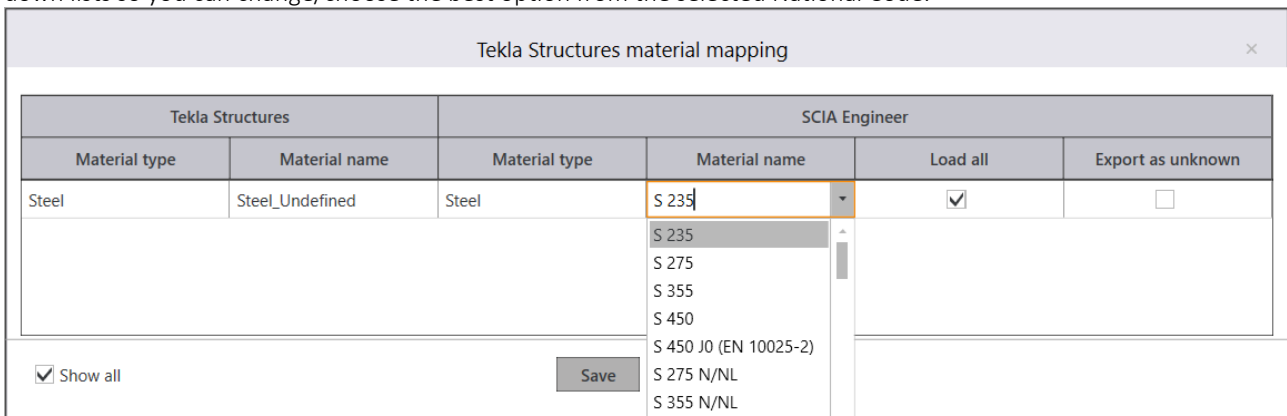

You can select 'Export as unknown' to later define the material in SCIA. No material name is then filled in.

Tekla Structures material mapping
✕

Tekla Structures		SCIA Engineer			
Material type	Material name	Material type	Material name	Load all	Export as unknown
Steel	Steel_Undefined	Steel		<input type="checkbox"/>	<input checked="" type="checkbox"/>

Show all

Tekla Structures section mapping
✕

Tekla Structures		SCIA Engineer				
Section name	Material type	Profile shape	Section name	Load all	Export as Numerical	Export as General
L70/7	Steel	L Section	L70X7	<input type="checkbox"/>	<input type="checkbox"/>	<input type="checkbox"/>
IPE160	Steel	I Section	IPE160	<input type="checkbox"/>	<input type="checkbox"/>	<input type="checkbox"/>
IPE270	Steel	I Section	IPE270	<input type="checkbox"/>	<input type="checkbox"/>	<input type="checkbox"/>
IPE220	Steel	I Section	IPE220	<input type="checkbox"/>	<input type="checkbox"/>	<input type="checkbox"/>
IPE240	Steel	I Section	IPE240	<input type="checkbox"/>	<input type="checkbox"/>	<input type="checkbox"/>
HEA140	Steel	I Section	HEA140	<input type="checkbox"/>	<input type="checkbox"/>	<input type="checkbox"/>
HEA160	Steel	I Section	HEA160	<input type="checkbox"/>	<input type="checkbox"/>	<input type="checkbox"/>
IPE100	Steel	I Section	IPE100	<input type="checkbox"/>	<input type="checkbox"/>	<input type="checkbox"/>
HEA240	Steel	I Section	HEA240	<input type="checkbox"/>	<input type="checkbox"/>	<input type="checkbox"/>

Show all

Selecting 'Export as numerical' will generate a numerical cross-section in SCIA Engineer. You can no longer choose a profile shape and section name.

Selecting 'Export as general' will generate a general cross-section in SCIA Engineer. You can no longer choose a profile shape and section name.

Tekla Structures section mapping
✕

Tekla Structures		SCIA Engineer				
Section name	Material type	Profile shape	Section name	Load all	Export as Numerical	Export as General
L70/7	Steel	L Section	L70X7	<input type="checkbox"/>	<input checked="" type="checkbox"/>	<input type="checkbox"/>
IPE160	Steel	I Section	IPE160	<input type="checkbox"/>	<input type="checkbox"/>	<input checked="" type="checkbox"/>
IPE270	Steel	I Section	IPE270	<input type="checkbox"/>	<input type="checkbox"/>	<input type="checkbox"/>
IPE220	Steel	I Section	IPE220	<input type="checkbox"/>	<input type="checkbox"/>	<input type="checkbox"/>
IPE240	Steel	I Section	IPE240	<input type="checkbox"/>	<input type="checkbox"/>	<input type="checkbox"/>
HEA140	Steel	I Section	HEA140	<input type="checkbox"/>	<input type="checkbox"/>	<input type="checkbox"/>
HEA160	Steel	I Section	HEA160	<input type="checkbox"/>	<input type="checkbox"/>	<input type="checkbox"/>
IPE100	Steel	I Section	IPE100	<input type="checkbox"/>	<input type="checkbox"/>	<input type="checkbox"/>
HEA240	Steel	I Section	HEA240	<input type="checkbox"/>	<input type="checkbox"/>	<input type="checkbox"/>

Show all

Note: you can check the 'Help' button in the main dialog of the Tekla link application to see which sections are supported in the version of the plugin you are using.

For mapping certain parametrized sections, another dialog will appear to map the parameters or choose a custom value.

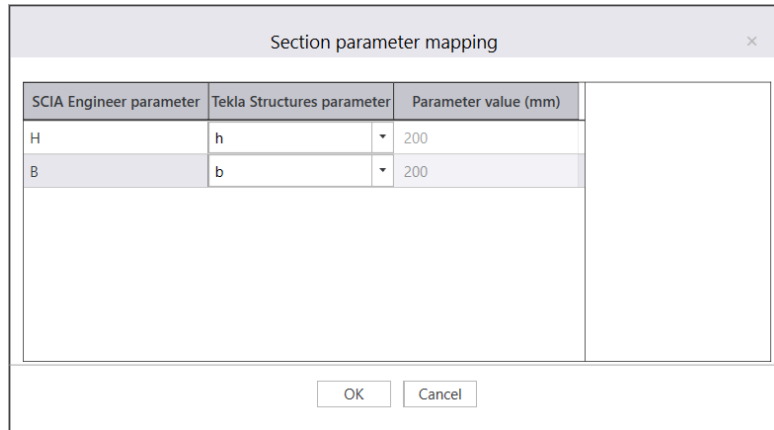

The dialog box titled "Section parameter mapping" contains a table with the following data:

SCIA Engineer parameter	Tekla Structures parameter	Parameter value (mm)
H	h	200
B	b	200

At the bottom of the dialog are "OK" and "Cancel" buttons.

After saving the mapping, a dialog will be opened, showing the export process. You can see the number of exported, failed, and ignored entities on the left. The log is shown on the right, with a message for every step that was taken in the export. Messages for the failed entities will be shown in red. Interpreting these can help to solve the problem with the export of these entities.

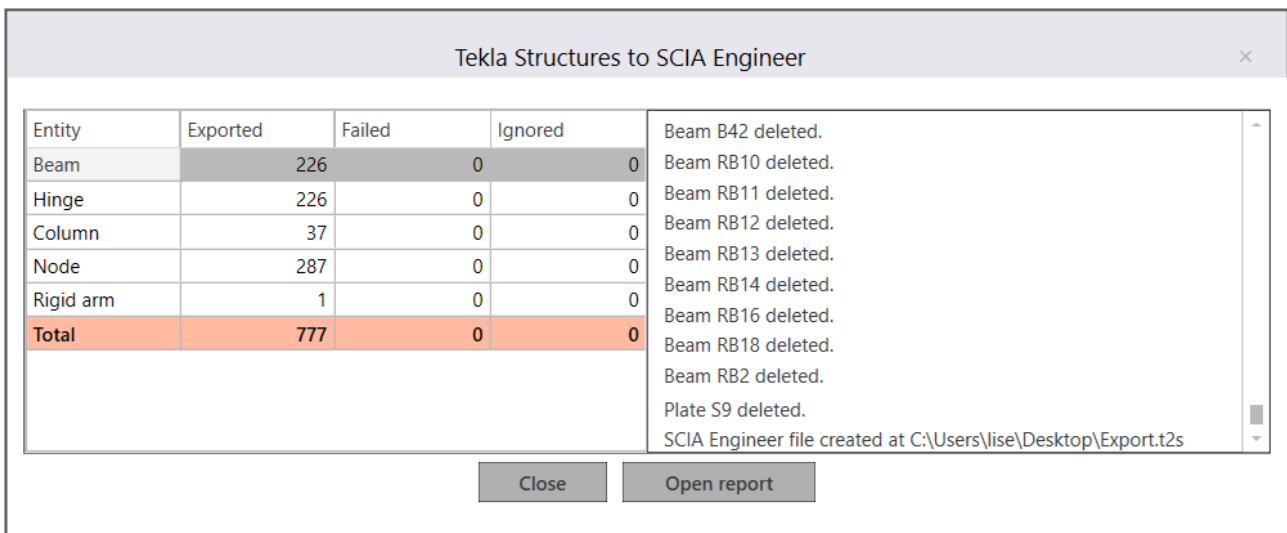

The dialog box titled "Tekla Structures to SCIA Engineer" displays a summary table and a log of actions.

Entity	Exported	Failed	Ignored
Beam	226	0	0
Hinge	226	0	0
Column	37	0	0
Node	287	0	0
Rigid arm	1	0	0
Total	777	0	0

The log on the right lists the following actions:

- Beam B42 deleted.
- Beam RB10 deleted.
- Beam RB11 deleted.
- Beam RB12 deleted.
- Beam RB13 deleted.
- Beam RB14 deleted.
- Beam RB16 deleted.
- Beam RB18 deleted.
- Beam RB2 deleted.
- Plate S9 deleted.

At the bottom of the dialog are "Close" and "Open report" buttons.

You can open the report after export, with the button on the bottom. It looks like this:

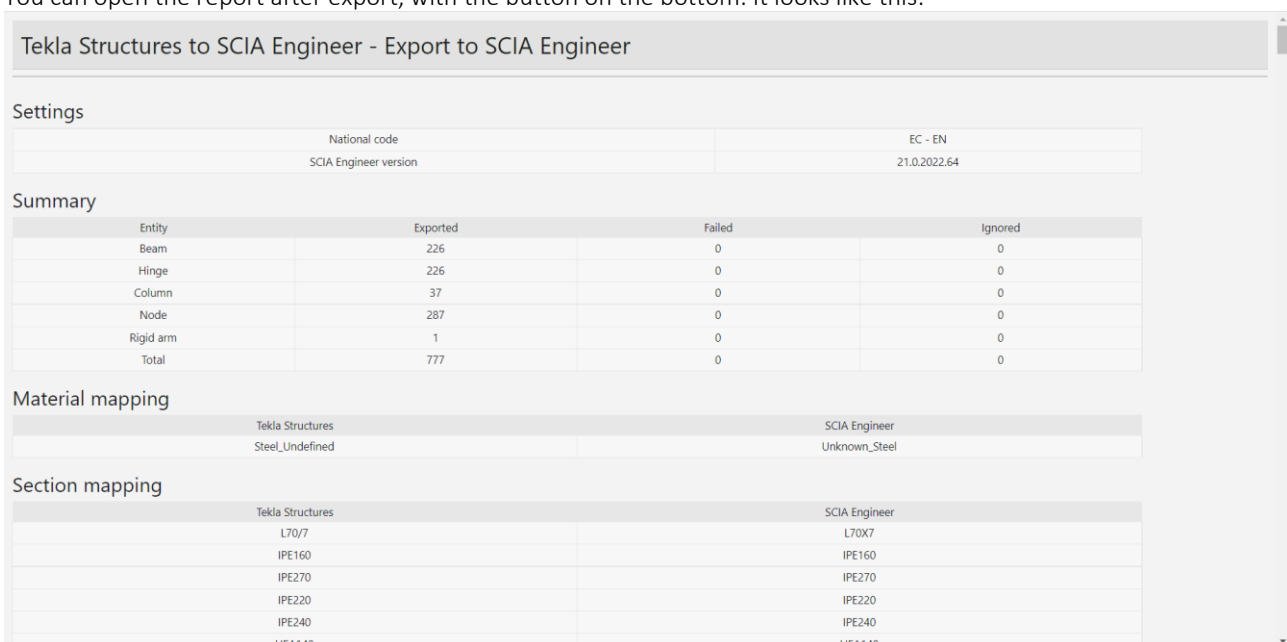

The report titled "Tekla Structures to SCIA Engineer - Export to SCIA Engineer" displays the following sections:

Settings

National code	EC - EN
SCIA Engineer version	21.0.2022.64

Summary

Entity	Exported	Failed	Ignored
Beam	226	0	0
Hinge	226	0	0
Column	37	0	0
Node	287	0	0
Rigid arm	1	0	0
Total	777	0	0

Material mapping

Tekla Structures	SCIA Engineer
Steel_Undefined	Unknown_Steel

Section mapping

Tekla Structures	SCIA Engineer
L70/7	L70X7
IPE160	IPE160
IPE270	IPE270
IPE220	IPE220
IPE240	IPE240
HEA140	HEA140

The log file will also be saved automatically in the job location in the folder ..\SCIA Engineer\Reports. It can be opened in a browser any time to review the transfer.

4.3.3. Opening the model in SCIA Engineer

Using the 'Direct exchange' mode of transfer will open the model directly in SCIA Engineer upon export. SCIA Engineer does not need to be open before starting the export.

There are two options for opening a t2s-file in SCIA, 'Open from' and 'Update from'. The first one will start a new SCIA Engineer project to open the file, the second one will use the project that is already open, and apply the changes made in Tekla while keeping any additional information that might be in the SCIA project, like load cases and combinations, supports etc.

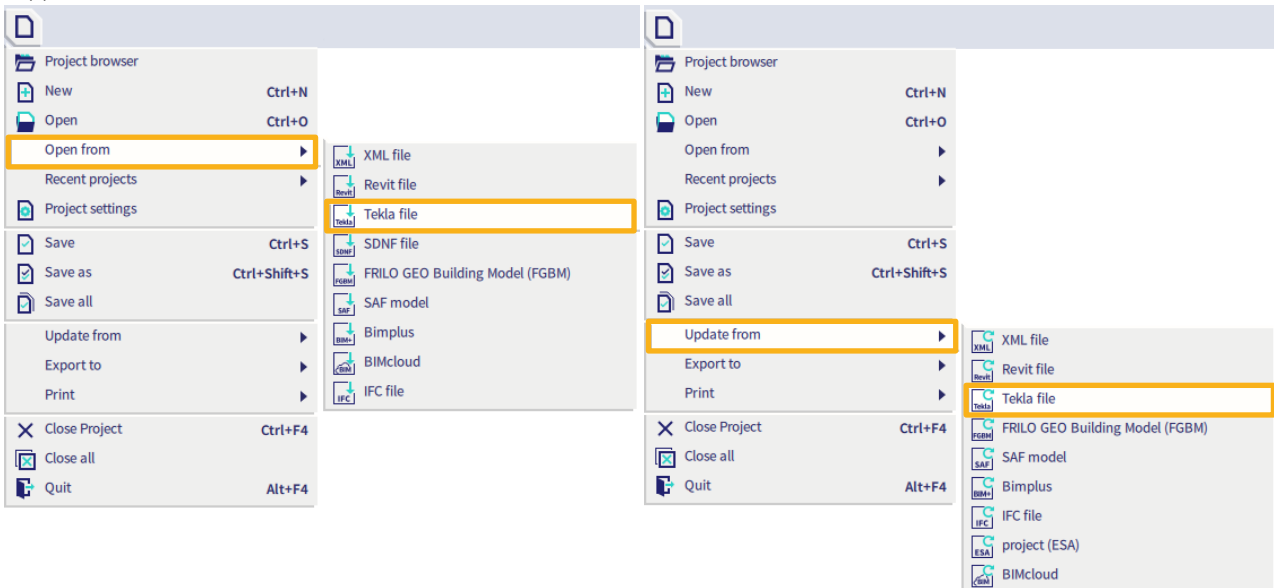

In both cases, a dialog will open, asking you to select the t2s-file.

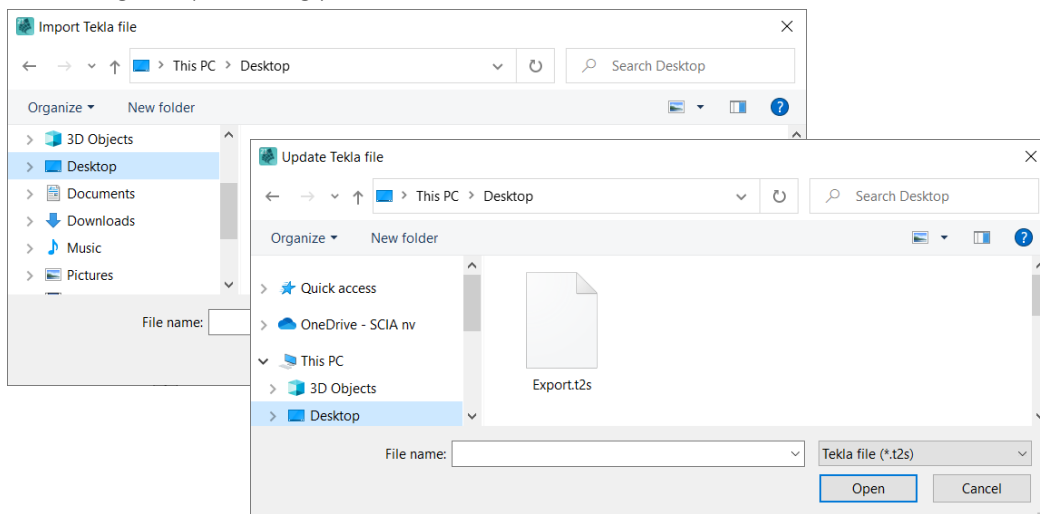

The code that was selected for the export will be shown next. It can be changed with the 'Add' button, or you can just continue using the 'Close' button.

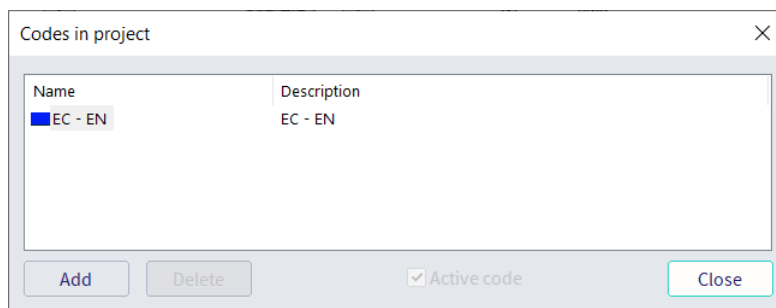

The model will now be shown in SCIA.

4.4. Exchange from SCIA to Tekla

4.4.1. Exporting the model to Tekla Structures

For the 'Direct exchange' mode of transfer, a model should be opened in SCIA Engineer. No other action is required from SCIA side.

For the 'File exchange' mode of transfer, you can export a s2t-file from the menu:

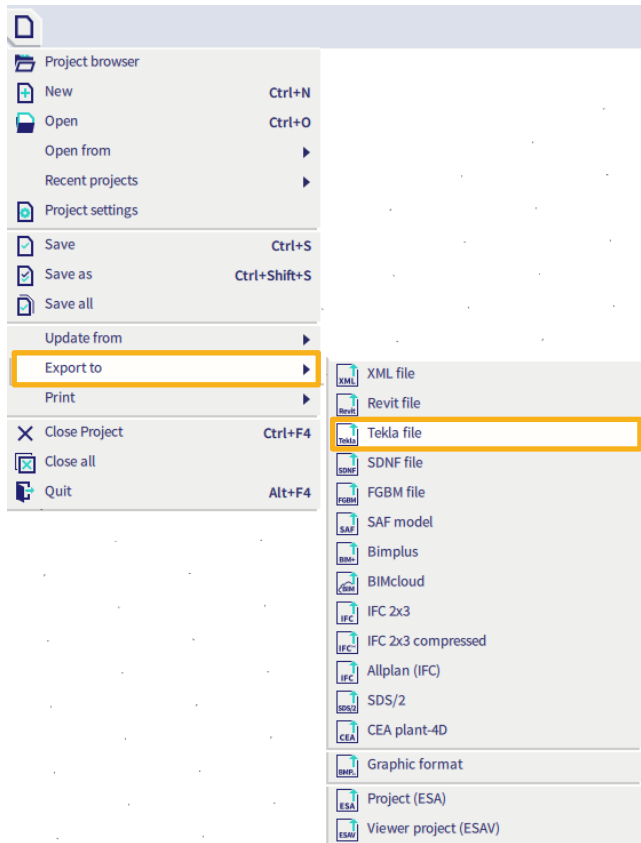

A dialog will be opened to choose a file location to save the file.

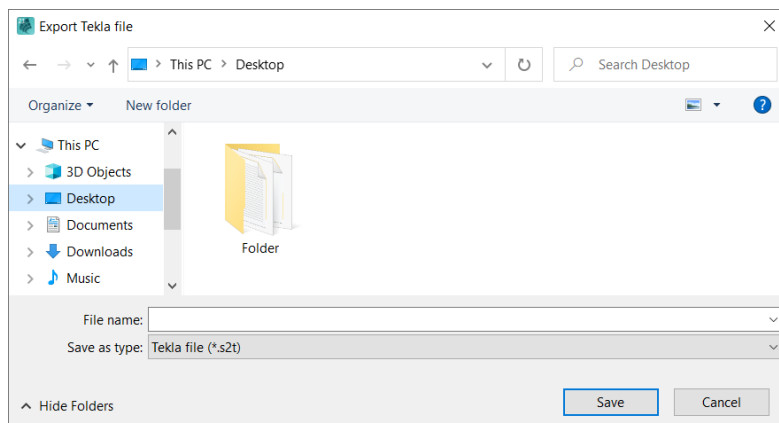

4.4.2. Opening the model in Tekla Structures

You can now open the model in Tekla Structures using the SCIA Engineer application.

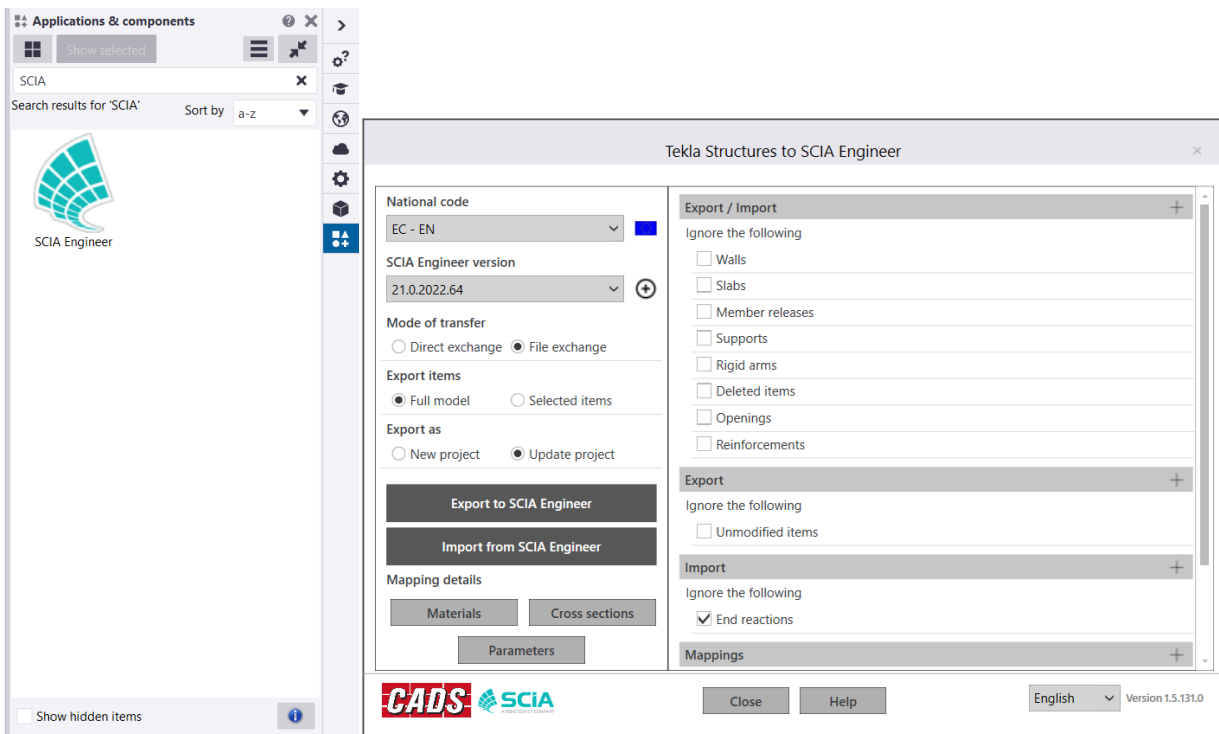

Using the 'Direct exchange' mode of transfer will open the model that is open and active in SCIA Engineer. Using the 'File exchange' mode of transfer will prompt a dialog asking to select the s2t-file to be opened.

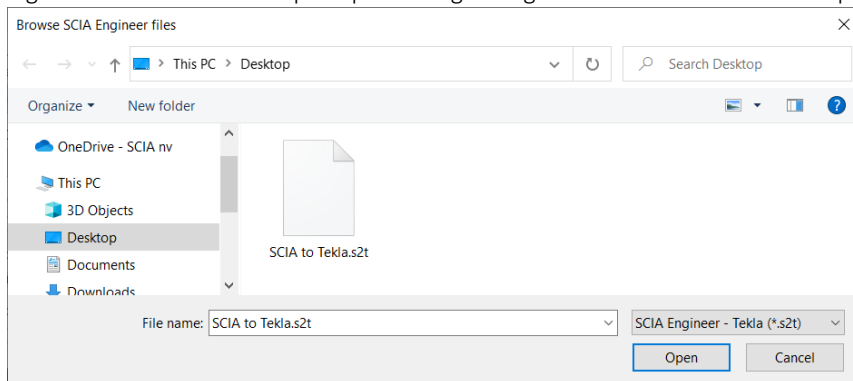

The next steps are very similar to the workflow for exporting a model from Tekla. Make sure to check the options in the main dialog on the right and select the mappings in the upcoming dialogs.

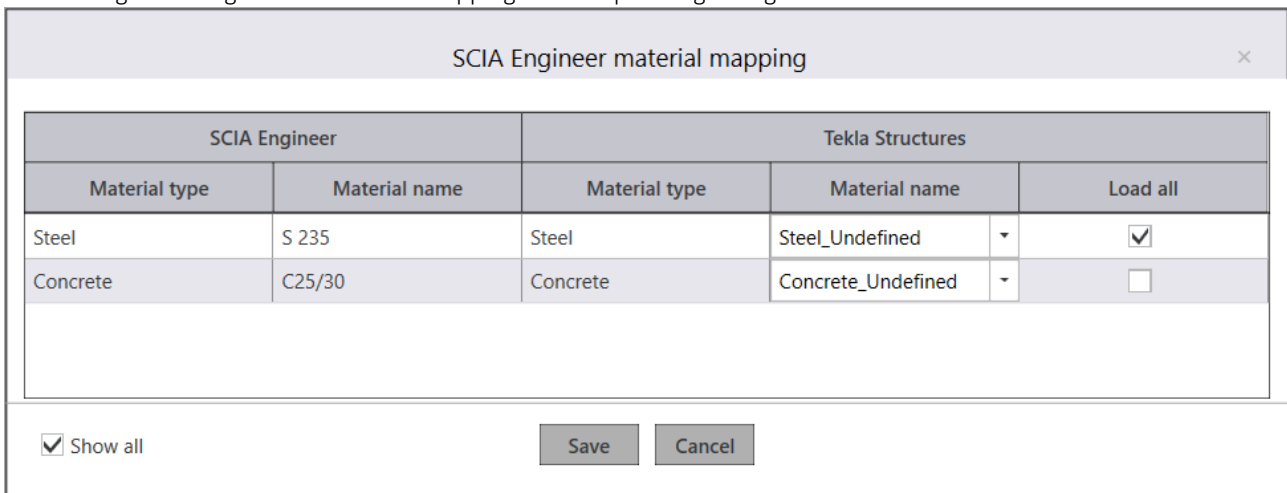

SCIA Engineer section mapping				
SCIA Engineer		Tekla Structures		
Section name	Material type	Profile shape	Section name	Load all
Rectangle	Concrete	Rectangle	BL200*200	<input type="checkbox"/>
IPE240	Steel	I Section	IPE240	<input type="checkbox"/>
L80X8	Steel	L Section	UAP175	<input type="checkbox"/>

Show all

In case you are not satisfied with the available sections for mapping, you can download additional cross-sections from the Tekla warehouse, like the following set:

<https://warehouse.tekla.com/#/catalog/details/131d7061-666b-4592-8812-c427dbdf4bb1>

The log shows the steps taken in the import process. Any failed items will be shown in red.

Tekla Structures to SCIA Engineer				
Entity	Imported	Failed	Ignored	
Column	4	0	0	Beam B7 deleted.
Beam	4	0	0	Column B4 deleted.
Contour plate	1	0	0	Column B3 deleted.
Nodal support	4	0	0	Column B2 deleted.
Total	13	0	0	Column B1 deleted.
				Contour plate S1 created.
				Contour plate S1 deleted.
				Analysis properties are updated for member S1.
				Analysis properties are updated for member B1.
				Analysis properties are updated for member B2.
				Analysis properties are updated for member B3.
				Analysis properties are updated for member B4.
				Analysis properties are updated for member B5.
				Analysis properties are updated for member B6.
				Analysis properties are updated for member B7.
				Analysis properties are updated for member B8.
				Support conditions are modified for node 7
				Support conditions are modified for node 9
				Support conditions are modified for node 13
				Support conditions are modified for node 11
				Support conditions are modified for node 13
				Support conditions are modified for node 11
				Support conditions are modified for node 9
				Support conditions are modified for node 7

After closing this dialog, the model is shown in Tekla.