



## BASIC CONCEPT TRAINING

SCiA Engineer 24

All information in this document is subject to modification without prior notice. No part of this manual may be reproduced, stored in a database or retrieval system or published, in any form or in any way, electronically, mechanically, by print, photo print, microfilm or any other means without prior written permission from the publisher. SCIA is not responsible for any direct or indirect damage because of imperfections in the documentation and/or the software.

© Copyright 2024 SCIA nv. All rights reserved.

# Table of contents

<b>Chapter 1: Getting started .....</b>	<b>7</b>
<b>1.1. Graphical user interface .....</b>	<b>7</b>
1.1.1. Graphical window.....	7
1.1.2. Main menu .....	7
1.1.3. SCIA Spotlight.....	11
1.1.4. Status bar.....	13
1.1.5. Property panel.....	15
1.1.6. Viewbar (with Navicube) .....	16
1.1.7. Input panel .....	18
1.1.8. Process toolbar .....	18
1.1.9. Marking Menu .....	20
<b>1.2. Global UI settings.....</b>	<b>22</b>
1.2.1. Environment.....	22
1.2.2. Other .....	23
<b>1.3. Project settings .....</b>	<b>24</b>
1.3.1. Basic data .....	24
1.3.2. Functionality .....	25
1.3.3. Actions .....	25
1.3.4. Unit Set .....	26
1.3.5. Protection.....	26
<b>Chapter 2: Modelling .....</b>	<b>27</b>
<b>2.1. Line grid .....</b>	<b>27</b>
<b>2.2. Views, visibility and layers.....</b>	<b>29</b>
2.2.1. Views .....	29
2.2.2. Visibility .....	29
2.2.3. Layers .....	30
<b>2.3. Selection .....</b>	<b>30</b>
<b>2.4. View settings for all entities.....</b>	<b>31</b>
<b>2.5. Material database .....</b>	<b>31</b>
<b>2.6. Cross-sections .....</b>	<b>32</b>
<b>2.7. 1D elements .....</b>	<b>34</b>
<b>2.8. 2D elements .....</b>	<b>35</b>
<b>2.9. Load panels .....</b>	<b>38</b>
<b>2.10. Supports .....</b>	<b>40</b>
<b>2.11. Catalog blocks .....</b>	<b>42</b>
<b>2.12. Haunch .....</b>	<b>43</b>
<b>2.13. Hinges .....</b>	<b>45</b>
<b>2.14. Beam non-linearity.....</b>	<b>46</b>
<b>2.15. Subsoil .....</b>	<b>47</b>
<b>2.16. Modify shape .....</b>	<b>48</b>
<b>2.17. Connect members.....</b>	<b>50</b>
<b>2.18. Check structure data .....</b>	<b>51</b>
<b>2.19. Modification commands.....</b>	<b>52</b>
2.19.1. Copy.....	52
2.19.2. Multicopy .....	52
2.19.3. Mirror.....	53
2.19.4. Break in defined points.....	53
<b>2.20. Input table.....</b>	<b>54</b>
<b>Chapter 3: Loads .....</b>	<b>55</b>
<b>3.1. Load cases.....</b>	<b>55</b>
<b>3.2. Load groups .....</b>	<b>55</b>
3.2.1. Permanent load group .....	55
3.2.2. Variable load group.....	56
<b>3.3. Combinations .....</b>	<b>56</b>
3.3.1. Linear combinations .....	57
3.3.2. Envelope combinations .....	58
3.3.3. Eurocode combinations .....	59
<b>3.4. Nonlinear combinations .....</b>	<b>61</b>
<b>3.5. Result class .....</b>	<b>62</b>
<b>3.6. Point force .....</b>	<b>63</b>
3.6.1. Point force in node .....	63
3.6.2. Point force on beam.....	64

3.6.3. Free point force .....	65
<b>3.7. Line force .....</b>	<b>68</b>
<b>3.8. Surface load .....</b>	<b>68</b>
<b>Chapter 4: Calculation .....</b>	<b>69</b>
<b>4.1. Mesh .....</b>	<b>69</b>
<b>4.2. Calculation / Solver .....</b>	<b>70</b>
<b>Chapter 5: Results .....</b>	<b>71</b>
<b>5.1. Requesting results .....</b>	<b>71</b>
5.1.1. Calculation protocol .....	71
5.1.2. Nodal displacement .....	72
5.1.3. 3D Results .....	72
5.1.4. Results per component .....	72
5.1.5. Bill of material .....	73
5.1.6. Thickness of slabs .....	73
5.1.7. Setting the properties menu .....	74
<b>5.2. Results table .....</b>	<b>80</b>
<b>5.3. Results preview .....</b>	<b>81</b>
<b>5.4. Section on 2D member .....</b>	<b>81</b>
<b>5.5. Averaging strip .....</b>	<b>82</b>
<b>5.6. Integration strip / integration member .....</b>	<b>85</b>
<b>Chapter 6: Steel design .....</b>	<b>87</b>
<b>6.1. Steel setup .....</b>	<b>87</b>
<b>6.2. Buckling settings .....</b>	<b>88</b>
6.2.1. Default buckling calculation .....	88
6.2.2. Assign buckling groups .....	90
<b>6.3. Steel member data .....</b>	<b>92</b>
6.3.1. LTB restraints .....	92
6.3.2. Steel stiffeners .....	93
6.3.3. Sheeting .....	93
<b>6.4. ULS Check .....</b>	<b>94</b>
6.4.1. Graphic output .....	95
6.4.2. Preview .....	96
6.4.3. Table output .....	97
<b>6.5. SLS Check .....</b>	<b>98</b>
<b>6.6. General autodesign .....</b>	<b>99</b>
<b>6.7. Connection check .....</b>	<b>103</b>
<b>Chapter 7: Concrete design .....</b>	<b>107</b>
<b>7.1. Concrete setup .....</b>	<b>107</b>
<b>7.2. Recalculated internal forces .....</b>	<b>107</b>
<b>7.3. Provided reinforcement .....</b>	<b>110</b>
<b>7.4. Required reinforcement .....</b>	<b>112</b>
7.4.1. 1D members .....	112
7.4.2. 2D members .....	113
<b>7.5. User reinforcement .....</b>	<b>115</b>
7.5.1. 1D members .....	115
7.5.2. 2D members .....	120
<b>7.6. 1D ULS &amp; SLS checks .....</b>	<b>121</b>
7.6.1. Capacity response .....	121
7.6.2. Capacity Diagram .....	121
7.6.3. Shear + Torsion .....	122
7.6.4. Stress limitation .....	122
7.6.5. Crack width .....	123
7.6.6. Deflection .....	124
<b>7.7. 2D Crack width check .....</b>	<b>125</b>
7.7.1. Type of used reinforcement .....	125
<b>7.8. Punching check .....</b>	<b>127</b>
<b>7.9. Code dependent deformations .....</b>	<b>129</b>
<b>Chapter 8: Engineering report .....</b>	<b>131</b>
<b>8.1. General interface .....</b>	<b>131</b>
<b>8.2. General page layout .....</b>	<b>132</b>
8.2.1. Page layout .....	132
8.2.2. Page format and page break .....	133
8.2.3. Header and footer .....	134



---

8.2.4.	Chapter .....	134
8.2.5.	Formatted text .....	135
<b>8.3.</b>	<b>Adding pictures .....</b>	<b>136</b>
8.3.1.	Screenshot or live pictures .....	136
8.3.2.	Inbox .....	137
8.3.3.	Picture gallery .....	138
8.3.4.	Paperspace gallery .....	139
8.3.5.	Generating result pictures .....	139
8.3.6.	Report template .....	142
8.3.7.	Export .....	143
8.3.8.	Print .....	143



## Chapter 1: Getting started

This chapter will provide you a general overview of SCIA Engineer. It contains the general interface, the options, and the project data.

### 1.1. Graphical user interface

The graphical user interface (GUI) of SCIA Engineer contains the following elements:

Graphical window, Main menu, SCIA Spotlight, Status bar, Properties panel, Viewbar (with Navicube), Input panel and the Process toolbar.

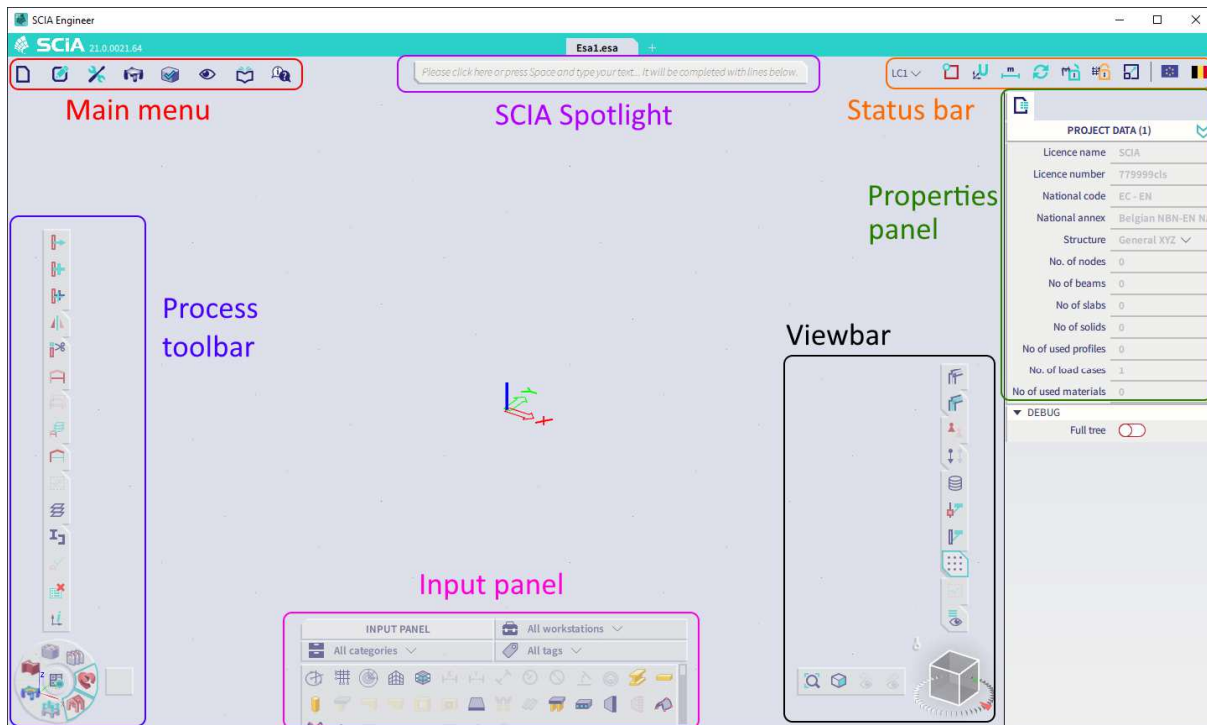

#### 1.1.1. Graphical window

The Graphical window takes the entire screen. The other elements of the GUI are shown on top of the Graphical window. Some of these elements have a fixed location on the screen and others can be moved to any location.

#### 1.1.2. Main menu

The Main menu is located at the top left corner of the screen (fixed location).

This menu contains all **action**-related functions and is closely related to the Input panel (that contains all input-related functions).

For every function in the Main menu, it is possible to assign a shortcut by clicking at the right side and inputting the shortcut.



### 1.1.2.1. File

With the File menu you can manage your project files (creating, opening, saving, importing, updating exporting, closing), access the project settings, and exit SCIA Engineer.

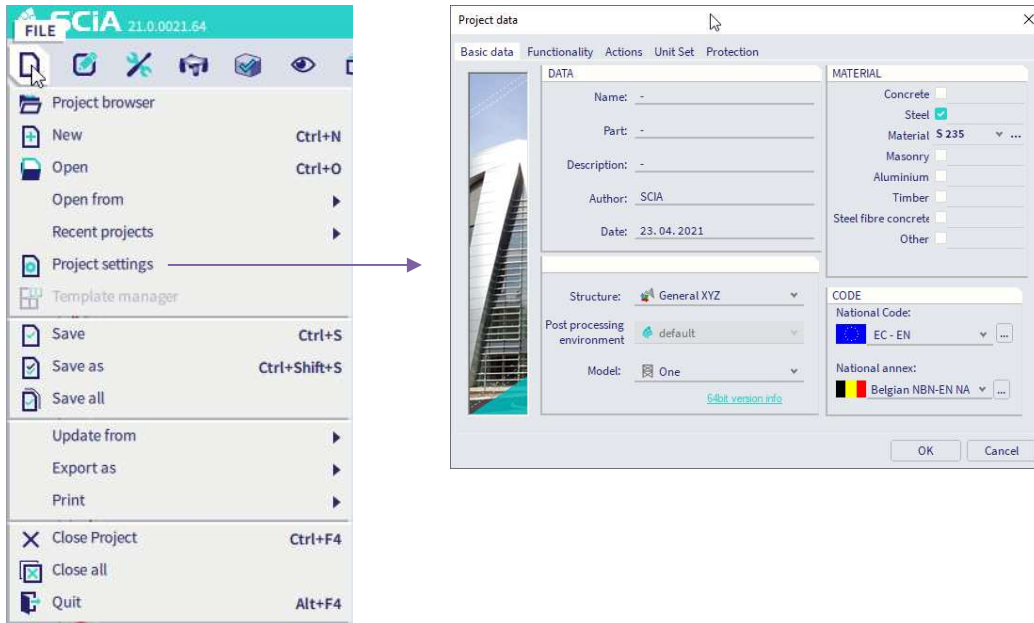

### 1.1.2.2. Edit

With the Edit menu you can modify (move, copy, rotate, ...) objects, properties, add data and metadata. You can edit polylines, curves, solids and calculate member end-cuts.

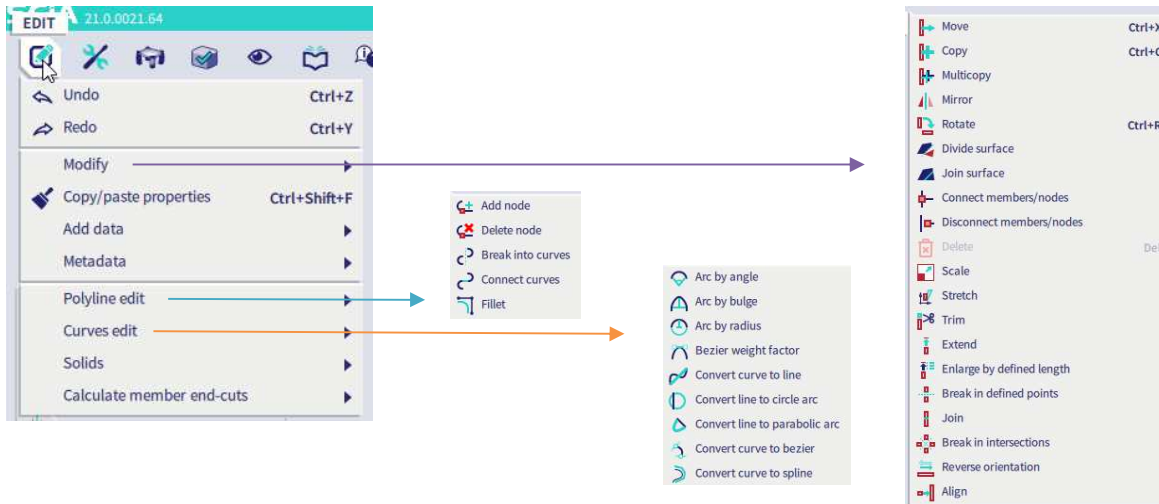

### 1.1.2.3. Tools

The Tools menu contains a variety of tools, like the calculation & mesh, tools for making selections, the BIM toolbox, coordinates info, tools for creating and filling the Engineering report, ...

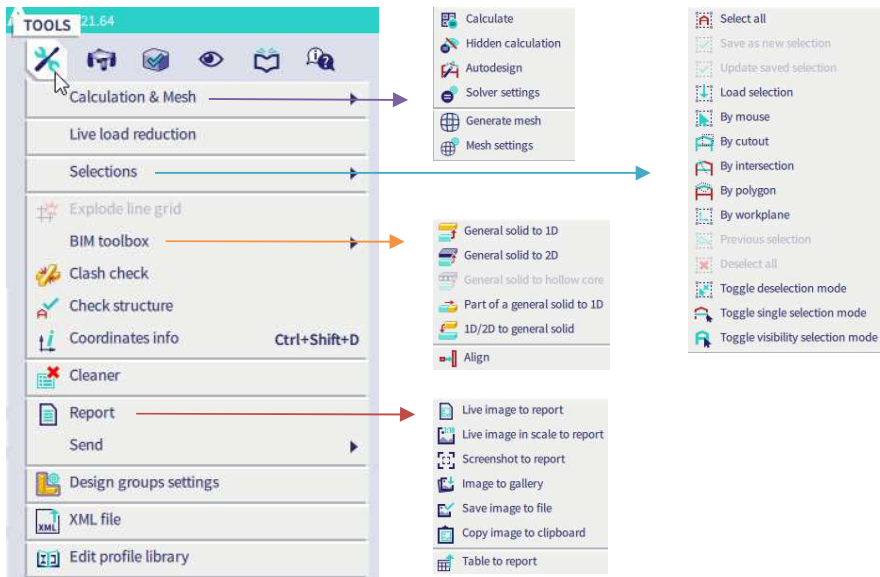

### 1.1.2.4. Results

With the results menu you can access the (solver) results that are available after the calculation of the structure.

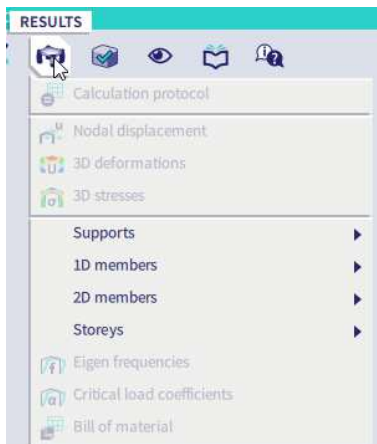

### 1.1.2.5. Design

The design menu offers all features for the design and check of steel members and connections, aluminium members, timber members, concrete 1D and 2D elements, composite elements, ...

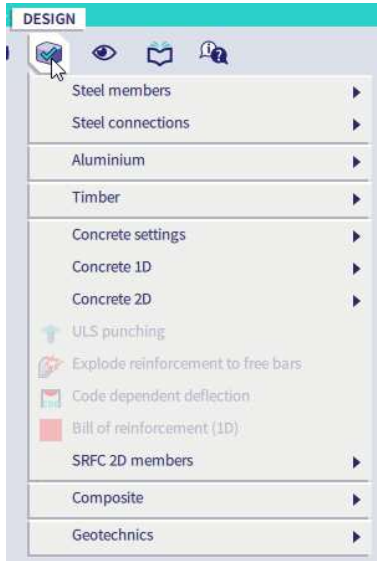

### 1.1.2.6. View

In the View menu, we discover all features for the Visibility (f.k.a. Activity) settings, the Clipping box, settings for the UI, colour & line settings, the configuration of the line and dot grids, ...

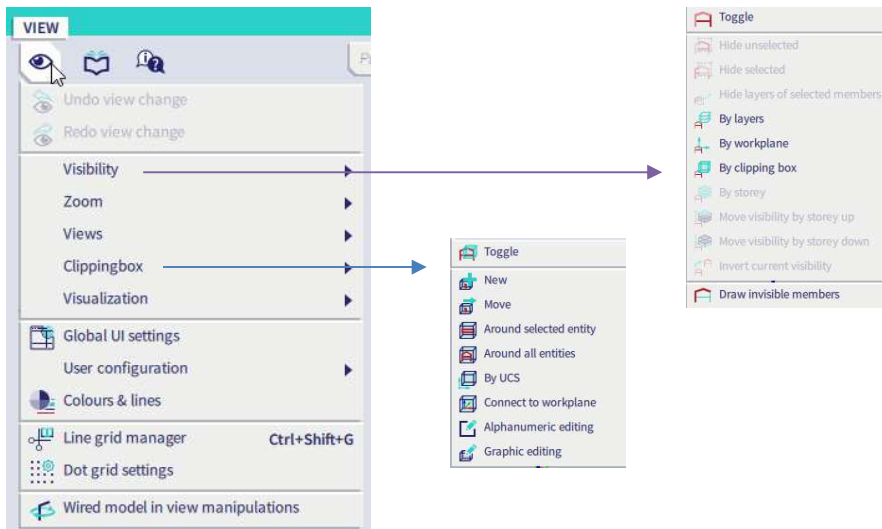

### 1.1.2.7. Libraries

The Libraries menu is very important and extensive because it contains the links to all libraries that are linked to SCIA Engineer. When working in a project, then the required library items are always copied to and saved with that project.

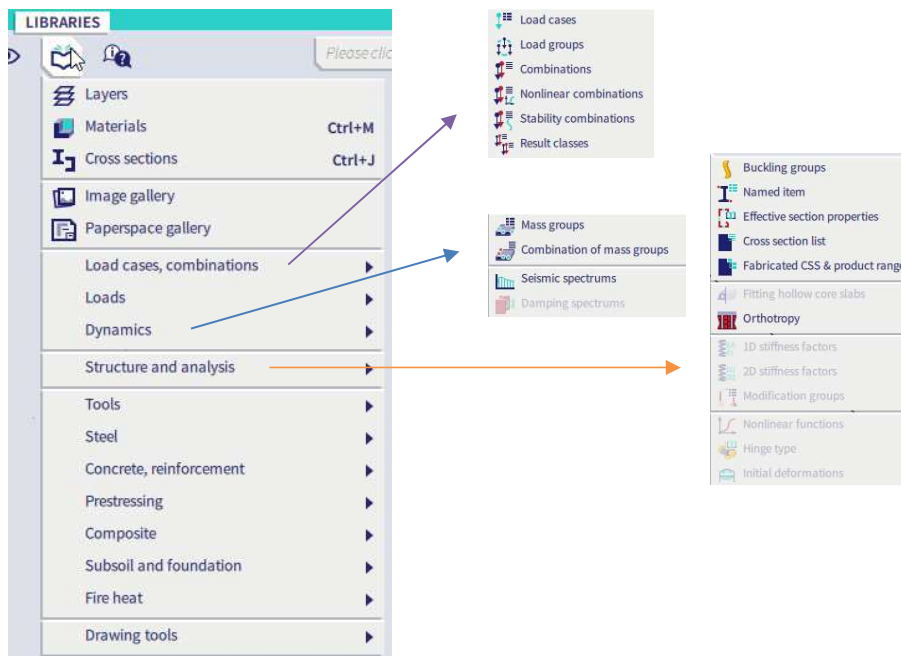

### 1.1.2.8. Help

The Help menu offers a link to the onboarding tutorials (concrete, steel, ...) and a direct link to the online help pages of SCIA Engineer. With the 'Share your screen...' -feature you can share your screen with our support representatives.



### 1.1.3. SCIA Spotlight

The SCIA Spotlight is located at the top middle part of the screen (fixed location).





The SCIA Spotlight has several functions:

### 1.1.3.1. Searching for a specific command



In the SCIA Spotlight there are 2 buttons: you can search the online help for the inputted search string, and you can clear the inputted search string.



### 1.1.3.2. Adding a shortcut to a specific command

By clicking at the right side of the window, a blue line appears at the bottom and this allows us to define a shortcut for this specific command.



There are 2 buttons available for each command: you can search the online help to see all available information about this command.

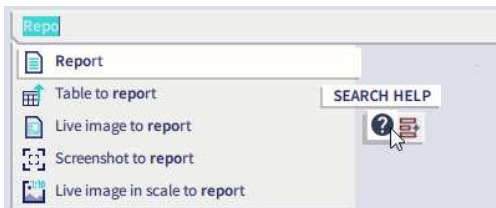

You can also use the Show Me button to show where this command is in the Main Menu. In this case the Main Menu it automatically opened, and the command is highlighted.

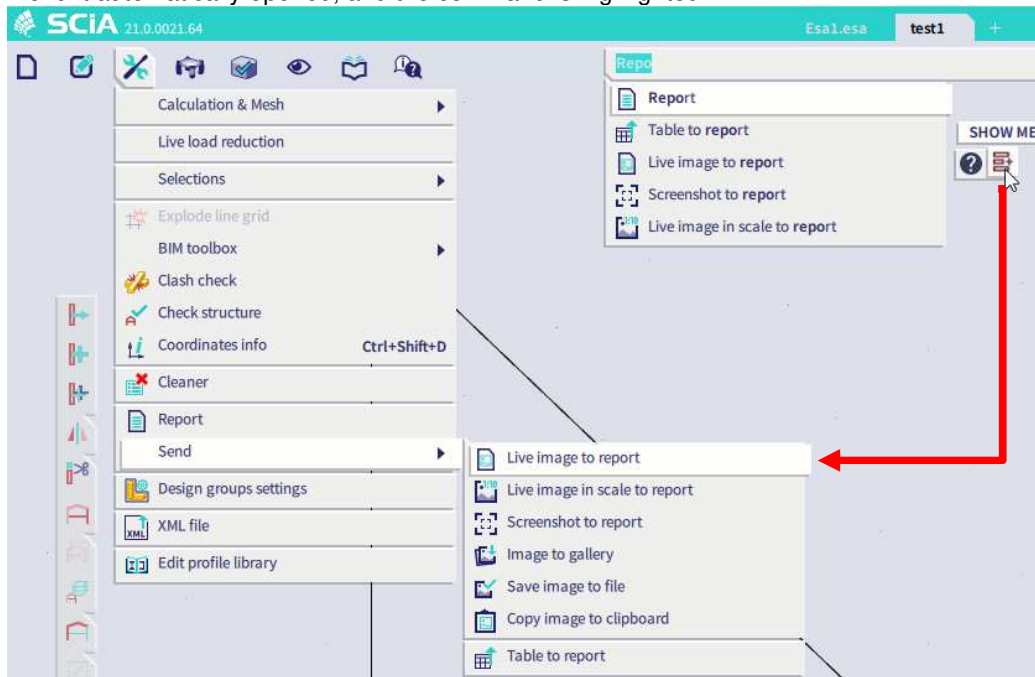

### 1.1.3.3. Input field

The information in the SCIA Spotlight will guide you through the different steps when executing a command. It also offers a place to input data (like e.g., the X, Y and Z coordinate of a point, ...) and it offers contextual menus (like e.g., for changing the line type from a straight shape to a parabolic shape, ...)

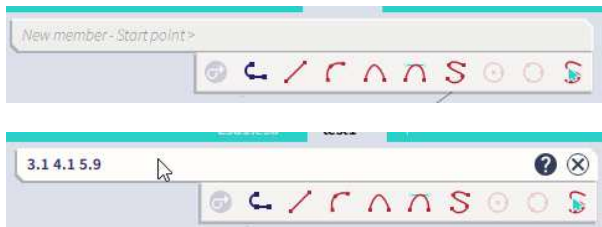

### 1.1.4. Status bar

The Status bar is located at the top right corner of the screen (fixed location).



It contains items to select the Active load case selection, or to configure the snap setting, the User coordinate system tools, the Units, ...

### Active load case selection



For easy overview and switching.

### Snap settings

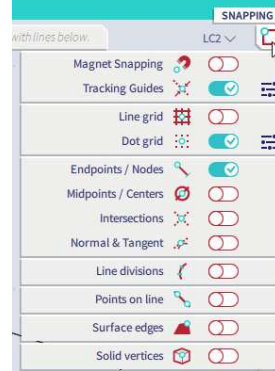

### User coordinate system

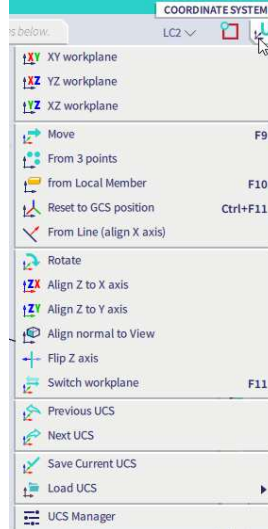

### Units

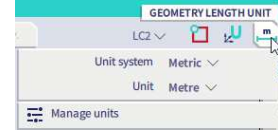

The Autorefresh toggle can be used to automatically draw results when a result property is changed.



The Results lock toggle can be used to 'lock' the current results – the results will not be deleted when data (that affect the result) in the project is changed.



The Grid mode toggle can be used to enable 'editing' the grids. A grid can normally (grid mode = OFF) only be used as snapping points. But, when you want to edit the grid, then the Grid mode must be toggled to ON.



The scale settings for input data (e.g., size of support symbol, arrow length of load, ...) and for result data (e.g., size of results diagram) can be modified.

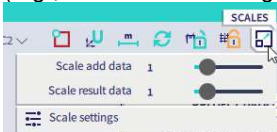

The settings for the National code and National Annex can be set.



### 1.1.5. Property panel

The Property panel is located – by default – at the right side of the screen (but can be moved to any location).

The property panel displays all properties of the selection. You can easily check or modify the properties by using this window.

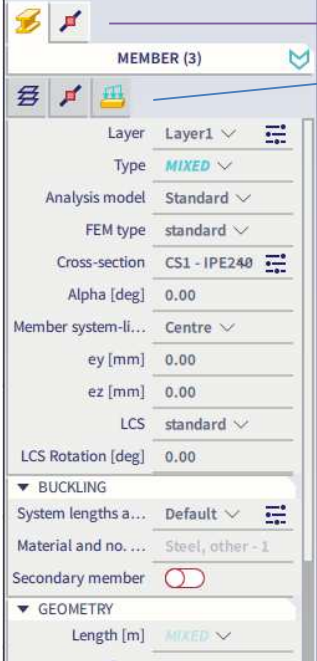

Icons show the list of items in the selection.

Icons show the list of 'related' items to the selected items.

Click on an icon to show the properties of that entity.

Drag icon onto the Bin to unselect / remove these elements from the selection

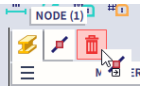

The properties of the 'related' items are visible and can be modified.

Right-clicking on a property allows to modify the current selection. We can **isolate** the entities with only this property from the entire selection, or we can **expand** the current selection and add all entities with this property, or we can **subtract** all entities with this property from the entire selection.

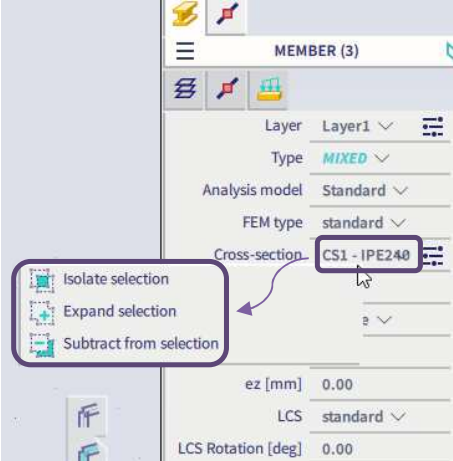

It is possible to reduce / increase the number of properties that are shown for a particular item. The list of properties can be shown in **basic mode** (with only a few properties visible) or **advanced mode** (with all properties visible).

By clicking on the chevron at the right top side of the Properties Panel, you can switch between these modes.

### Advanced mode

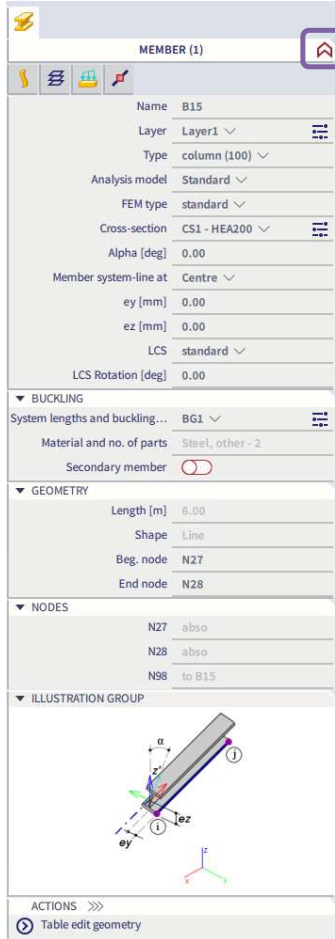

### Basic mode

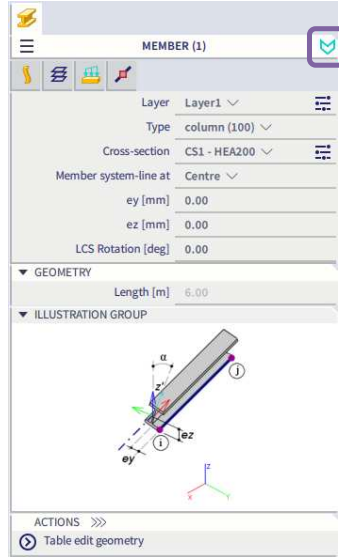

### 1.1.6. Viewbar (with Navicube)

The Viewbar and Navicube are located at the bottom right corner of the screen (fixed location).

The shortcuts for view settings enables the quick adjustment of the view parameters. The following pictures provide a graphical representation of all the options.

#### Volumes OFF or ON

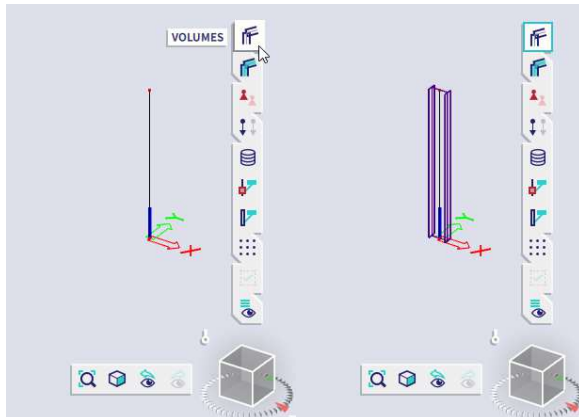

#### Rendering ON -- Transparency OFF and ON

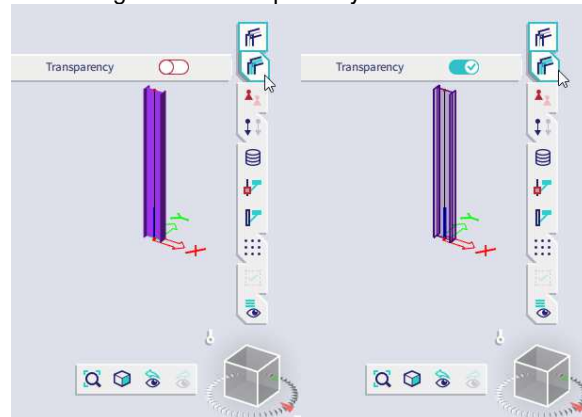

Support symbols OFF or ON

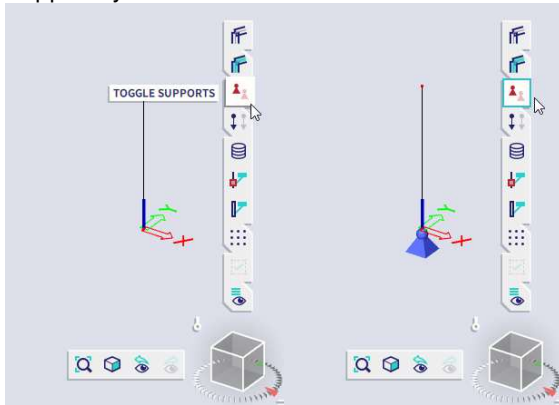

Loadcase selection – Load symbols OFF or ON

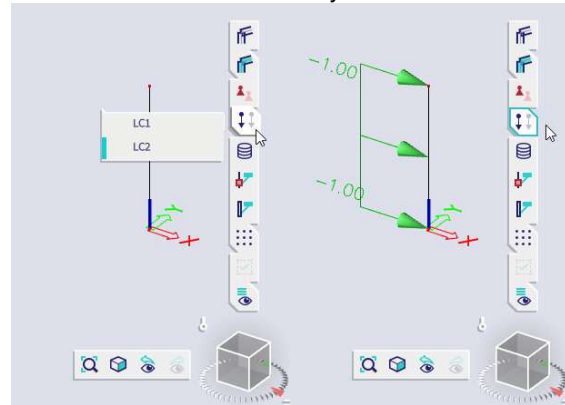

Other Model Data symbols OFF or ON

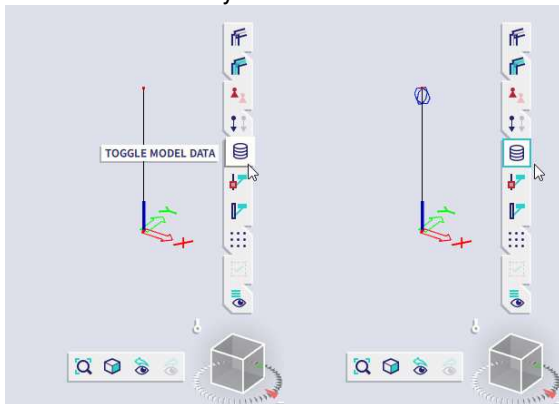

Node labels OFF or ON

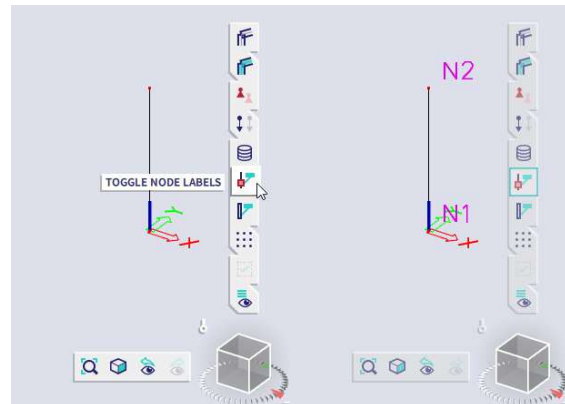

Beam labels OFF or ON

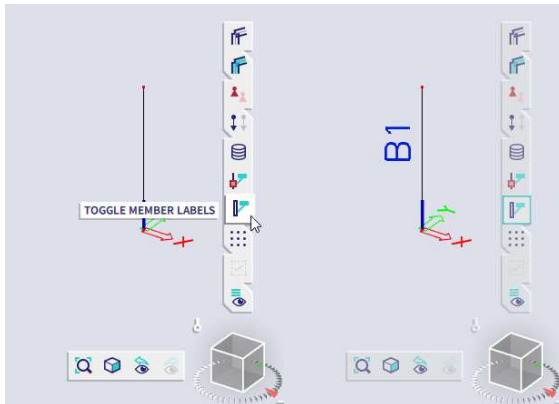

Dot and Line grids OFF or ON

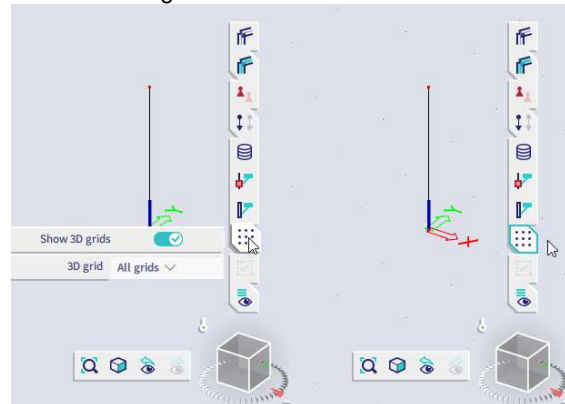

Apply to selection OFF or ON

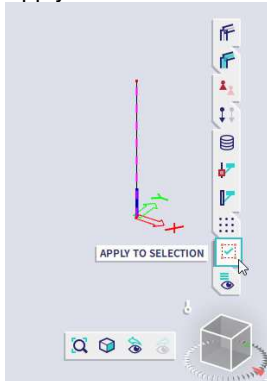

More options button

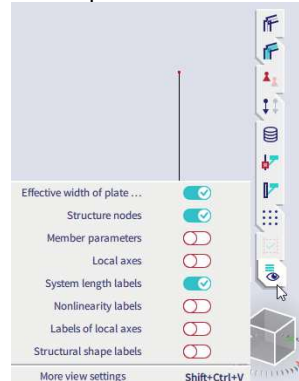

With this setting ON, then the view-setting changes are only applied to the elements in the selection.

This allows a more in-depth configuration of the view settings.

### 1.1.7. Input panel

The Input panel is located – by default – at the bottom middle of the screen (but can be moved to any location).

The Input panel is the core element that is used for inputting data in the project.

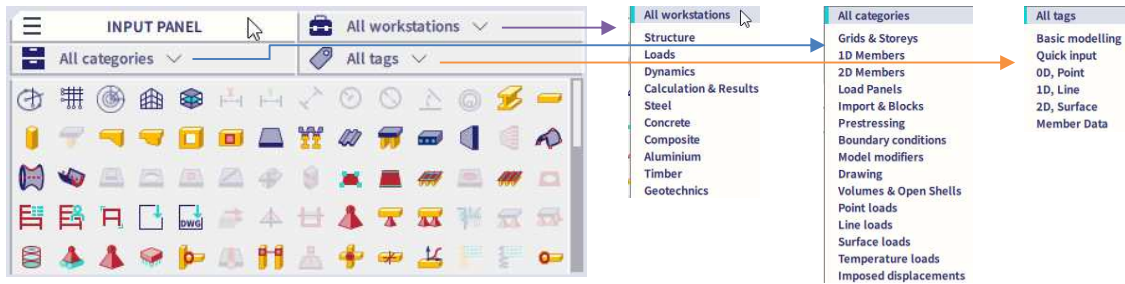

There are several filtering options available to filter out just these options that you need. You can filter (simultaneously) on workstation, on category and on tag.

Filter on Workstation = Loads



Then, filter on Category = Line Loads

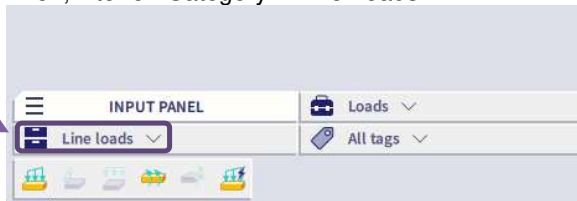

With the hamburger menu, it is possible to configure the Input Panel: with the Icon mode toggle you can switch between icons and icons + descriptions, and with the Show category headers toggle you can switch on or off category headers for the icons.



### 1.1.8. Process toolbar

The Process toolbar is located – by default – at the bottom left corner of the screen (but can be moved to any location).

The process toolbar is the main element on the screen that allows you to fully personalise the graphical user interface of SCIA Engineer.

It is composed of 'workstations', which represents the logic stages in the normal workflow of entering a project.



The icon bars of the horizontal and vertical workstations are shown with user-defined functions.

The active workstations are shown in the doughnut. **Left-clicking** on a button activates the icon bar of the horizontal workstation. **Ctrl+Left-clicking** on a button activates the icon bar of the vertical workstation.

In the configuration menu, you can activate multiple workstations (max simultaneous = 8)

Structure		<input checked="" type="checkbox"/>
Construction stages		<input type="checkbox"/>
Loads		<input checked="" type="checkbox"/>
Results		<input checked="" type="checkbox"/>
Steel		<input checked="" type="checkbox"/>
Concrete		<input type="checkbox"/>
Composite		<input type="checkbox"/>
Aluminium		<input type="checkbox"/>
Timber		<input type="checkbox"/>
Reports		<input checked="" type="checkbox"/>
My Workstation		<input checked="" type="checkbox"/>

The little icon on the right side swaps the icon bars of the horizontal and vertical workstation

With the little icon on the left side you can drag the process toolbar to another position

In the centre of the doughnut, we have the button to start the calculation. Their icons will appear in the doughnut.

### 1.1.8.1. Adding an item to the icon bar of a workstation

Adding an item to the icon bar of a workstation can be done by a Drag-and-Drop operation of a feature from the **Main Menu** or from the **SCIA Spotlight**.

Drag and Drop from the SCIA Spotlight

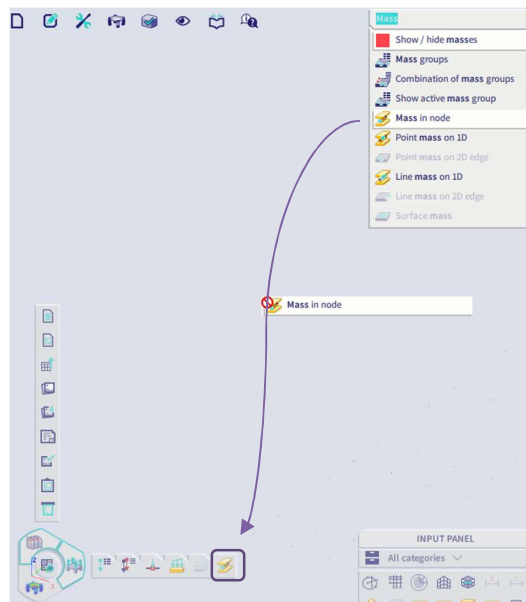

An icon can be dropped...  
...to the right of an existing icon, or



...to the left of an existing icon, or



...on top of an existing icon,



thus creating a stacked icon bar



### 1.1.8.2. Deleting an item from the icon bar of a workstation

Deleting an icon from the icon bar of a workstation, can be done Drag-and-Drop operation of this icon onto the Bin.



### 1.1.8.3. Saving the configuration of the Process Toolbar

The configuration of the Process Toolbar can be saved to a configuration file via **Main Menu → View → User configuration**. This allows you to create multiple configurations (depending on the type of project), or to migrate your settings to another computer, or another version of SCIA Engineer.

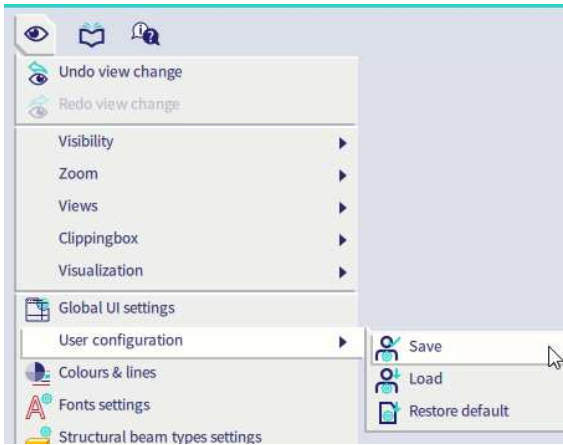

### 1.1.9. Marking Menu

The Marking Menu is an invisible menu which you can call for at any location by holding ALT and clicking on the right mouse button:

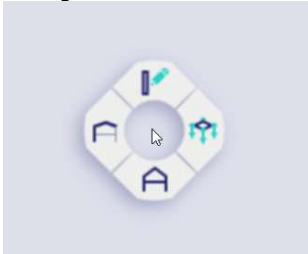

By hovering over the 4 submenus you can access SCIA's most basic functions, we give you an overview of these in the chapters below. A more detailed explanation about these functions can be found further down this manual.

#### 1.1.9.1. Model

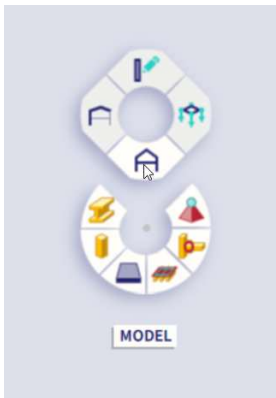

In this submenu you can find the most used functions to built up your model:

- 1D member
- Column
- Plate
- Panel with load to 1D & edges
- Hinge on 1D
- Support in node

### 1.1.9.2. Visibility



In this submenu you can find the most used functions to change the visibility of your model:

- Hide selected
- Hide unselected
- Make layers visible

### 1.1.9.3. Modify



In this submenu you can find the most used functions to modify your model:

- Move
- Copy
- Multicopy
- Break in defined points
- Connect members/nodes
- Disconnect members/nodes

### 1.1.9.4. Load



In this submenu you can find the most used functions to apply loads to your model:

- Point load in node
- Point load on 1D
- Line load on 1D
- Line load on 2d edge
- Surface load on 2D
- Free surface load

## 1.2. Global UI settings

In this chapter the most essential settings in the Global UI settings menu are explained. You can find the Global UI settings menu in **Main Menu** → **View**.

### 1.2.1. Environment

In the Environment tab, you can alter the Rendering and Antialiasing settings.

If the graphics card of your computer is having issues with rendering, the following settings must be decreased.

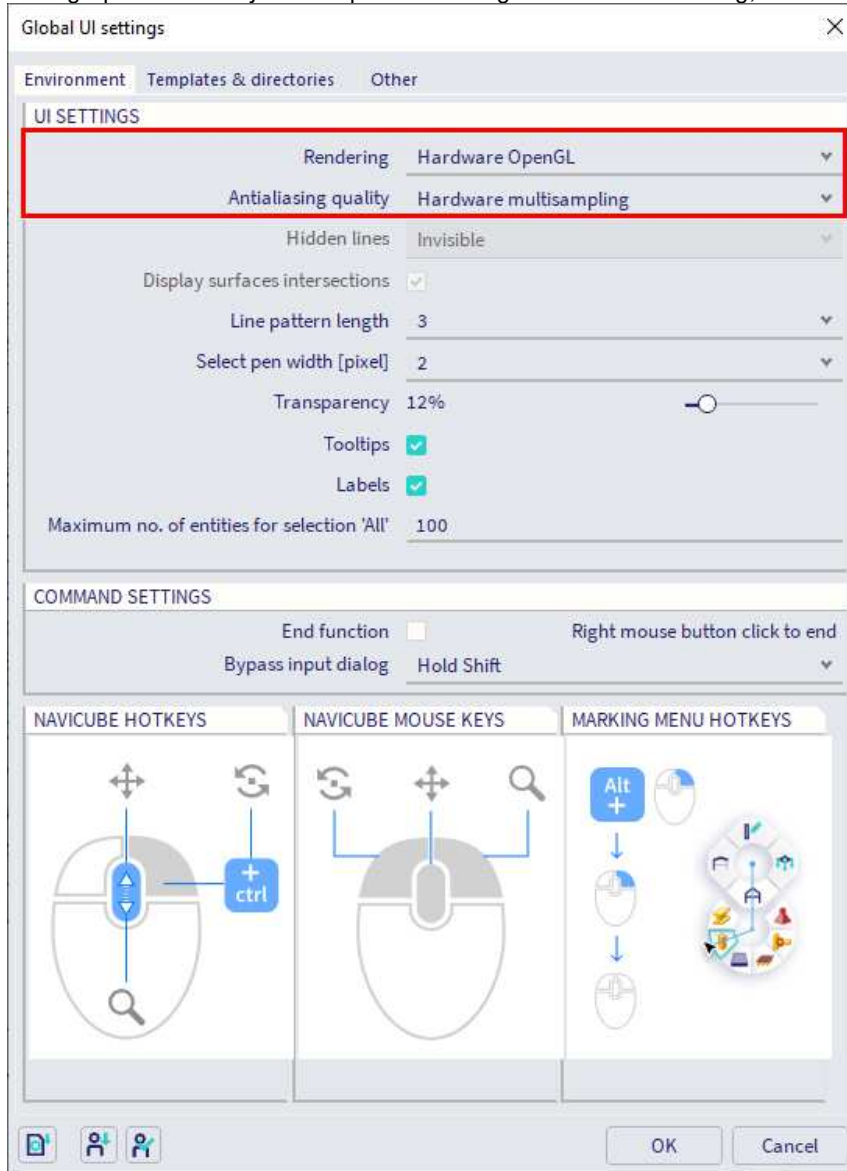

## 1.2.2. Other

In the Other tab, you can select the language that will be used in SCIA Engineer. The workspace (GUI) and the output can have different languages.

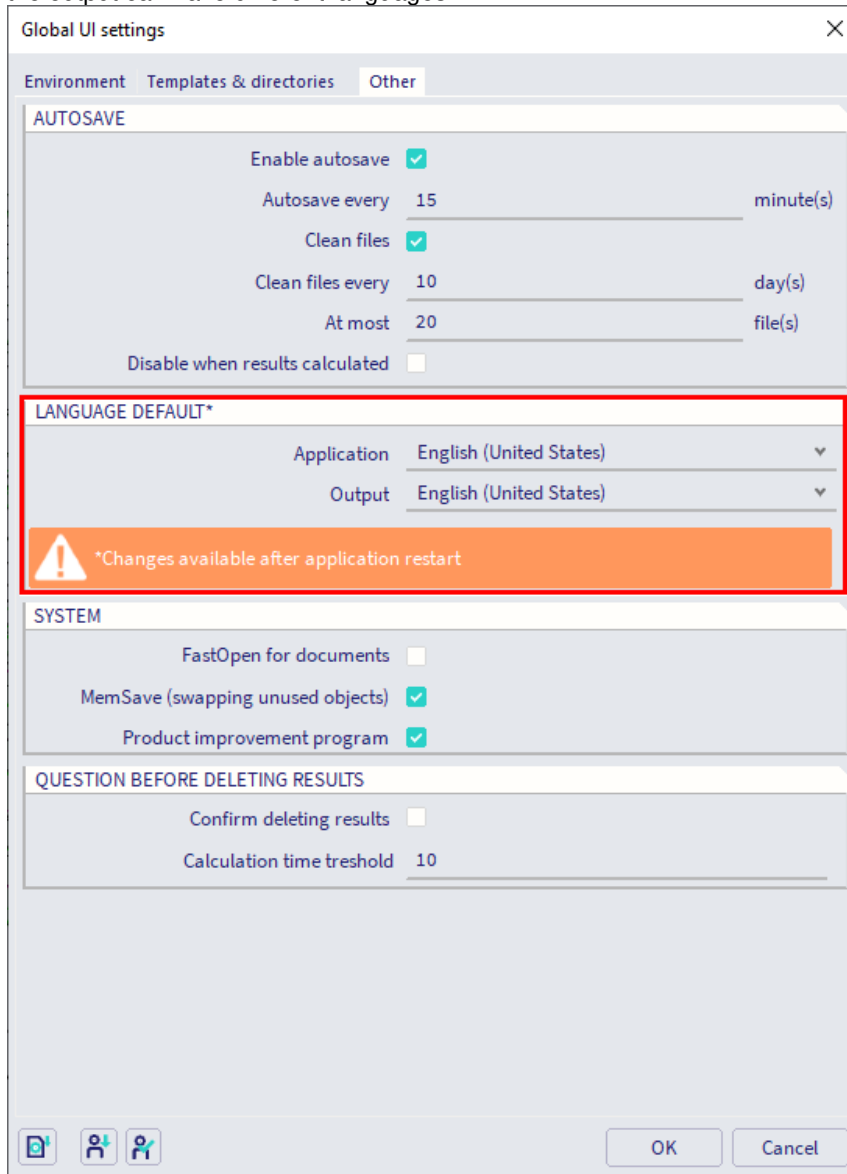

**NOTE:** only the installed languages are shown here. You should also have the language module(s) to be able to use them.

### 1.3. Project settings

The first action that you need to perform while starting a new project, is to define the project data. The project data window consists of the following tabs: 'Basic data', 'Functionality', 'Actions', 'Unit Set' and 'Protection'.

#### 1.3.1. Basic data

In the 'Basic data' tab you define some specific data for your project.

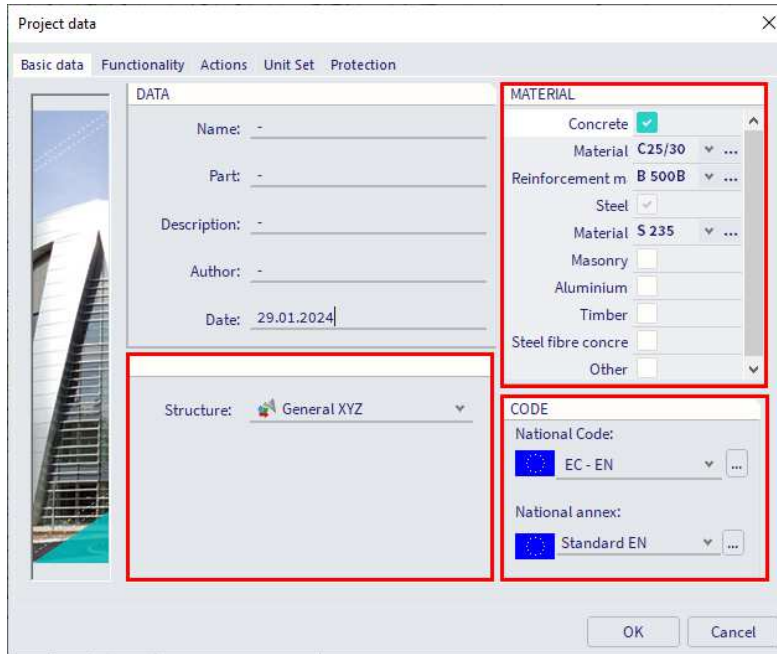

- **Material:** choose the materials that you want to use in your project and the default value of the quality.
- **Code:** select the code and national annex you want to apply.
- **Structure environment:**

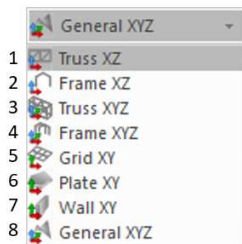

1		Only 1D-members, 2D environment, axial force only
2		Only 1D-members, 2D environment
3		Only 1D-members, 3D environment, axial force only
4		Only 1D-members, 3D environment
5		Horizontal grate
6		1D-members, 2D-members, 2D environment (Horizontal)
7		1D-members, 2D-members, 2D environment (Vertical)
8		Everything

### 1.3.2. Functionality

In this tab you need to check the functionalities that you want to use in SCIA Engineer. SCIA Engineer will automatically turn on some functionalities based on the basic data set.

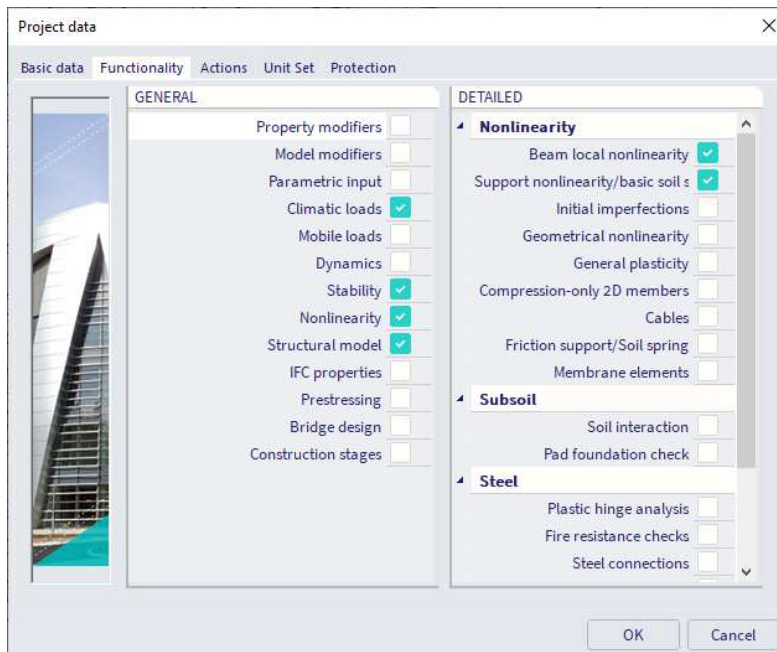

### 1.3.3. Actions

In this tab you can set the acceleration of gravity, the wind load, the snow load, the model factor for pond loads, the factor for concomitant components of a seismic combination and the automatic code combinations.

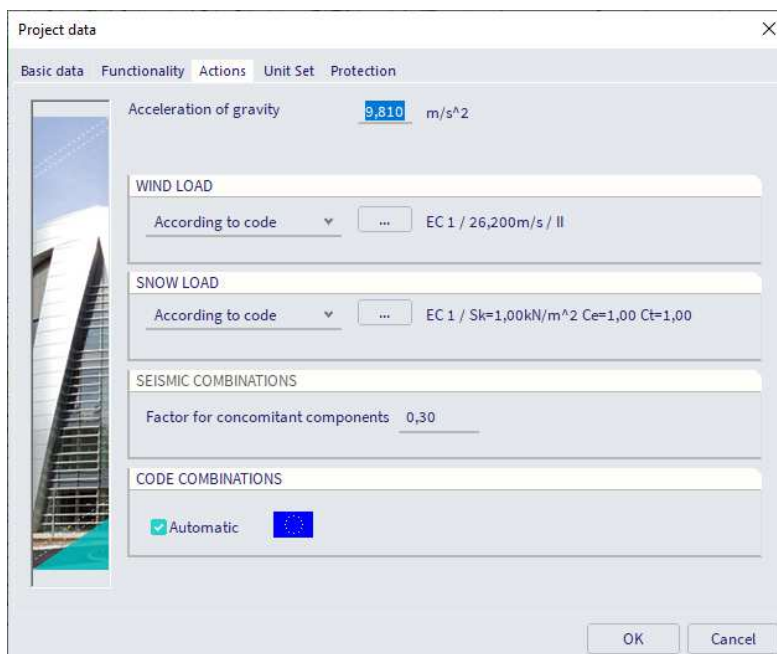



### 1.3.4. Unit Set

In this tab you can change from metric to imperial units, and via the Unit dialog you can configure the units used in the project.

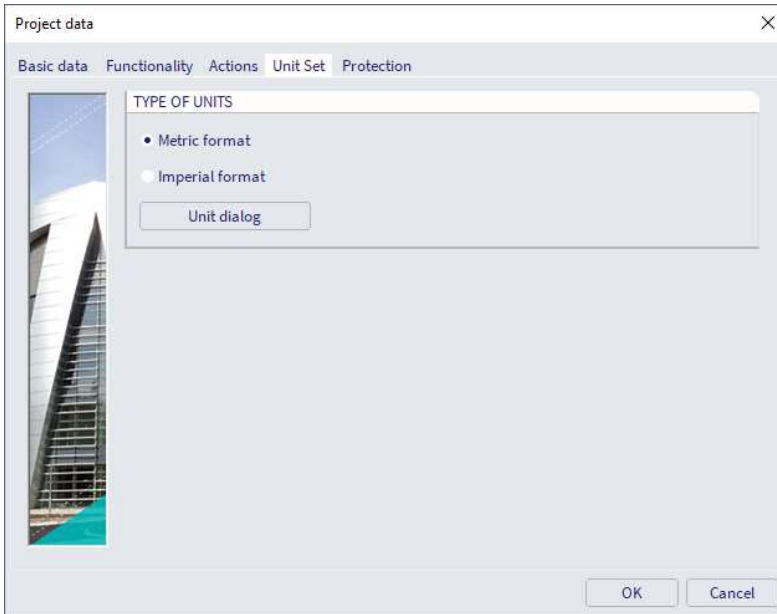

### 1.3.5. Protection

In this tab you can password protect your project.

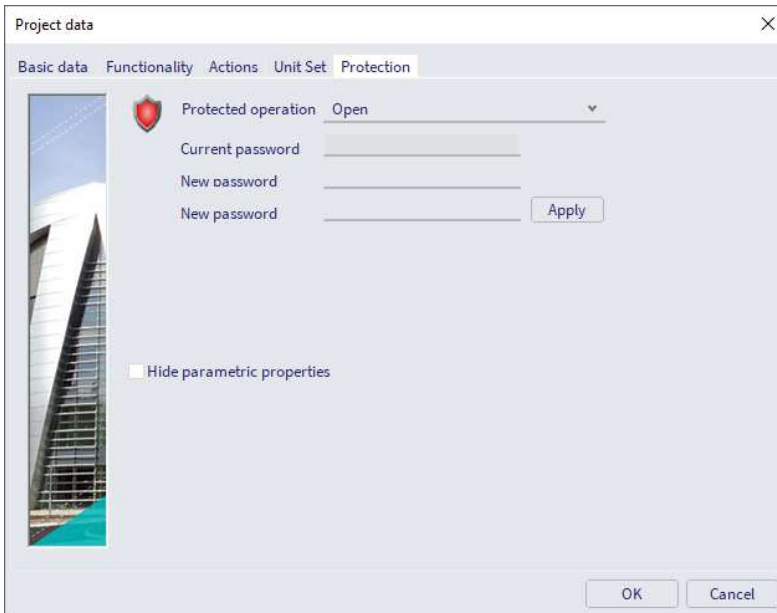

## Chapter 2: Modelling

### 2.1. Line grid

To insert a line grid and/or storeys, go to the input panel and choose the category 'Grids & Storeys'.

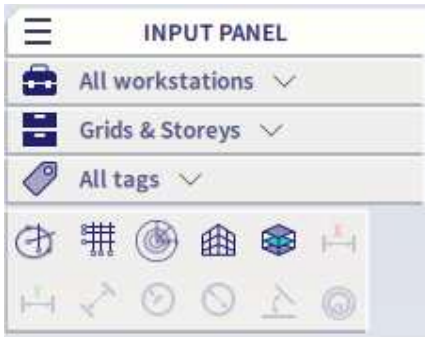

#### Free line grid

By using this option, you can draw free lines to create or to add to a line grid.

#### Rectangular grid / 3D line grid

In this menu you need to define the distance  $dx, y, z$  between two lines of the grid and the amount of lines (Rep).

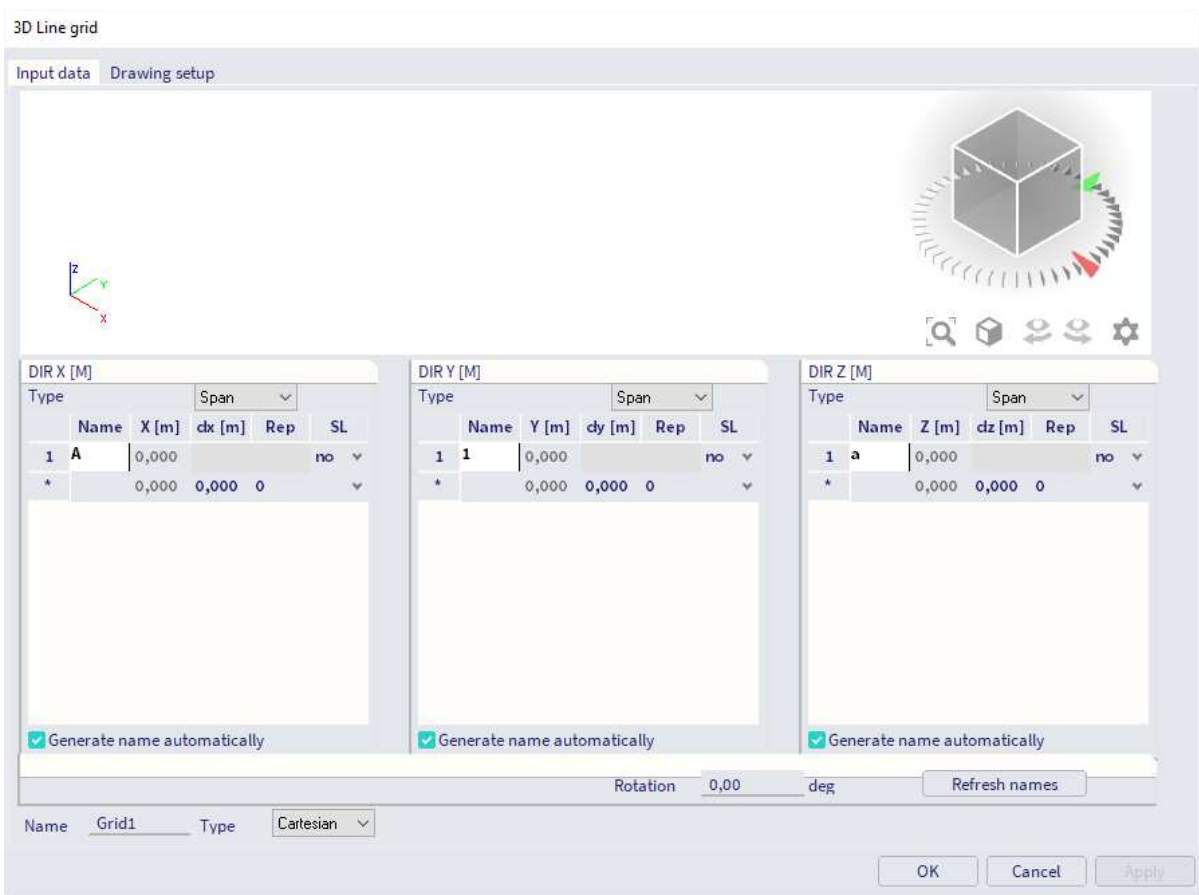

### Circular grid

To insert a circular grid, you need to define a distance dx and a rotation dy.

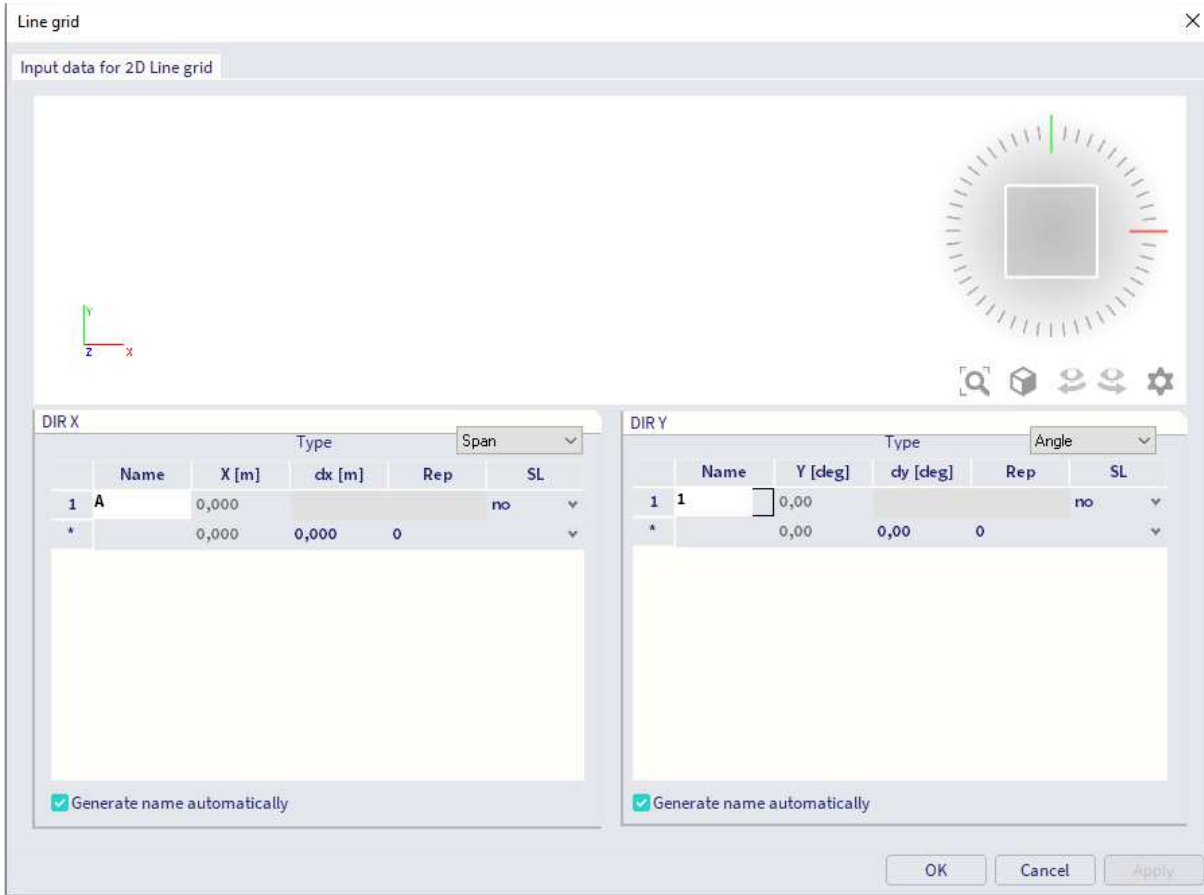

### Storeys

You can create different storeys and choose how elements are assigned to those storeys.

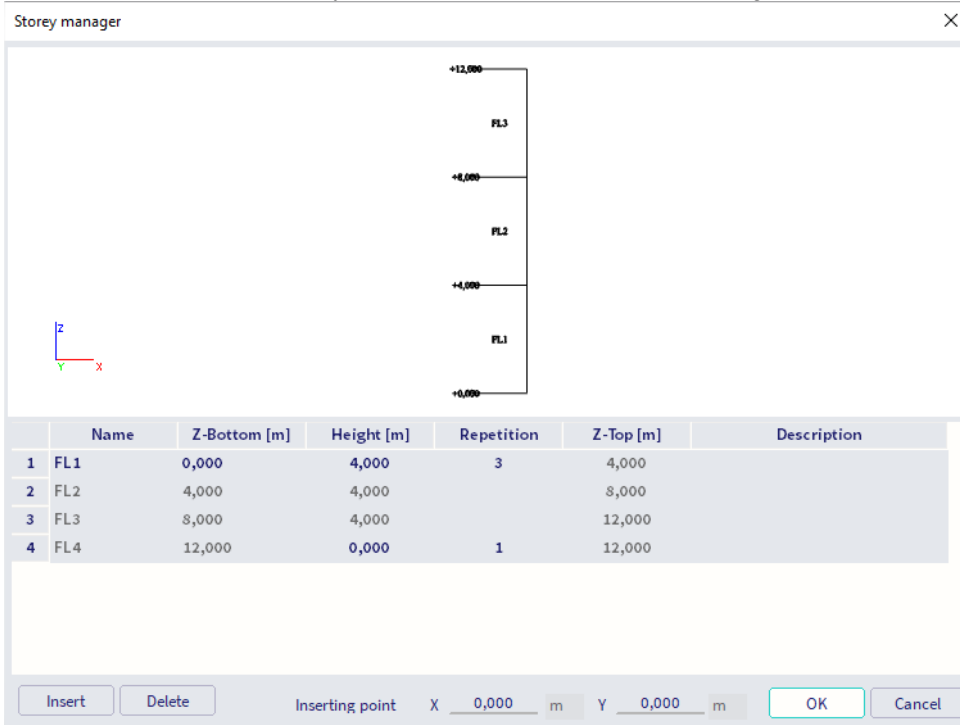

## 2.2. Views, visibility and layers

### 2.2.1. Views

There are 2 ways to change the view in the model.

#### 1. Using shortcuts

- CTRL + right click = rotate the model
- SHIFT + right click = move/pan the model
- SCROLL = zoom in/out

#### 2. Using the Navicube

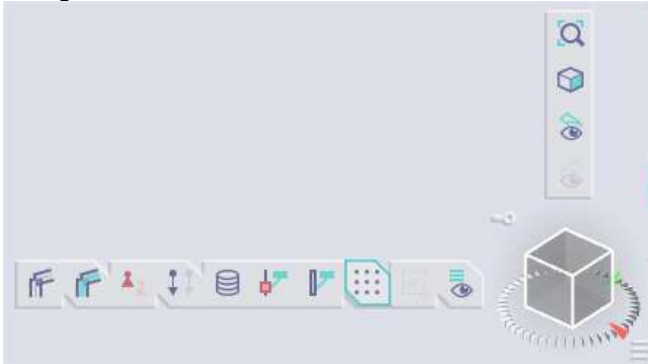

With the Navicube you can change the view in an easy way:

- Left click = rotate
- Right click = zoom
- Clicking on a plane will give you a view perpendicular to this plane
- Clicking on a corner will give an orthogonal view (from this point)

### 2.2.2. Visibility

In SCIA Engineer you can use 'Visibility to hide/show elements.

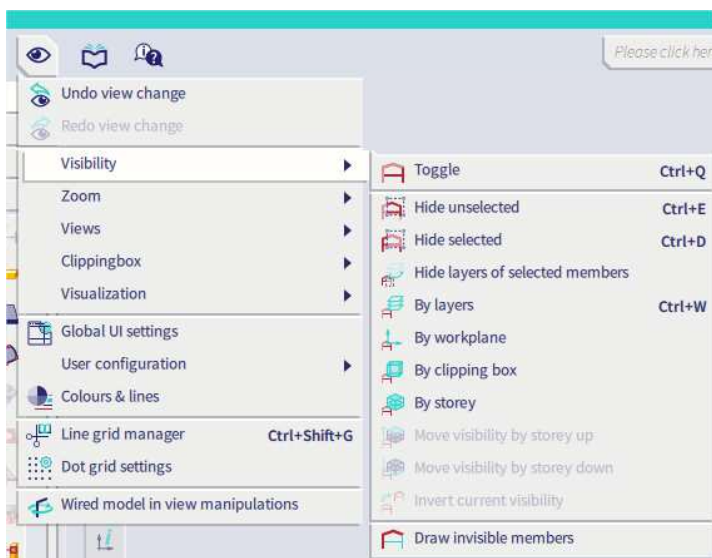

### 2.2.3. Layers

You can open the 'Layers' menu by going to **Libraries → Layers**

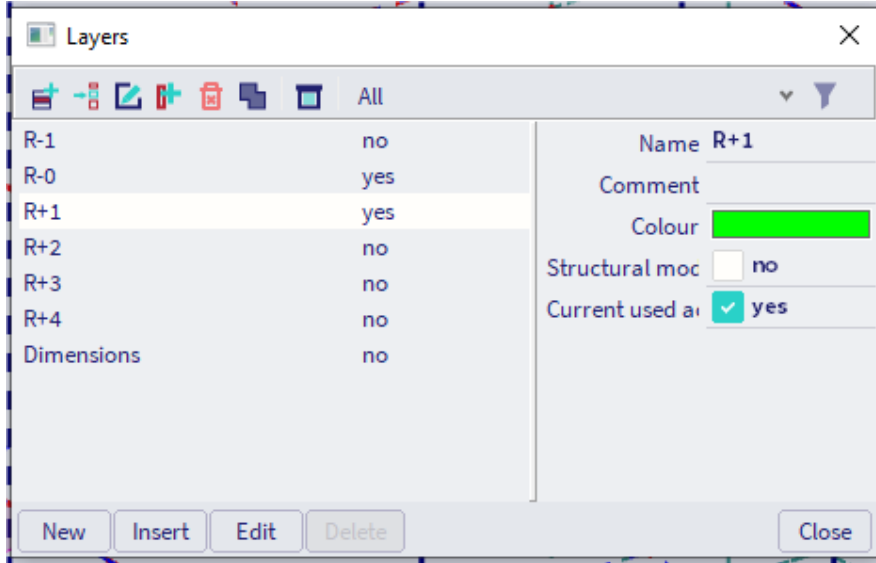

You can create layers in this window. There are 2 checkboxes which you can check or uncheck.

- **Structural model only:** if this is checked the elements in this layer will not be taken into account in the calculation.
- **Current used activity:** if this is unchecked the elements in this layer will not be visible.

You can assign elements to a layer by selecting them and changing the layer property.

### 2.3. Selection

When you hold the left mouse button, you can create a selection box to select multiple elements.

**Selection box with full line:** this is created by dragging the mouse to the right. With this selection box, you will only select the elements that are entirely in the box.

**Selection box with dashed line:** this is created by dragging the mouse to the left. With this selection box, you will select all the elements that are partially in the selection box. In other words, you will select all elements fully in the box + all elements that cross the box.

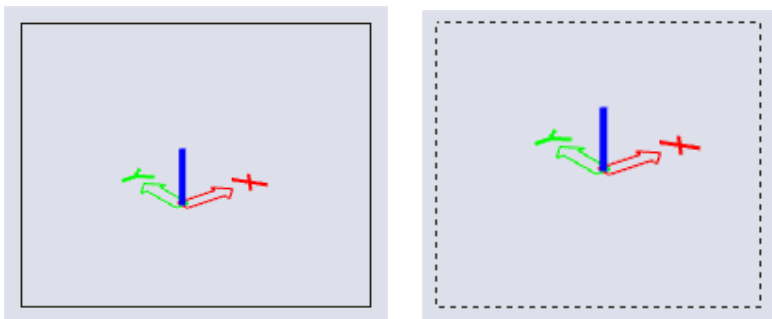

Next to selecting with the mouse, you can make some automatic selections and you can also save a current selection. This way you can load a previous made selection easily. You can find these options via **Tools → Selections**.

## 2.4. View settings for all entities

You can open the window 'View parameters setting' by right clicking → **View settings for all entities**. In this menu you can edit the view settings of your project.

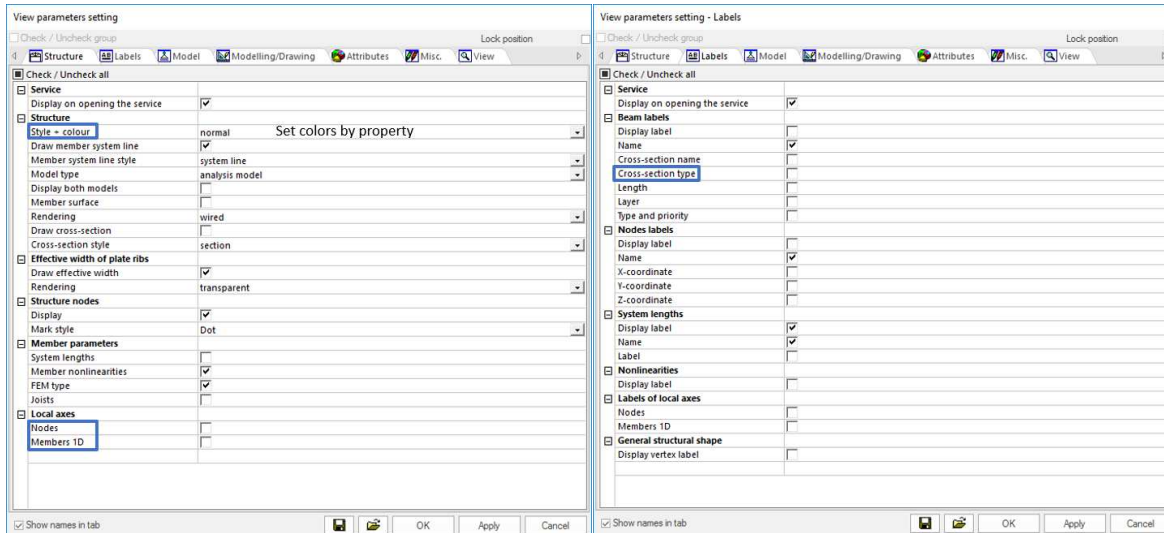

Some of the most used view parameters are highlighted:

- Colours by property: you can set the colour of elements in the model by element type, cross-section;
- Displaying local axes;
- Displaying the cross-sections type.

## 2.5. Material database

You can open the material database by going to **Libraries** → **Materials**. In this window you can view all the activated materials and their different qualities. When you click on a material, you can edit its parameters.

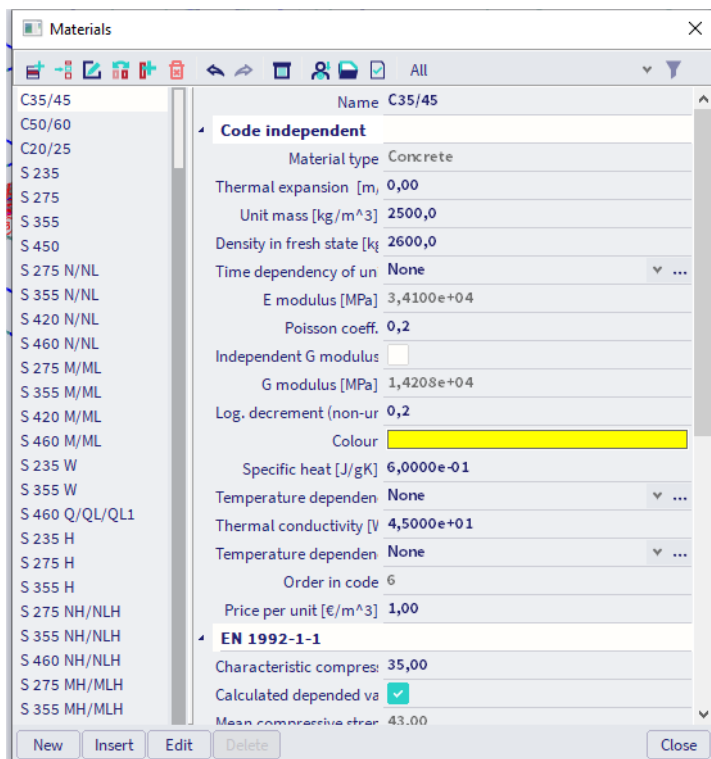

## 2.6. Cross-sections

You open the cross-section database by going to **Libraries → Cross sections**.

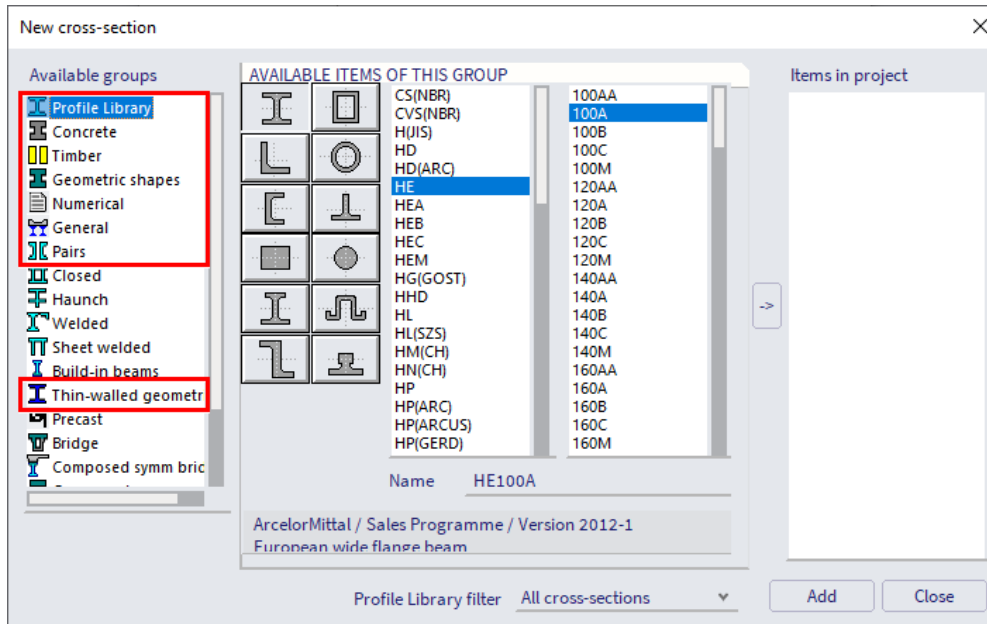

In the picture above the most used cross-sections are highlighted.

- **Profile Library:** you can find all standard (tabulated) profiles in the library.
- **Concrete:** you can use this option to create a concrete cross-section.
- **Geometric shapes:** with this option you can create a geometric cross-section. However, it is not advised to use this option. This will result in a thick-walled cross-section (buckling curves d) for steel. When you select this type of profile for concrete, you need to modify some settings. The best practice is that you use the option 'Concrete' for a concrete cross-section and the option 'Thin-walled' for a steel cross-section.
- **Numerical:** this option can you use to add a numerical cross-section. You can assign all the parameters to this cross-section without giving it a surface in the 3D-view. You can use this type for dummy elements.
- **General:** with this option you can draw a custom cross-section.
- **Pairs:** with this type you create a paired cross-section which results in a fully cooperative cross-section.
- **Thin-walled geometric shape:** with this option you create custom thin-walled (steel) cross-sections.



When you add a cross-section, the following window will open.

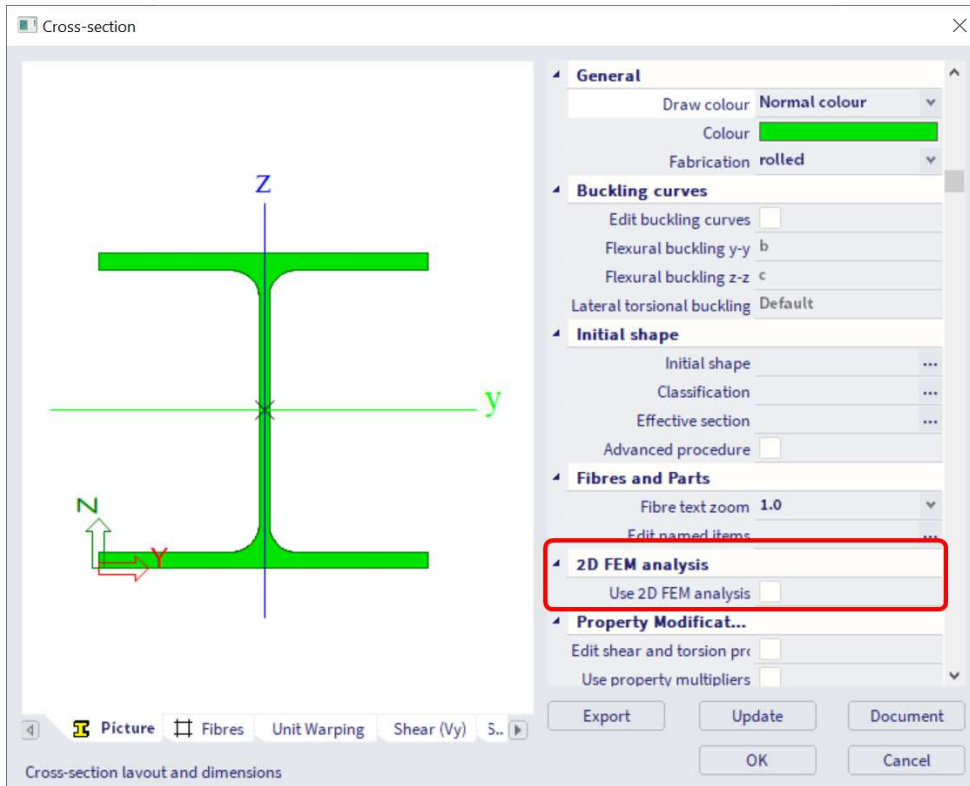

In this window you need to set the parameters. In order to view the calculated properties, you can press 'Update'. The properties of the cross-section are calculated when pressing 'OK'.

**Use 2D FEM analysis:** when this option is not checked, the properties are calculated with some simple formulas. If this option is checked, a mesh will be generated to calculate the properties. By checking this option  $A_y$ ,  $A_z$ ,  $I_t$  and  $I_w$  are calculated more accurately. This option is important to check – only for thick walled sections – if the cross-section is experiencing torsion.

**NOTE:** when you use a cross-section of the profile library, you don't need to set the settings above since the parameters and the properties are tabulated.

## 2.7. 1D elements

There are three ways to draw a 1D Member:



**Member:** with this option you draw a 1D Member by defining two points. This element automatically has the type 'general(0)' or 'beam(80)'. You can change the shape of the member by using the toolbar below (it appears under the SCIA Spotlight when you draw the member).



**Beam:** with this option you model a horizontal 1D Member by defining a point, a length, a direction and an insertion point. This element automatically has the type 'beam(80)'.

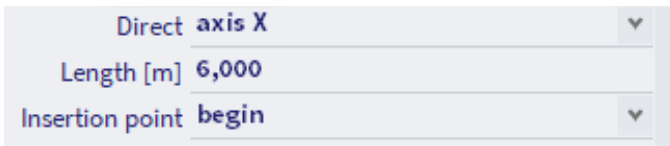

**Column:** with this option you can draw a vertical 1D Member by defining a point, a length and an insertion point. This element automatically has the type 'column(100)'.

**NOTE: the type is important for defining connections, to perform the ULS check of steel and to determine the calculation method in the 'Concrete' menu.**

Next to the settings above you also need to set some other parameters:

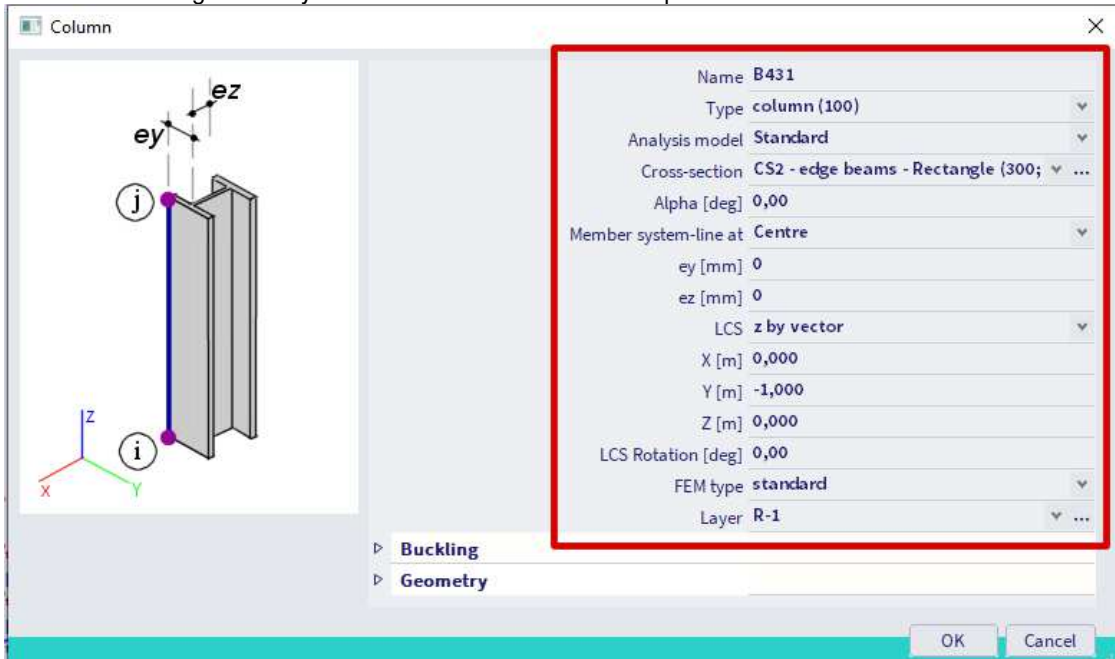

- **Cross-section:** set the cross-section.
- **Alpha:** rotate the member around its own axis. With this rotation you will not rotate the LCS (Local Coordinate System). This means that the LCS is different from the strong and weak axis of the profile.
- **Member system-line at:** change the system line of the member.
- **ey, ez:** add an eccentricity
- **LCS Rotation:** rotate the member around its own axis. With this rotation you will rotate the LCS together with the member.
- **FEM type:** here you can choose for a standard FEM analysis (bending + normal force) or axial force only. This option only needs to be changed for members that are only subjected to a normal force.
- **Layer:** set the layer.

Difference between rotations:

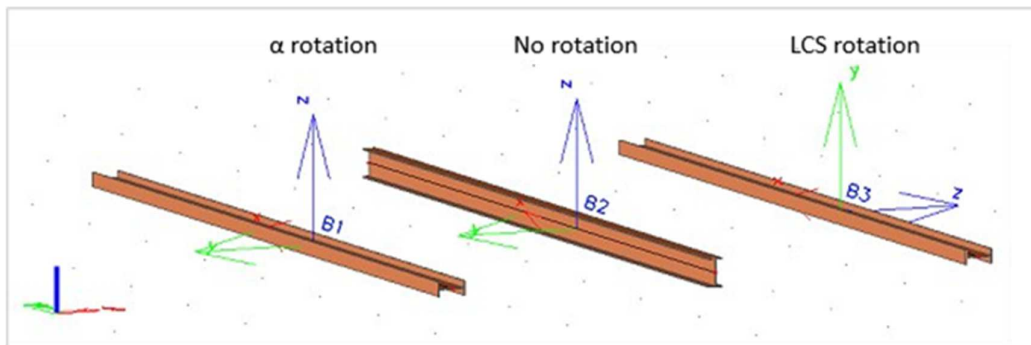

You can add 1D-member components to the elements. The type 'Haunch' is often used and is explained further in this manual.

## 2.8. 2D elements

There are three different types of 2D elements:

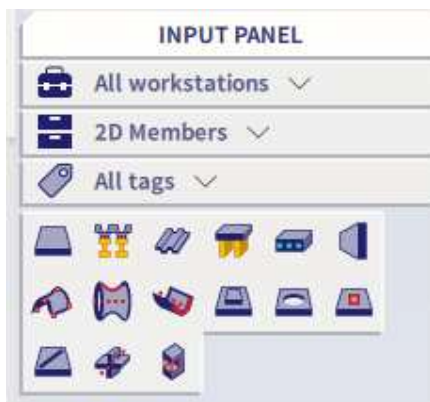

**Plates:** you define this 2D element by drawing the edge. You can change the shape of the edge by using the toolbar below (it appears under the SCIA Spotlight when you draw the plate). This element automatically has the type 'plate(90)'.



**Wall:** this 2D element you define by drawing the baseline (bottom or top) and by giving it a height. This element automatically has the type 'wall(80)'.

Height [m]	3,600
Insertion point	bottom

**Shells:** you define a shell element by drawing the edge, by a surface of revolution or by a swept surface.

Next to the settings above you have to set some parameters:



- **Type:** select the type.
- **Material:** select the material.
- **FEM model:** select the FEM model: 'isotropic' or 'orthotropic'. An orthotropic plate has different properties in perpendicular direction.
- **Thickness:** set the thickness of the plate. By default, you create a plate with a constant thickness. You can change it afterwards to a variable thickness in the property panel.
- **Member system-plane at:** set the member system plane: top, bottom or middle.
- **Eccentricity:** add an eccentricity to the plate.
- **LCS angle:** change the angle of the local axis of the plate.
- **Layer:** set the layer.

You can also add '2D Member components' to a plate:

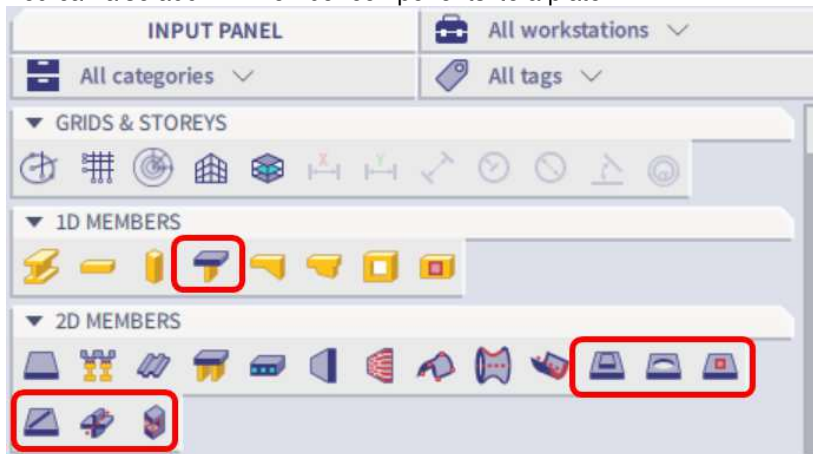

**Subregion:** create a subregion. This is an area of the 2D element that has another thickness and/or material quality than the rest of the 2D element.

**Opening:** create an opening in the 2D element.

**Internal node:** create a node on the 2D element.

**Internal edge:** create an edge on the 2D element. 1D elements parallel with the plate are only connected to the plate when there is an edge.

**Rib:** create a rib on the 2D element. A rib is automatically connected to the 2D element.

**Integration strip:** an integration strip makes it possible to view the result of a part of the 2D element as if it is a 1D member.

**Intersection:** create an intersection between two 2D elements. This will connect the 2 elements with each other.

**NOTE:** the function 'Internal node' is only applicable to insert a node within the polyline of the element. However, this function does not work when a node needs to be created on the edge of a 2D member. In order to insert a node on an edge of a 2D member, you can use the option Edit → Polyline edit → Add node.

## 2.9. Load panels

A load panel is a 2D element that transfers the applied load to its edges or nodes. The load panel adds no stiffness to the model.

You can find Load panels in the 'Structure' menu. There are four different types of load panels:



**Load to panel nodes:** the panel transfers the load to the nodes of the panel.

**Load to panel edges:** the panel transfers the load to the edges of the panel.

**Load to panel edges and beams:** the panel transfers the load to the edges of the panel and the beams in the plane of the panel.

**Panel with parallel beams:** same as the type above, however the beams will automatically be generated by using this function.

After you have chosen the type of panel, you need to set the properties. It is not necessary to set all the properties correctly before modelling the panel. You can modify the properties afterwards as well.



- **Load transfer direction:** you can choose the direction in which the loads are transferred. This can be direction X, Y or both. The X and Y direction follow the local axes of the panel.
- **Max. angle for transfer:** maximum allowed angle difference of an edge or beam, perpendicularly to the load transfer direction, in order to transfer the internal forces.
- **LCS angle:** rotate the LCS.
- **Max. eccentricity of members:** maximum allowed eccentricity of the members. If the eccentricity is higher than the set limit, the load will not be transferred.
- **Load transfer method:** there are four load transfer methods.

**1) Tributary area:** this method divides the surface in such a way that every separate part of the surface is 'carried' by the beam lying on its edge. This means that the load on this part of the surface is completely transferred to that beam. This method does not work for complex load panels. The advantage of this method is the quick calculation of the loads.

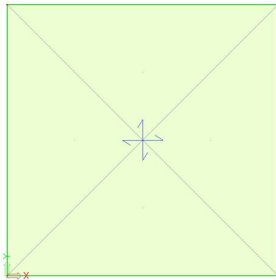

**2) Standard:** this method uses weight factors to divide the load between the beams. You can set the weight factors in the property panel.

Weight of loaded ed...	
LP1/B1	1
LP1/B2	1
LP1/B3	1
LP1/B4	1

**3) Accurate(FEM), fixed link with beam:** this method generates a mesh on the panel and uses a FEM calculation to determine the load distribution. For this option the beams have a fixed connection to the panel.

**4) Accurate(FEM), hinged link with beam:** this method generates a mesh on the panel and uses a FEM calculation to determine the load distribution. For this option the beams have a hinged connection to the panel.

**NOTE:** the FEM method allows to determine a load distribution on underlying elements based on the FEM response of an auxiliary plate with finite stiffness. The plate response is determined prior to the analysis of the 3D structure (upon pressing the 'Generate loads' action button).

The boundary conditions of this auxiliary plate affect the load transfer from the panel to adjacent elements and nodes. You can set the connection of the panels to the underlying beams at the panel edges as rigid or as hinges. You may choose between two options: 'fixed link with beams' or 'hinged link with beams', which results in different final load distribution. The resulting reactions of the background calculation of auxiliary plates are converted to the loads generated on the actual structure. In the case of 'rigid link with beams', moment reactions are ignored, as these do not originate in the structural response.

- **Selection of entities:** the entities/beams on which the load is transferred, are automatically selected. You can overwrite the automatic selection by changing this option to 'user selection' or 'type'.



When you select **'user selection'** you need to press the action button **'Update edge/beam selection'** and select/deselect the members.

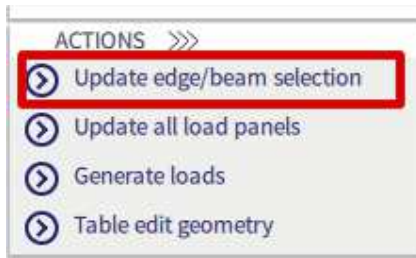

When you select **'type'** you need to check/uncheck the types taken into account.

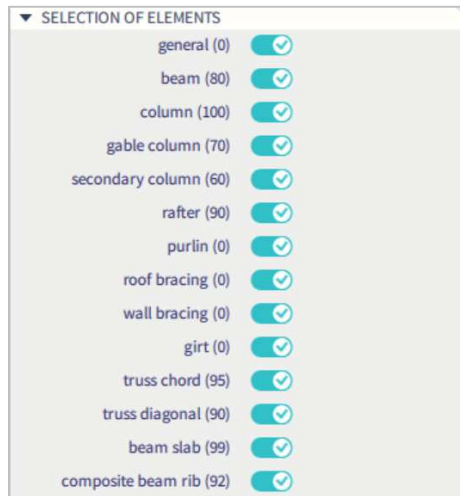

## 2.10. Supports

You can input supports via the input panel.



**In node:** you can only assign this type of support to a node.

**Support on 1D:** you can put this point support along the length of a member. You need to define the relative or absolute position of this support along the length of the member.





**Line support on 1D:** you can put this line support along the length of a member. You need to set the relative or absolute position and the length of this support along the length of the member.

**Line support on 2D edge:** this is a line support which you can define on a 2D member edge. You need to set the relative or absolute position and the length of this support along the length of the edge.

**Surface support on 2D:** this is a surface support that you can define on a 2D element or a subregion. You need to choose a subsoil in which the stiffness parameters define the boundary conditions. More information can be found in the chapter related to subsoils.

Name	SS8
Type	Individual
Subsoil	Sub1

Next to the support position you need to define the constraints (boundary conditions) as well

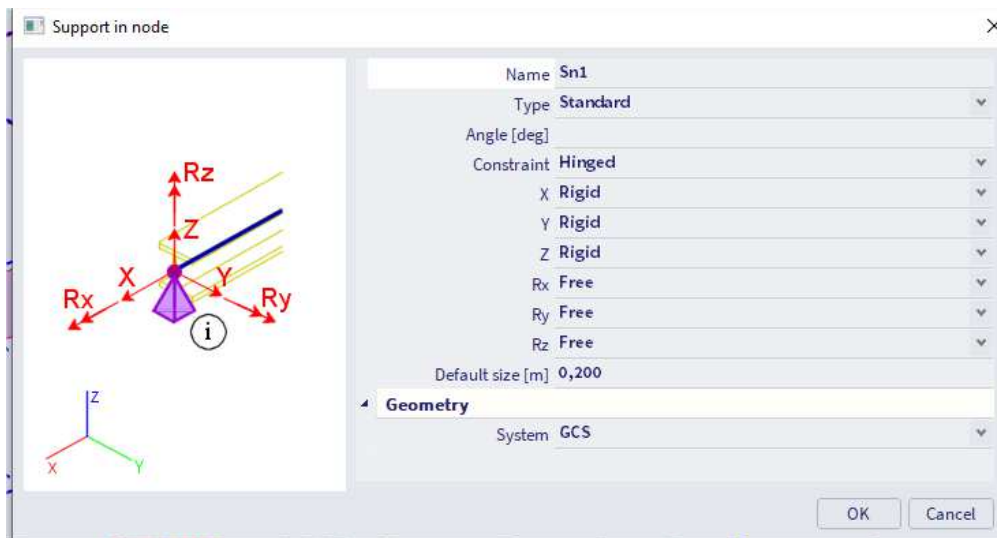

- **Angle:** as default the support follows the local axes of the node. You can give it a rotation relative to the LCS by using  $R_x(\text{angle}), R_y(\text{angle}), R_z(\text{angle})$ . For example:  $R_x90, R_y90, R_z90$ .
- **Constraint:** you can choose a default constraint: 'fixed', 'hinged' or 'sliding'.
- **X, Y, Z, Rx, Ry, Rz:** you can change these values to set a custom constraint. Also flexible or non-linear constraints are possible.
- **Default size:** this option is only used for the moment reduction above a support of a continuous beam and punching checks (for concrete structures).

## 2.11. Catalog blocks

You can find the catalog blocks in the input panel in the “Import & Blocks” category.

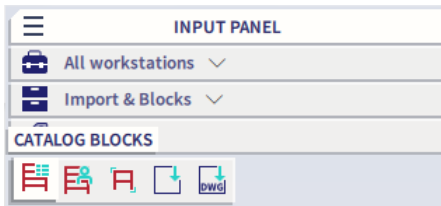

With catalog blocks you can import frames and trusses in an easy and fast way.

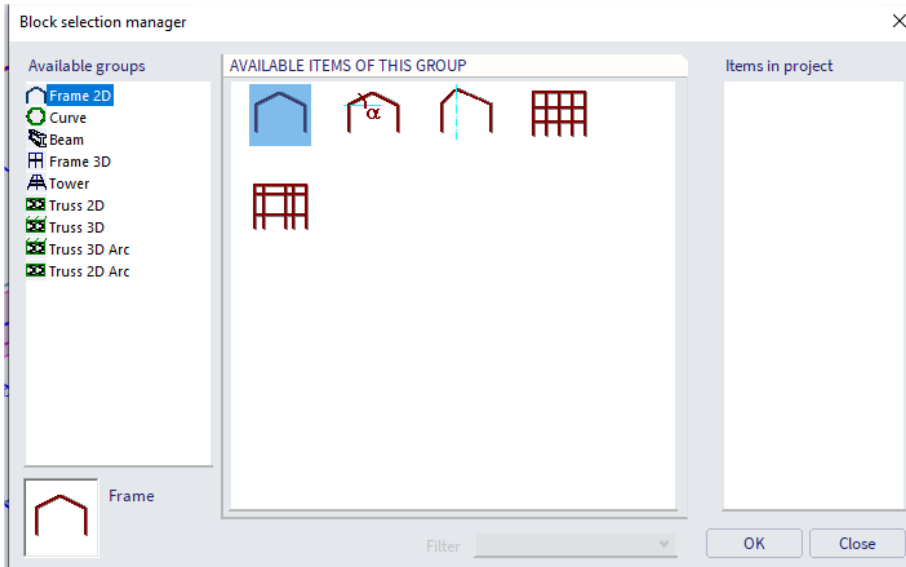

Select the predefined block you want to add to your model and set the parameters.

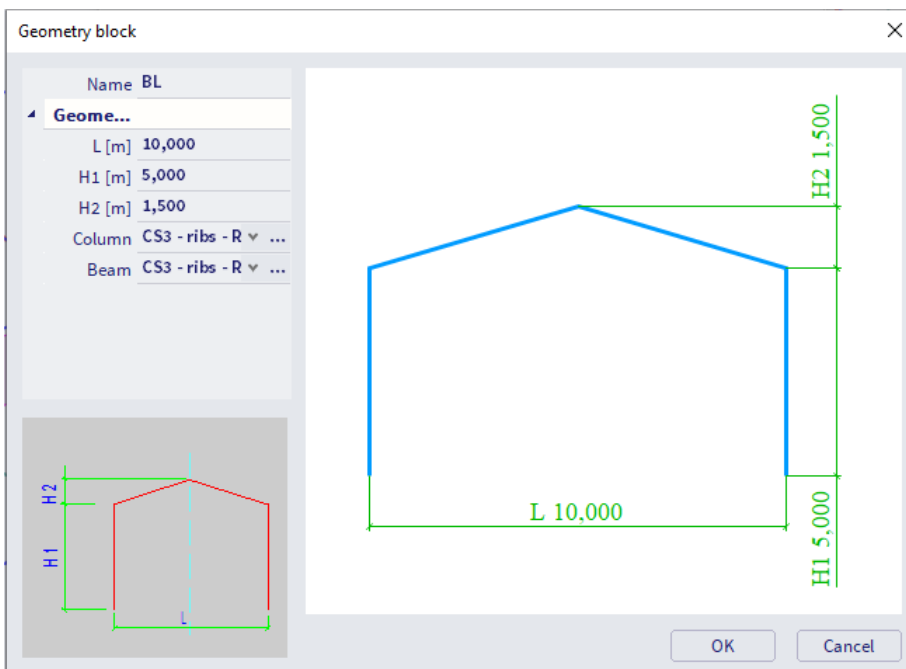

After pressing ‘OK’ you can add the catalogue block to your model. The catalogue blocks consist of 1D members that are fully connected to each other.

## 2.12. Haunch

In the Input Panel under category '1D Members', you can find the function 'Haunch on 1D'.

Before you can define a haunch, you need to add a cross-section of the type 'Haunch'. This is the cross-section at the beginning of the haunch, more specifically the largest cross-section. You can add the cross-section in the 'Cross-section' menu OR you can click on the 'Haunch' function to automatically open this window.

First select the type of haunch and press 'Add':

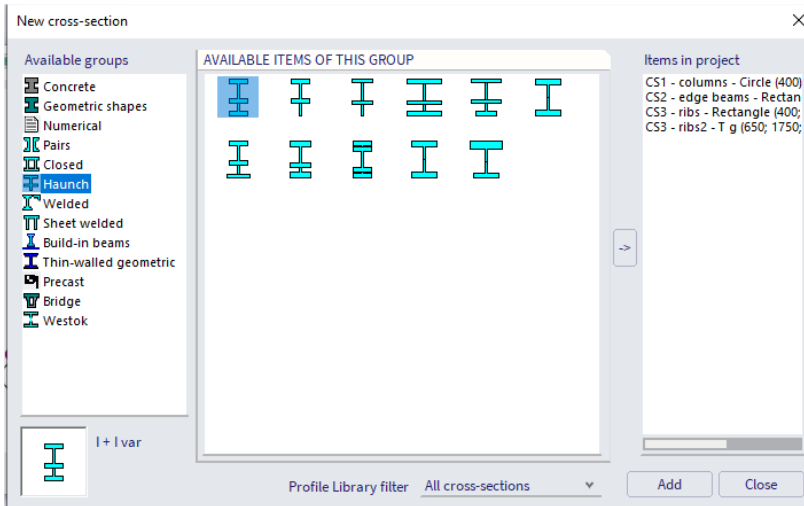

Then you need to fill in the parameters of the cross-section.

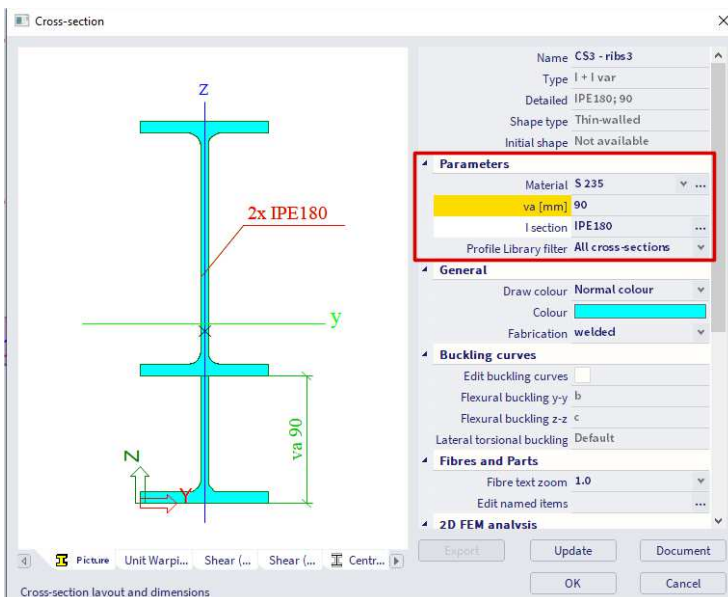

Confirm with OK → Close → OK

In the last step you define the position (in the beginning or at the end of the beam) and the length (relative or absolute) of the haunch.

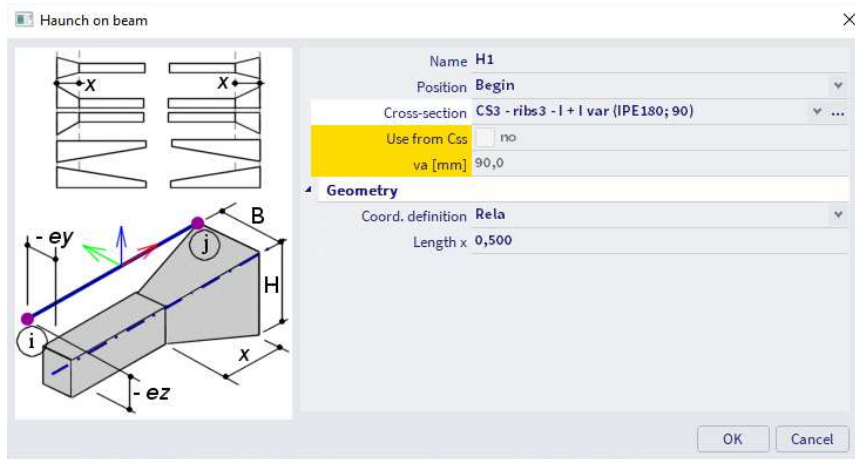

A haunch is model data you put on a member. This means if you select the surface of the member, you are not selecting the member itself but only the additional data 'Haunch'. In order to select the member, you need to select the centerline.

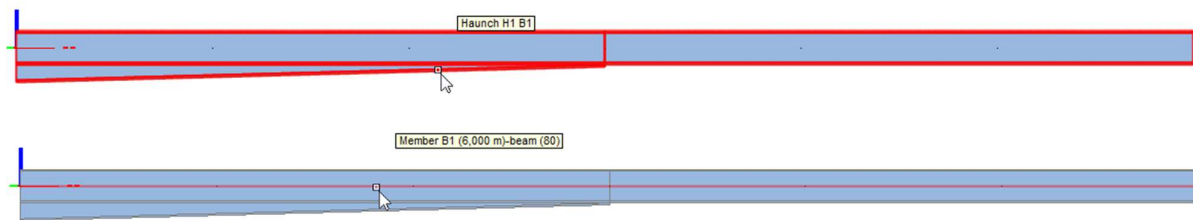

A haunch is calculated by the solver in 5 segments with each segment having its own, constant cross-section. You can increase this number of segments in **Tools → Calculation & Mesh → Mesh settings**

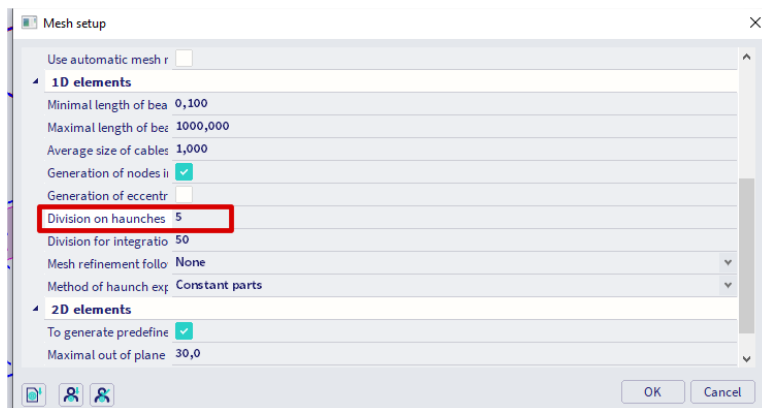

**NOTE:** if you want to have a different haunch at the beginning and at end of a beam you need to cut the beam in half.

## 2.13. Hinges

By default, every node in your project is considered fixed, unless your project is modelled in a truss environment. In order to make a member hinged, you need to add a hinge to the member. A hinge is considered as additional data you add on a member.

You can find the hinges in the Input Panel under category 'Boundary conditions':



To add a hinge you need to define the degrees of freedom and the position (begin, end or both sides of the beam).



The hinge is visualised in SCIA as in following figure:

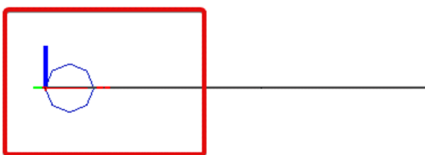

## 2.14. Beam non-linearity

It is possible to add non-linear behaviour to a beam. To enable this option, you need to tick following functionalities in the 'Project':

- nonlinearity;
- beam local nonlinearity.

You can find the option 'Nonlinearity 1D' in the 'Boundary conditions' category in the input panel. You need to choose the nonlinearity type in the following window.

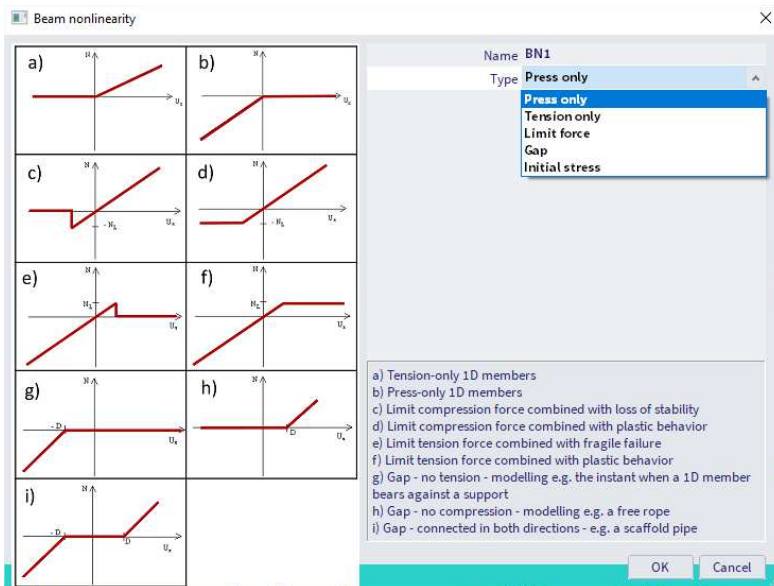

You need to perform a nonlinear calculation to consider the nonlinear behaviour. Therefore, you should create nonlinear combination(s). Chapter 3 explains the creation of loads and combinations.

**NOTE: the most used nonlinearity type is 'Tension only'. It is used to model wind bracings. Best practice is to combine the 'Tension only' type with the 1D member property 'axial force only'. See the chapter about 1D members to check how this is enabled.**

## 2.15. Subsoil

If there is a 2D element in your model, you can add a 'Surface support on 2D' from the Input panel under categorie 'Boundary conditions'.



You can define a subsoil yourself, or you can import one of the predefined subsoils (according to NEN 6740) from the library.

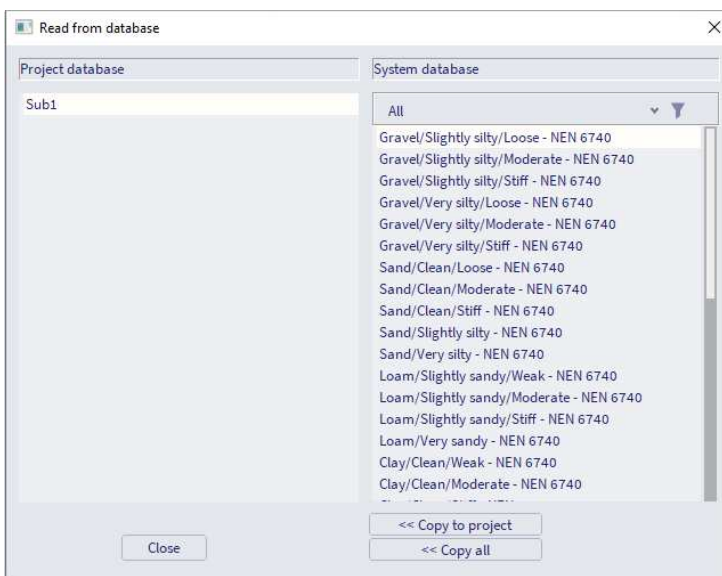
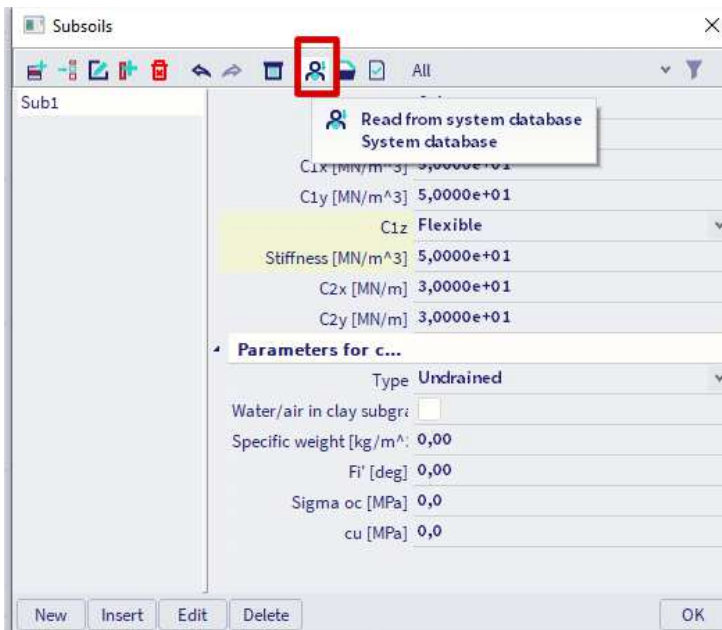

Now you should set the following parameters before adding the subsoil to your model:

- **C1z**: stiffness of the ground in Z direction.
- **C1x, C1y**: stiffness of the ground in horizontal direction. If these values are not known 10% of the stiffness in Z direction can be taken as an approach.
- **C2x, C2y**: these values couple the deformation in Z direction between different sections of the ground. The image below shows the theory of Winkler (picture a) where these parameters are 0. Picture b illustrates the theory of Pasternak where the C2 parameters have a certain value. Usually these values are not determined, and the values are set to 0.

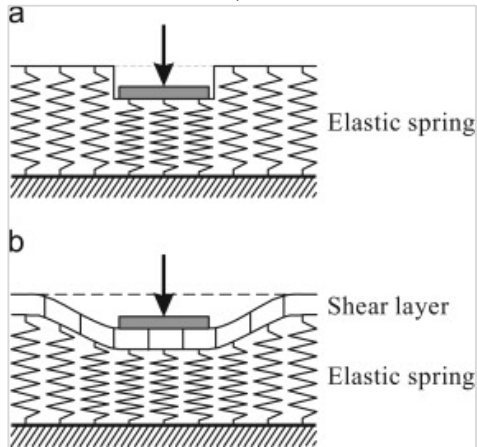

## 2.16. Modify shape

There are three ways you can modify the shape of elements.

### 1) With property panel

You can change the shape of an element by editing the coordinates of the nodes of the element. If a node is in the current selection, you can change the coordinates in the property panel.

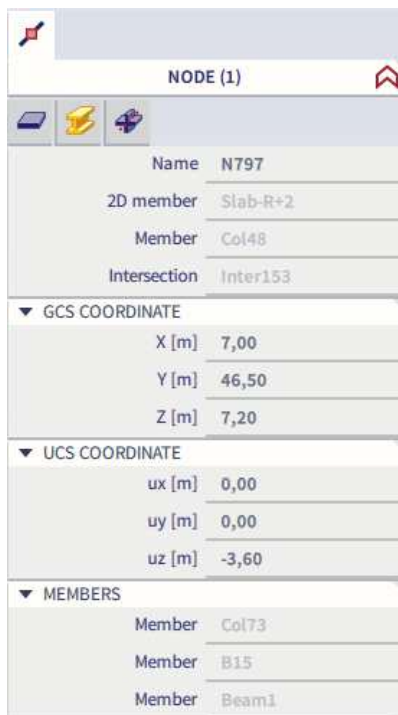



## 2) With the action 'Table edit geometry'

You can edit the shape of an element by selecting it and clicking on the action button 'Table edit geometry' on the bottom of the properties panel.



In this table you can edit the coordinates of the nodes of the element.

Editing geometry									
	Node name	X [m]	Y [m]	Z [m]	ux [m]	uy [m]	uz [m]	Linked	Shape
1	N547	14,000	39,500	-3,600	7,000	-7,000	-14,400	<input type="checkbox"/> Rela	Line
2	N548	21,000	39,500	-3,600	14,000	-7,000	-14,400	<input type="checkbox"/> Rela	Line
3	N516	21,000	39,500	0,000	14,000	-7,000	-10,800	<input type="checkbox"/> Rela	Line
4	N515	14,000	39,500	0,000	7,000	-7,000	-10,800	<input type="checkbox"/> Rela	Line
*		0,000	0,000	0,000	0,000	0,000	0,000	<input checked="" type="checkbox"/> Rela	

OK Cancel Apply

## 3) By clicking and dragging

When you have selected a node, an element or several nodes, you can move these by holding the left mouse button on top of it, clicking and dragging the mouse towards the new location.

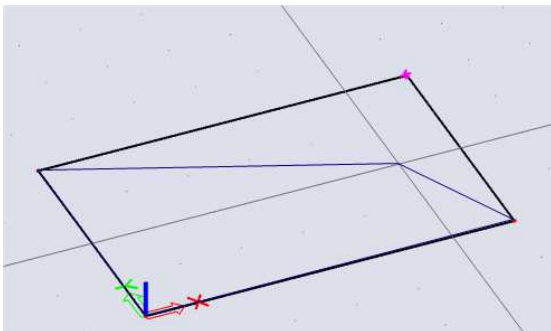

## 2.17. Connect members

It is important to know that not all members are connected automatically. The scheme below provides a graphical representation of all the members which you need to connect by yourself. The connect algorithm can be found in **Edit → Modify → Connect members/nodes**.

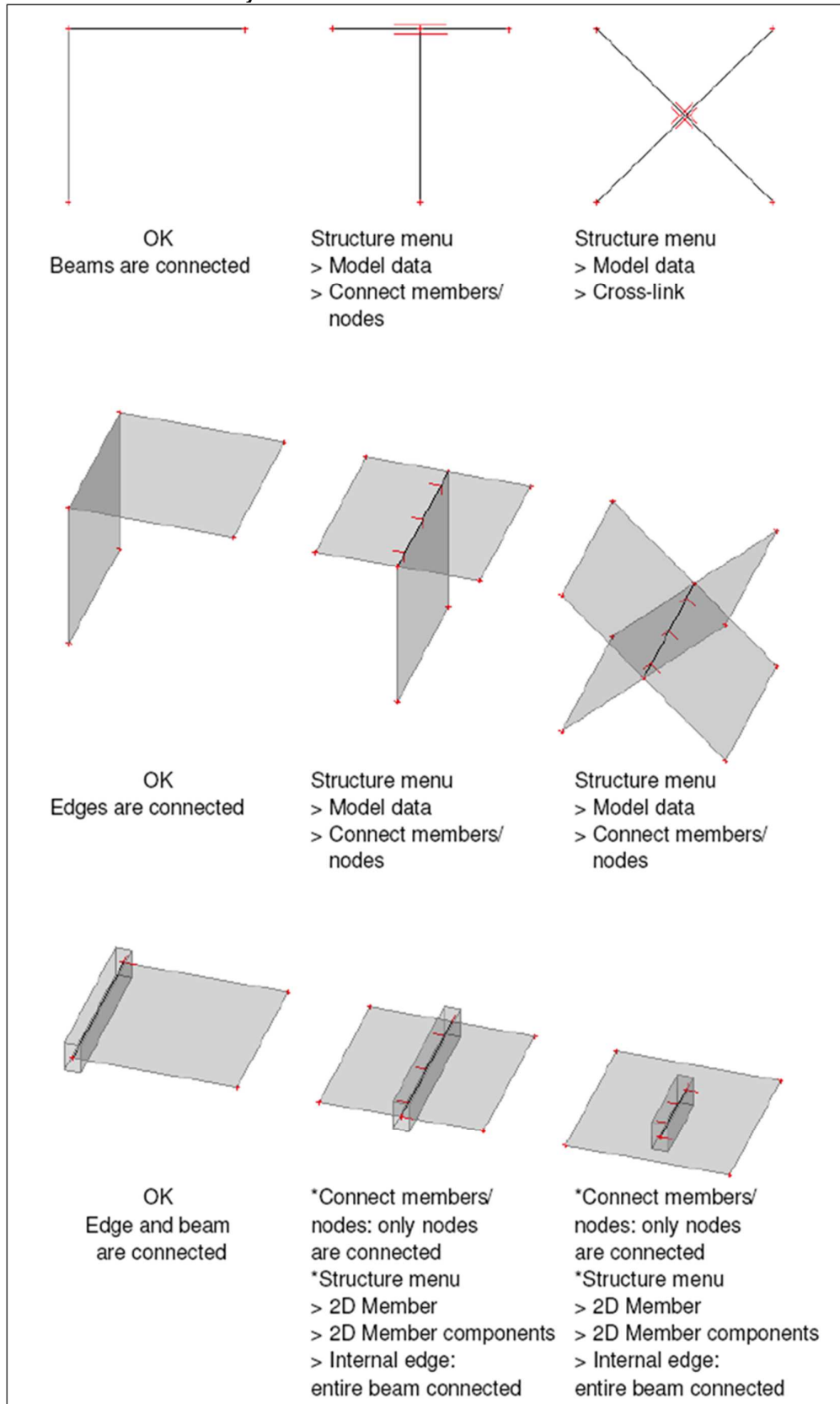

## 2.18. Check structure data

As soon as you have completed your model and before you run the calculation, the 'Check structure' function should be executed. This function checks if there are errors in the project, more specifically duplicate elements, corrupt data, ...



If there are no issues in the model the following window will appear.

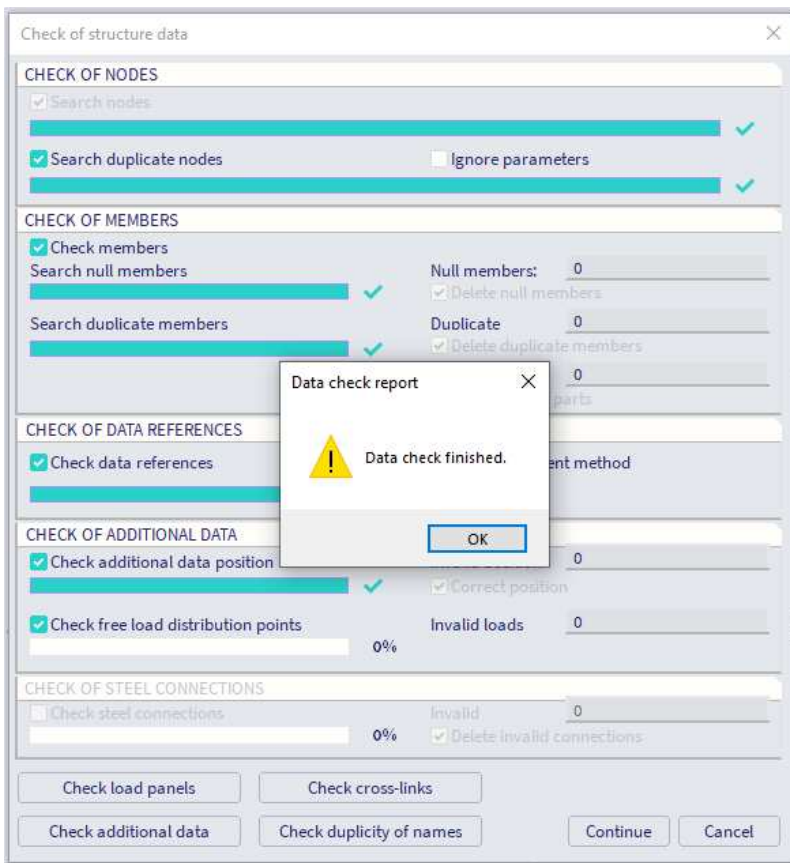

## 2.19. Modification commands

In this chapter you can find some explanation about modification commands. The steps you need to follow to successfully complete a modification command are shown in the command window. You can find the modification commands under **Edit → Modify**.

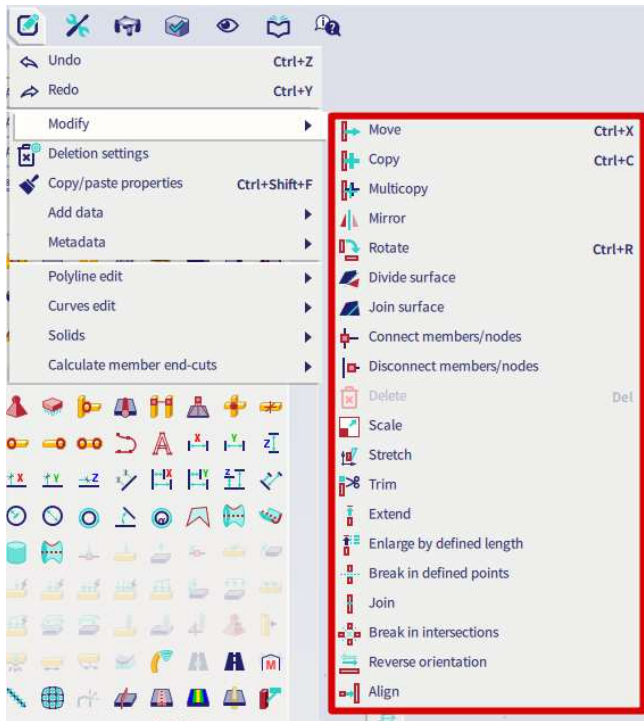

### 2.19.1. Copy

Press the 'Copy' command or use the shortcut CTRL+C.

Below you can see the actions you should take to perform the copy command. You can find these steps in the SCIA spotlight.

Copy - Select entities to be copied (finish selection with ESC) >

Copy - Start point >

Copy - End point >

### 2.19.2. Multicopy

In order to perform a more advanced copy, you can select the 'Multicopy' command.

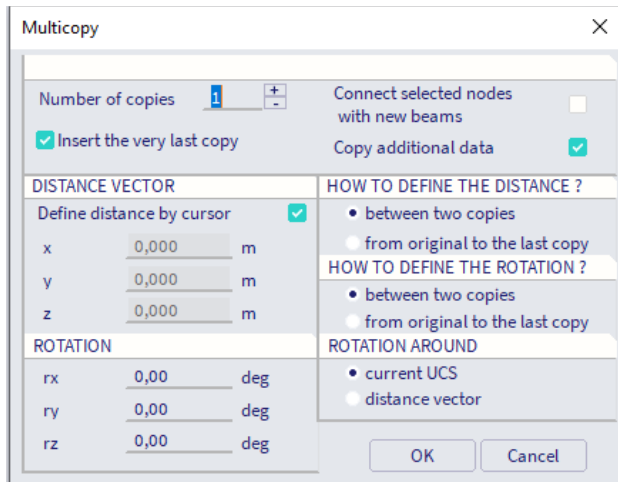

- **Number of copies:** set the number of copies.
- **Insert the very last copy:** this option defines the number you need to fill into the 'Number of copies' field. If this option is checked and the 'Number of copies' is 7, 7 copies will be made. If the option is unchecked and the 'Number of copies' is 7, 6 copies will be made. The existing selection counts as the first copy.
- **Connect selected nodes with new beams:** if this is checked, all the nodes in the current selection will be connected with beams to the same nodes of the next copy.
- **Copy additional data:** when this is checked, all additional data of the selection (supports, haunches, ...) will be copied as well.
- **Distance vector:** setting values for this vector will define the distance/rotation between copies.

### 2.19.3. Mirror

Use the 'Mirror' command.

Below you can see the actions you should take to perform the 'Mirror' command. You can find these steps in the SCIA Spotlight.

Mirror - Select entities to be mirrored (finish selection with ESC) >

Mirror - Mirroring plane - Start point >

Mirror - Mirroring plane - End point >

### 2.19.4. Break in defined points

Use the 'Break in defined points' command to divide a member into multiple segments.

Below you can see the actions you should take to perform the 'Break in defined points' command. You can find these steps in the SCIA Spotlight.

Divide - Select curves to be divided (finish selection with ESC) >

Divide - Insert division points >

## 2.20. Input table

In SCIA Engineer elements are often drawn, but you add them as well via 'Input table'. The 'Input table' window has a tab per type of element (nodes, 1D elements, 2D elements, ...). The tabs are highlighted in the picture below. You need to fill in the green cells to add an element. If a tab is missing, you can add it by right-clicking on another tab and choosing the missing tab. The same works for the column names.



You can copy the content of the table to Excel and vice versa. In order to do this, you can use the short cut CTRL+C.

You can copy rows in the input table to perform an action similar to the 'Copy' function. To do this you need to select (the rows of) the elements, fill in the distance between the copies (separated by a space and preceded by '@') and then press the 'copy row' button.



The input table offers multiple features such as a Filter, Select by property in cell, ...

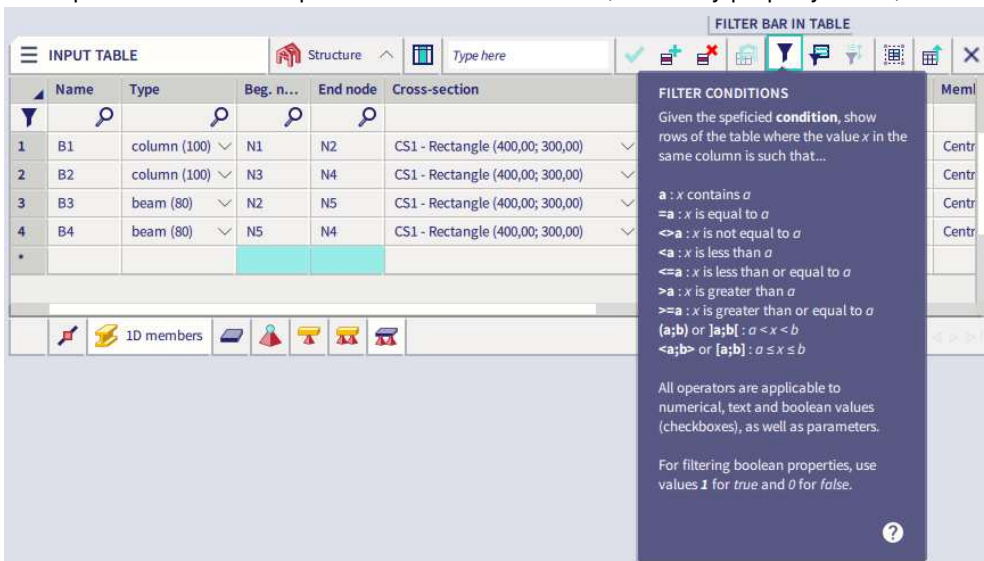

## Chapter 3: Loads

### 3.1. Load cases

For every load you can create a load case. In the settings of the load case, you determine if it is a permanent or variable load and to what load group the load case is assigned. These two settings are important to generate the correct combinations.

You can open the Load cases window via the **Main Menu → Libraries → Load cases, combinations.**

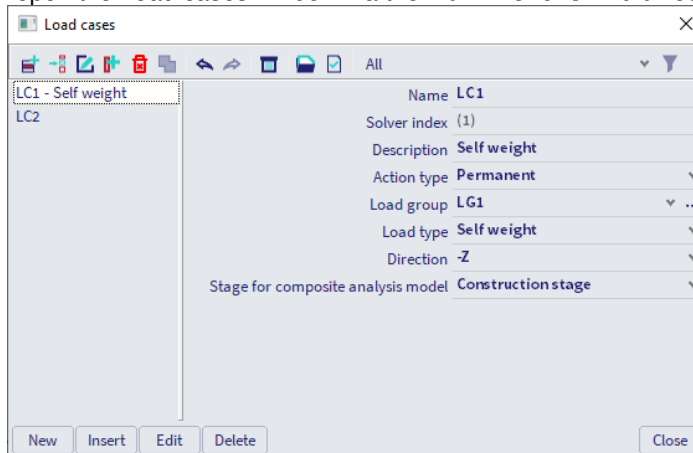

In the Status Bar, you can select the active load case to draw/define the loads:



### 3.2. Load groups

With load groups you define the type of load and the relation between the loads in this group. Depending on the type of load case (permanent or variable) you can define the matching load group.

#### 3.2.1. Permanent load group

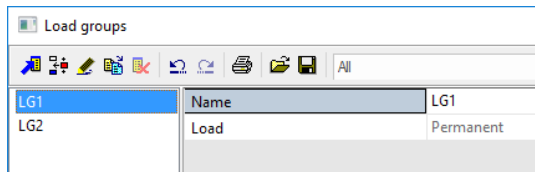

There is only one permanent load group per project, because all the permanent loads should be summed up and they do not have different categories.

$$\left\{ \sum_{j \geq 1} \gamma_{G,j} G_{k,j} + \gamma_P P + \gamma_{Q,1} \psi_{0,1} Q_{k,1} + \sum_{i > 1} \gamma_{Q,i} \psi_{0,i} Q_{k,i} \right. \quad (6.10a)$$

$$\left\{ \sum_{j \geq 1} \xi_j \gamma_{G,j} G_{k,j} + \gamma_P P + \gamma_{Q,1} Q_{k,1} + \sum_{i > 1} \gamma_{Q,i} \psi_{0,i} Q_{k,i} \right. \quad (6.10b)$$



### 3.2.2. Variable load group

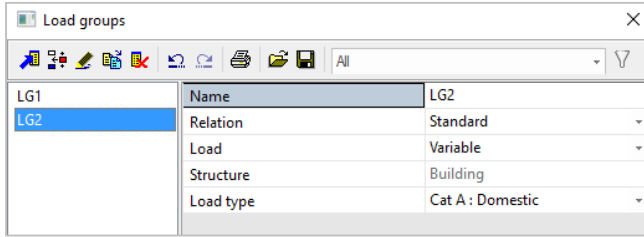

Compared to the permanent load group you can define multiple variable load groups. For every type of load (wind, snow, ...) you can create a different load group. This is because in 6.10a(b) the different type of loads should vary between the main variable group and the sub variable group. The different types of loads are defined by the option 'Load type'. With the load type you can set the category of the load. This way the program knows what psi factors to use (according to Eurocode 0).

$$\left\{ \sum_{j \geq 1} \gamma_{G,j} G_{k,j} + \gamma_P P + \gamma_{Q,1} \psi_{0,1} Q_{k,1} + \sum_{i > 1} \gamma_{Q,i} \psi_{0,i} Q_{k,i} \right\} \quad (6.10a)$$

$$\left\{ \sum_{j \geq 1} \xi_j \gamma_{G,j} G_{k,j} + \gamma_P P + \gamma_{Q,1} Q_{k,1} + \sum_{i > 1} \gamma_{Q,i} \psi_{0,i} Q_{k,i} \right\} \quad (6.10b)$$

You should also define the relation between the loads in the same load group.

- **standard:** all combinations are possible.
- **exclusive:** only one load of every load group can be present in a combination.
- **together:** the loads can only be present together in a combination.

**EXAMPLE:** assume the load cases LC A and LC B which are both assigned to the same load group.

- standard: LC A and/or LC B
- Exclusive: LC A or LC B
- together: LC A and LC B

### 3.3. Combinations

You can choose between three types of combinations. The differences will be explained below. To add a combination, go to the **Main Menu → Libraries → Load cases, combinations** and select Combinations.

By default, there are 3 Eurocode combinations automatically generated:

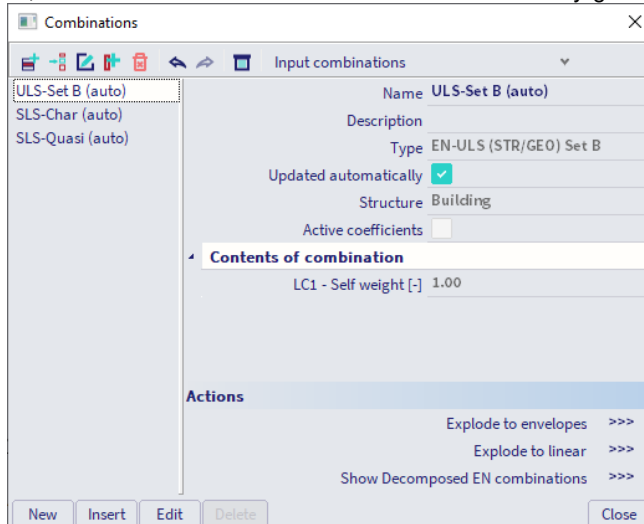



To create a new combination, use the [New]-button:

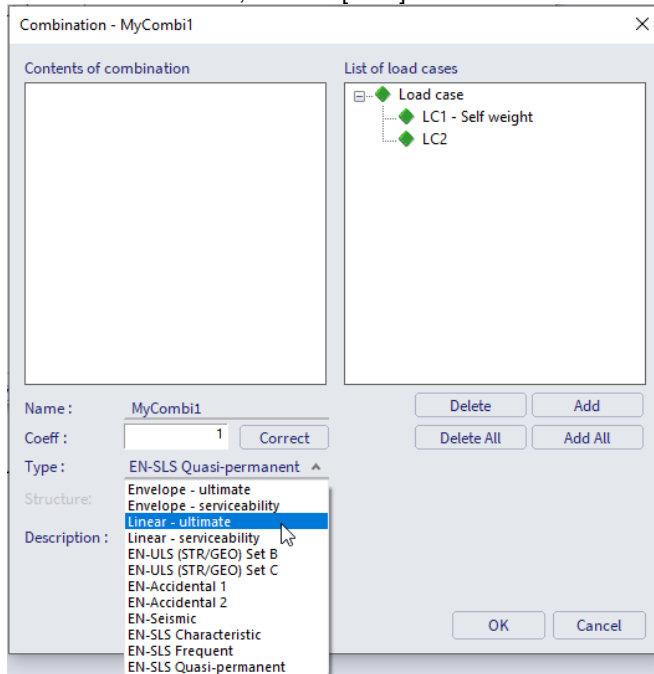

This window contains two lists with load cases. The left list contains the content of the combination you are making, the right list contains all available load cases. You can add a load case by double-clicking in the right list or with the buttons 'Add' and 'Add All'. After setting the load cases you should set the type of combination.

### 3.3.1. Linear combinations

A linear combination is a combination completely defined by yourself. It is a single combination with the selected load cases in it and with coefficients that you set.

Choose the linear combination type (ultimate or serviceability):



Set the coefficients:

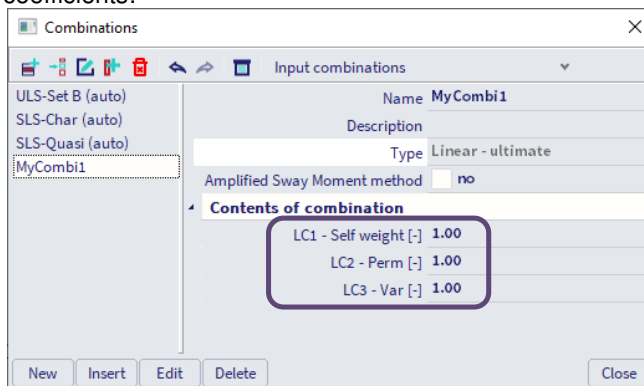

### 3.3.2. Envelope combinations

An envelope combination is a group combination. All possible combinations that can be generated, considering the relations of the load groups, are within this one combination. You still need to set the coefficients.

Choose the combination type (ultimate or serviceability):

Name :	MyCombi2
Coeff :	<input type="text" value="1"/> <input type="button" value="Correct"/>
Type :	Envelope - ultimate

Set the coefficients:

Combinations

Input combinations

ULS-Set B (auto)  
SLS-Char (auto)  
SLS-Quasi (auto)  
MyCombi2

Name MyCombi2  
Description  
Type Envelope - ultimate

**Contents of combination**

LC1 - Self weight [-]	1.00
LC2 - Perm [-]	1.00
LC3 - Var [-]	1.00

**Actions**

Explode to linear >>>

New Insert Edit Delete Close

If you want to see the contents of the 'group' combination press the 'Explode to linear' button. This will split this combination in single 'linear combinations'.

### 3.3.3. Eurocode combinations

A Eurocode combination is a group combination. The relations between the loads and the categories are generated by using the data of the load groups. The categories define the psi factors. They can be found in the Status Bar under the National Annex flag. There you choose Manage annexes, and select the relevant national annex (EN 1990).



This opens the code settings of 1990. Here you can find the table with the psi factors. You can edit the values if needed.

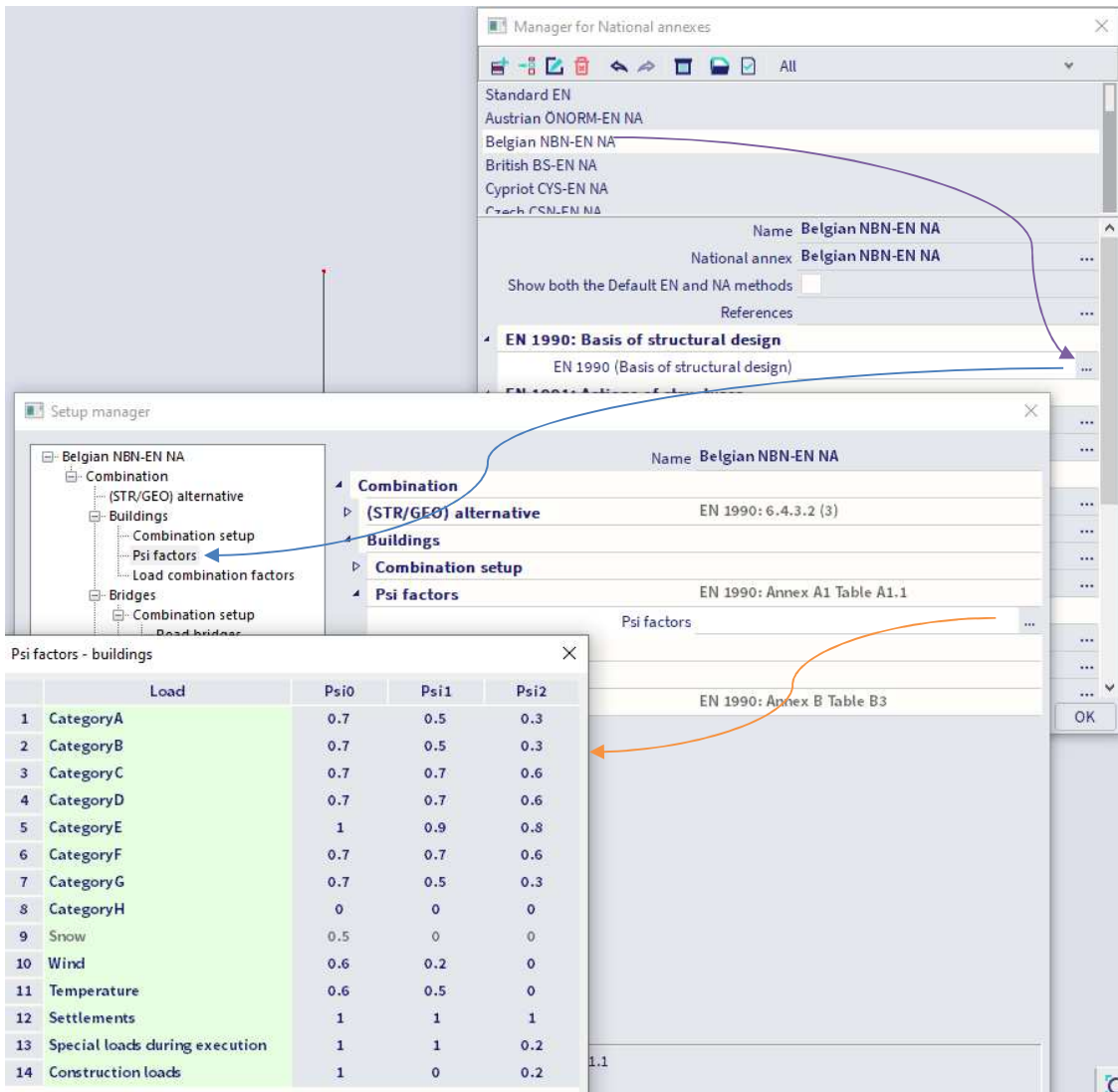

To create a Eurocode combination, select the type EN-ULS or EN-SLS:

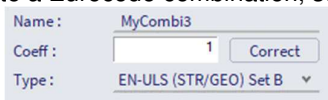

The coefficients cannot be edited. They will be loaded automatically to the load case in the combination.

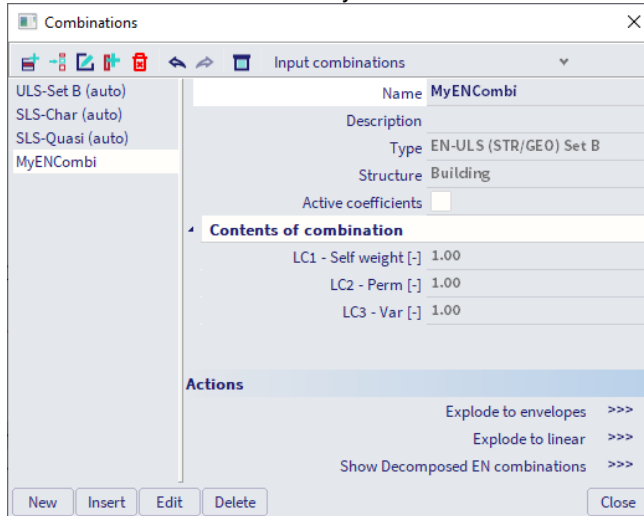

If you want to see the content of the 'group' combination press the 'Explode to linear' button. This will split this combination in single 'linear combinations'.

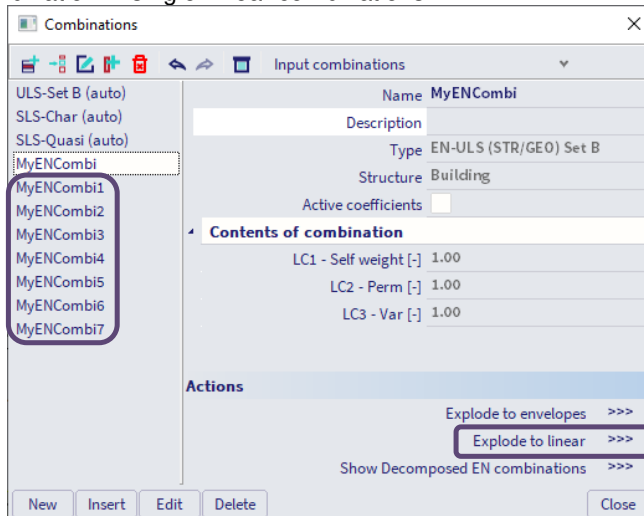

### 3.4. Nonlinear combinations

To perform a nonlinear calculation, nonlinear combinations should be added. You can add a nonlinear combination via the **Main Menu → Libraries → Load cases, combinations**.

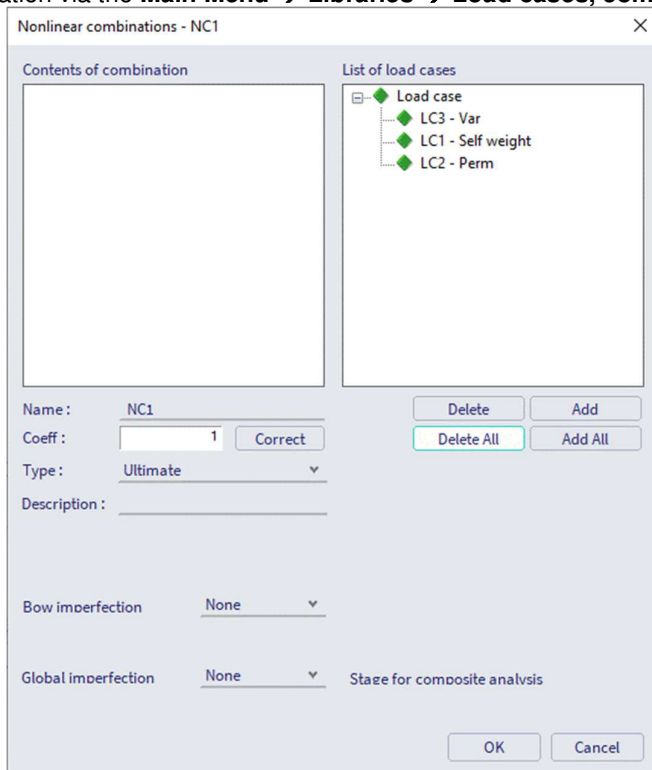

As in the 'Combination' window, you need to select the load cases that should be assigned to the nonlinear combination. A nonlinear combination is a single combination, comparable with a combination of the type 'Linear'. You define the type of the nonlinear combination: 'Ultimate' or 'Serviceability'. At last, a bow and/or global imperfection can be defined. This is only necessary when you perform a second order calculation.

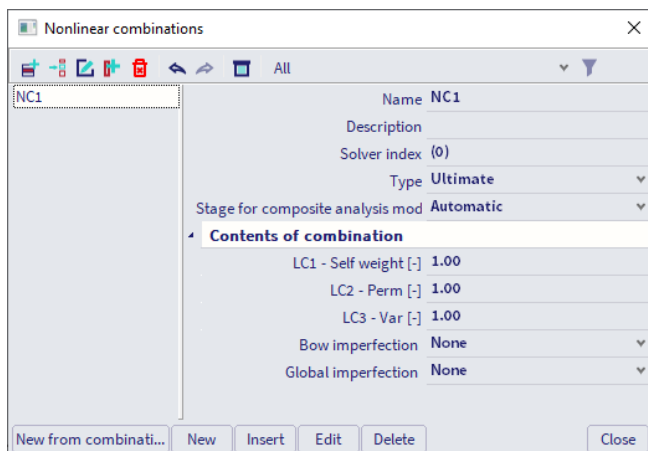

In this window you can set the coefficients and edit the imperfections. There is also a function to automatically create nonlinear combinations from the combinations menu. This can be executed with the button 'New from combination'.

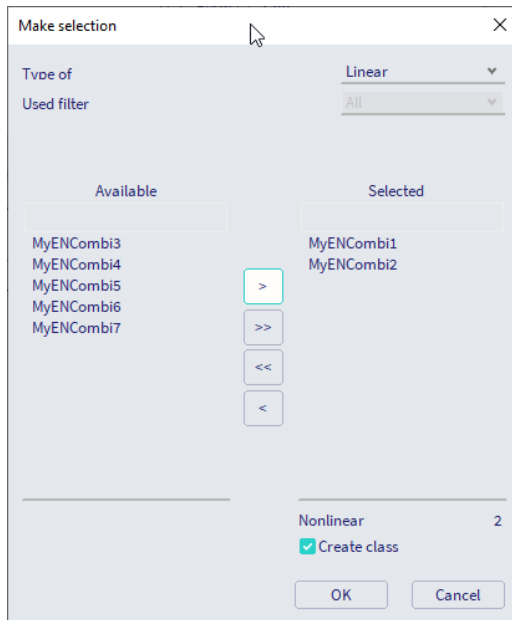

Choose the type of combination (linear or envelope) and select the combinations you want to turn into nonlinear combinations.

### 3.5. Result class

In a result class you can put multiple combinations.

In the 'Result' menu you will see the envelope of these combinations when asking for the result class. Result classes can be found.

Result classes can be found via the **Main Menu → Libraries → Load cases, combinations.**

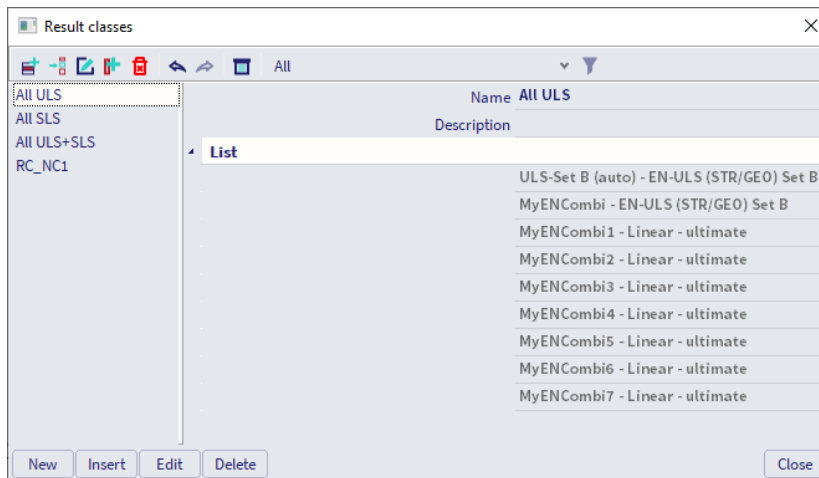

## 3.6. Point force

You can define loads via the Input Panel using workstation Loads.  
You can choose from three types of point loads.

### 3.6.1. Point force in node



You can only place this point force in nodes. You can set following options:



- **Direction:** defines in what direction the force works.
- **Type:** the standard type is 'Force'. You can change it to 'Wind' or 'Snow'. If you change it to wind or snow, the way the option 'Value' is determined changes.
- **Angle:** the point force can be given an angle. This is done by filling in a value for Rx, Ry, Rz.
- **Angle [deg]**
- **Value:** define the magnitude of the force.
- **System:** defines if the direction is following the global axis (GCS) or the local axis (LCS).

### 3.6.2. Point force on beam

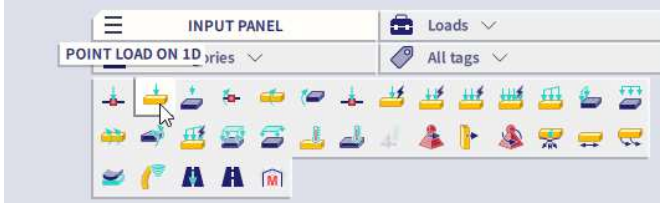

You can place this point force along the length of an element.

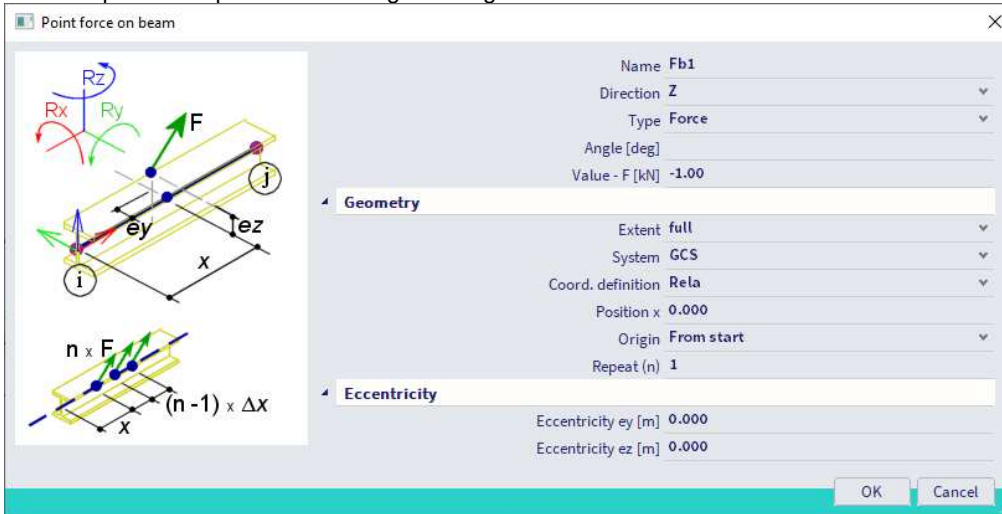

With:

- **Extent:** definition on the full length of the beam or per span.
- **Coord. Definition:** define the position relative (value between 0 and 1) or absolute (value in m).
- **Origin:** definition from the start or the end of the element.
- **Repeat (n):** repeat the point force. If value is higher than one, you should define a distance between point forces.
- **Eccentricity:** gives the point force an eccentricity.



### 3.6.3. Free point force



You can only assign a free point force to a 2D member. You must define the geometry in the **XY**-plane of the current UCS. When you draw the force, it only has an X and Y coordinate. It will be generated on every 2D member that has a point that has this X and Y coordinate. This means that if you have a plate above this point force the force will be generated on this plate as well.

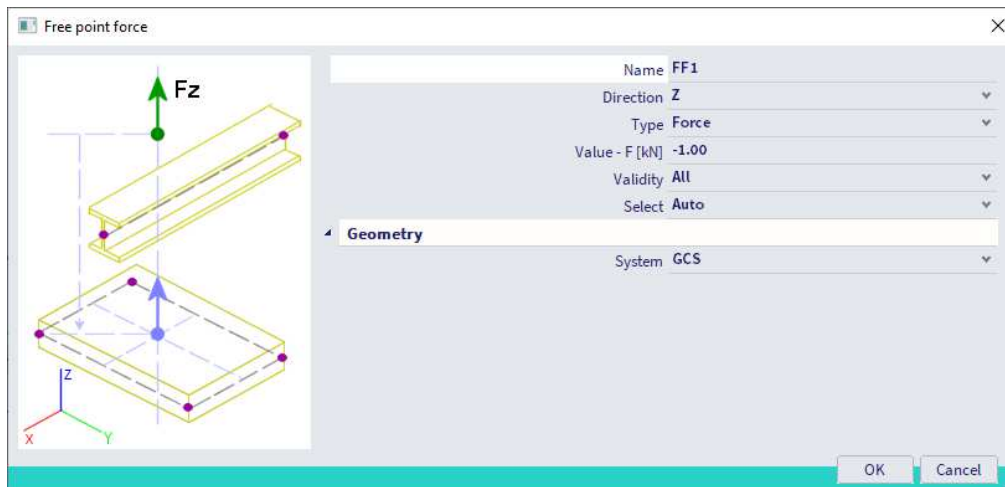
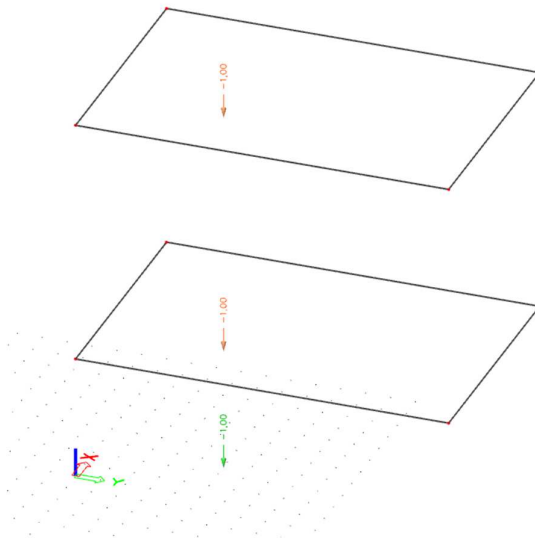

With:

- **Validity:** this setting has an influence on the generation. You can set it to 'All', 'Z+', 'Z-' or '0'. This means that the loads will be generated on all the members or the members with a positive/negative/zero Z coordinate. When the option **'Select'** is defined for the property **'Select'**, the loads will only be generated on the elements which are selected after executing the command **'Update 2D members selection'** in the tab **'Actions'**.
- **Select:** there are 2 options: 'Auto' and 'Select'. 'Auto' means the load is generated on all members. 'Select' means you should select the members to generate the load on.

To view an example of the generation you can select the load and press 'Generate loads' in the property panel.



To switch the view from the generated loads to the original loads, or the other way around, you can delete the generated load OR right click → **View parameters for all** → **Loads/masses**

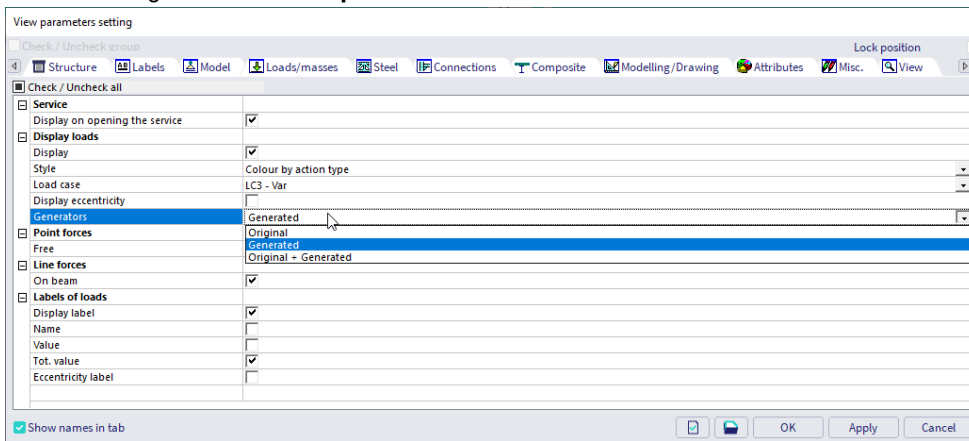

The following pictures provide a graphical representation of all the different validities which can be chosen.

- **Select = Auto, Validity = All**

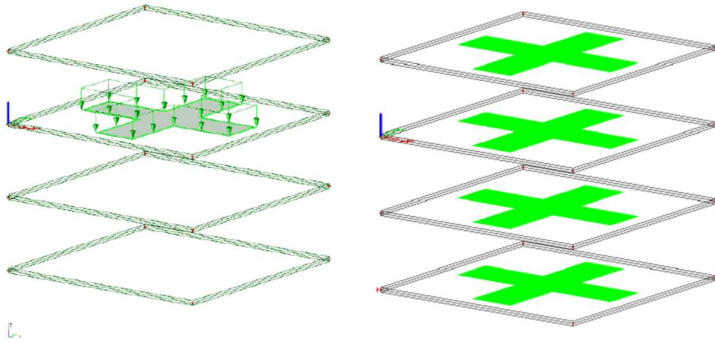

- **Select = Auto, Validity = +Z and -Z**

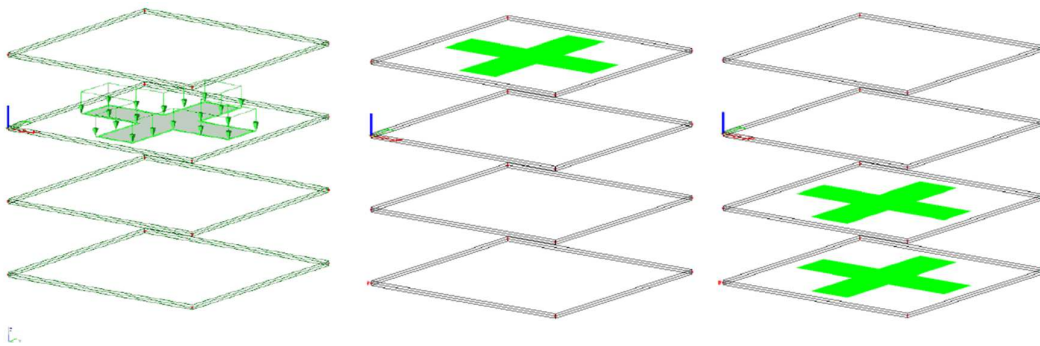

- **Select = Auto, Validity = Z = 0**

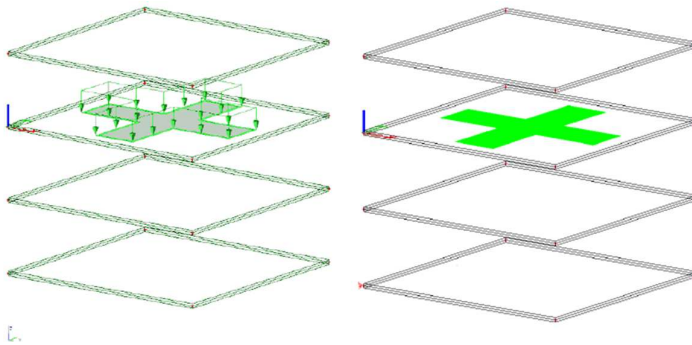

- **Select = Select, Validity = All (Plate 1 and 3 are selected)**

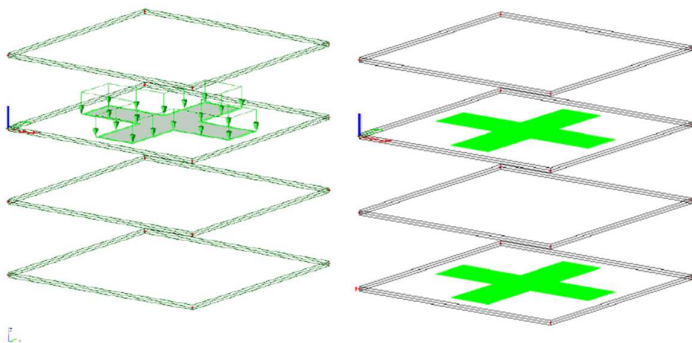

### 3.7. Line force

You can add three types of line forces: 'on beam', 'on 2D member edge' and 'free'.

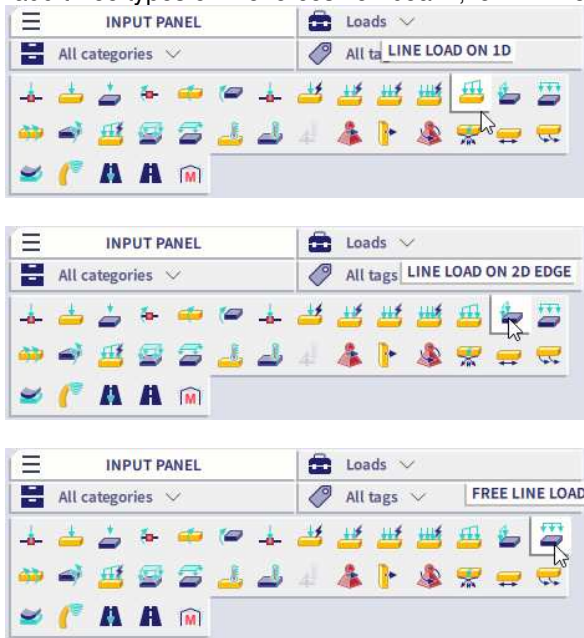

The settings for line forces are the same as for point forces. The only extra setting is the length of the line force. This can be set to relative (value between 0 and 1) or absolute.

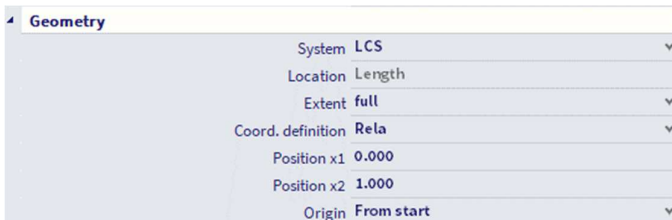

### 3.8. Surface load

Next to point forces and line forces there are also surface loads. You can choose between two types of surface loads: 'on 2D member' and 'free'.



The settings are the same as for the load types above.

## Chapter 4: Calculation

### 4.1. Mesh

As default setting, a 1D element consists of 1 mesh element and a 2D element has an average mesh element of 1m.

You can change these settings in **Main Menu → Tools → Calculation & Mesh** OR when starting the calculation.

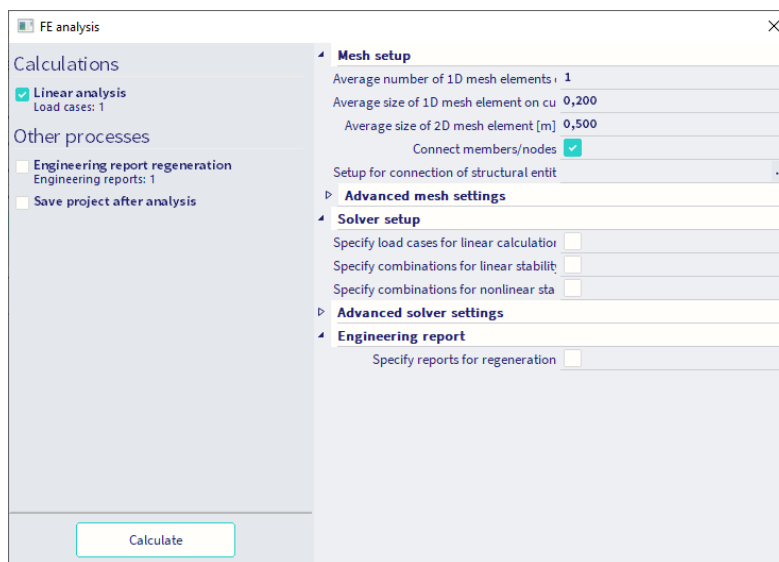
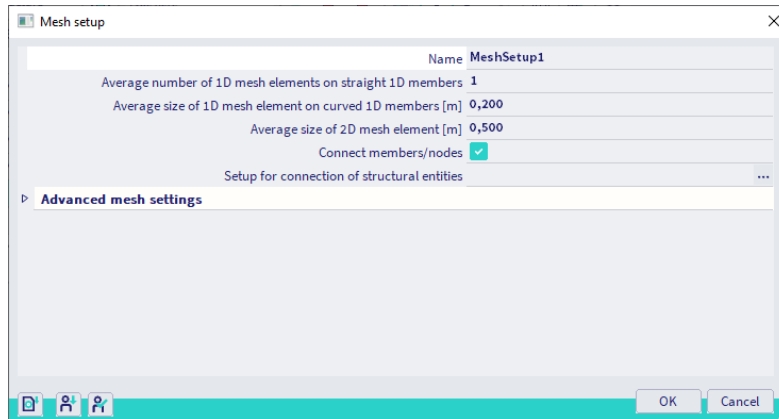

This setting has an influence on the accuracy of the results and on the speed of the calculation.

The mesh can be viewed by either going to 'Set view parameters for all', after right mouse click in the graphical screen, or by going to the **Viewbar → Other options → View settings for all entities**. Then select:

- Structure tab → Mesh → Draw mesh
- Labels tab → Mesh → Display label

## 4.2. Calculation / Solver

You can start the calculation either by clicking on the calculation shortcut in the Process Toolbar,



or via **Main Menu → Tools → Calculation & Mesh → Calculate mesh**,  
or by using the Ctrl-Shift-F5 shortcut.

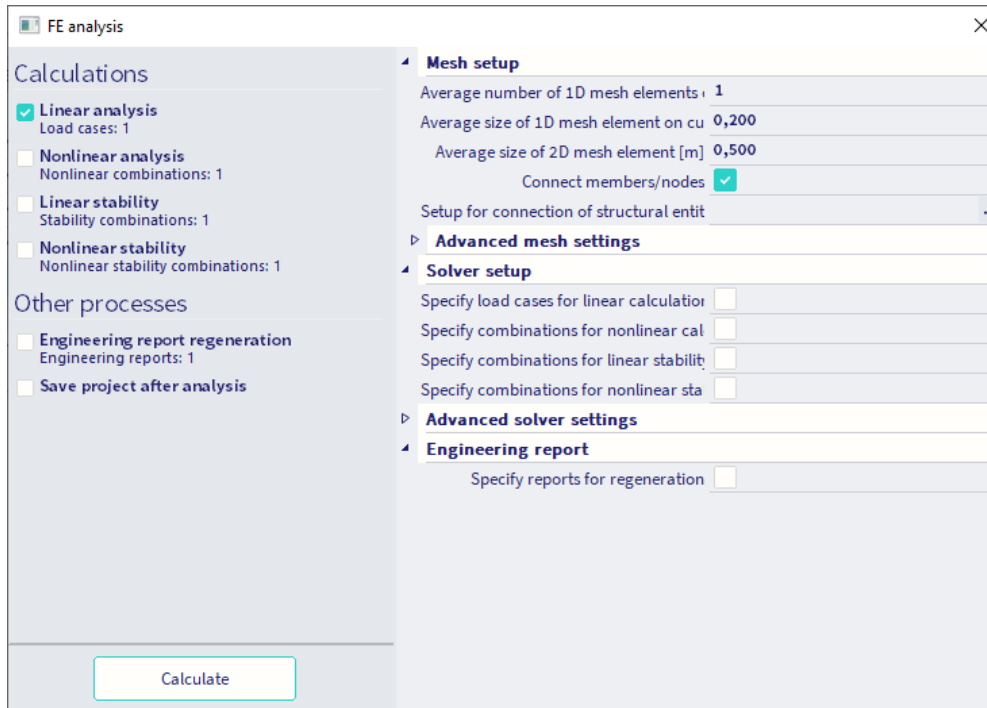

In the top left you can choose desired type(s) of analyses by checking/unchecking the boxes.

**NOTE: you can turn on the option 'Connect members/nodes' so the program will automatically execute this function before starting the calculation.**

## Chapter 5: Results

### 5.1. Requesting results

After you perform the calculation, then the Results will be available in the Main Menu. You can ask for the following results:

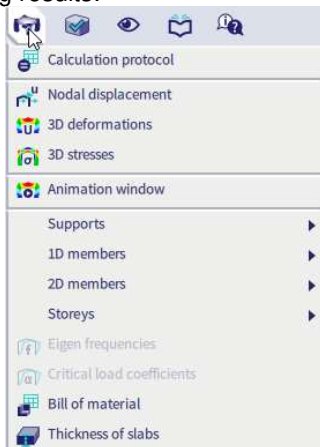

#### 5.1.1. Calculation protocol

In the calculation protocol you can check the equilibrium between the inputted loads and the acting reactions.

Calculation protocol				
<b>Linear calculation</b>				
Number of 2D elements				150
Number of 1D elements				107
Number of mesh nodes				196
Number of equations				1176
Bending theory			Mindlin	
Load cases			BG1, BG2	
Start of calculation				19.11.2018 00:50
End of calculation				19.11.2018 00:50
<b>Sum of loads and reactions</b>				
Load case	Value	X [kN]	Y [kN]	Z [kN]
BG1	loads	0,00	0,00	-1795,51
	reaction in nodes	0,00	0,00	1795,51
	reaction on lines	0,00	0,00	0,00
	contact 1D	0,00	0,00	0,00
	contact 2D	0,00	0,00	0,00
BG2	loads	0,00	0,00	-300,00
	reaction in nodes	0,00	0,00	300,00
	reaction on lines	0,00	0,00	0,00
	contact 1D	0,00	0,00	0,00
	contact 2D	0,00	0,00	0,00



### 5.1.2. Nodal displacement

This result gives you the displacement and rotation of all the nodes in the structure. This is the purest result out of the FEM analysis.

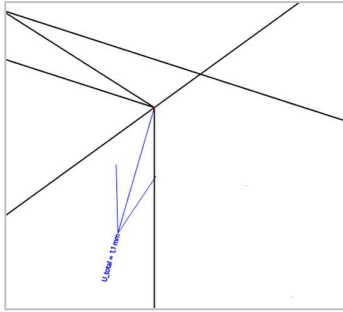

### 5.1.3. 3D Results

There are two types of 3D results: '**3D displacement**' and '**3D stress**'. In order to generate these results, the 1D results of 1D members and 2D results of 2D members are converted to 3D results. This is done with transformation formulas. These results are not calculated in the calculation by the solver but are generated by the post processor. Due to this transformation, the generation of results may take some time, depending on the size of the structure (and the refinement of the mesh).

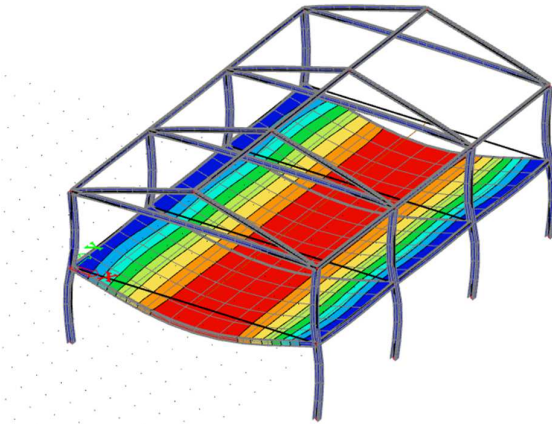

### 5.1.4. Results per component

For each component there is an item in the result menu: **supports**, **beams (1D members)** and **2D members**. For each of these components there are detailed results available. These results are calculated during the calculation by the solver and take no additional time to generate. The difference with the 3D results is that these results are viewed in 1D for beams and in 2D for 2D Members.

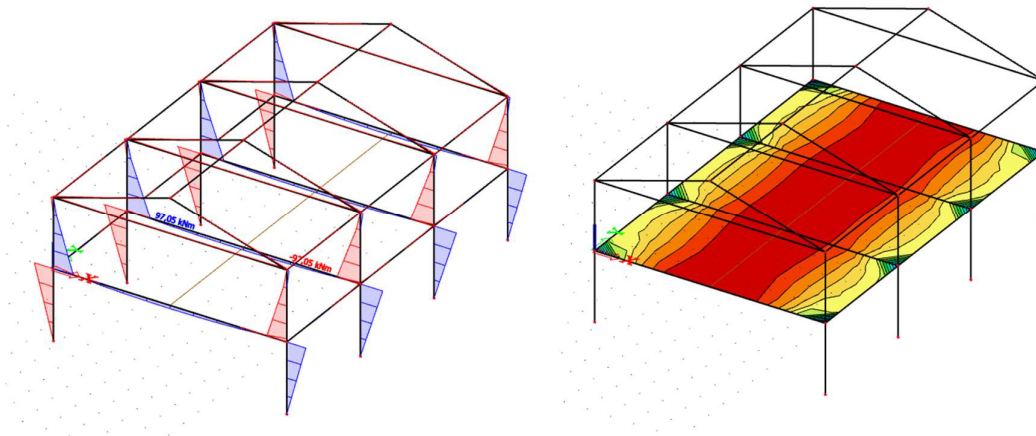



### 5.1.5. Bill of material

In the bill of material, you will find information concerning the **mass**, **surface** and **volume** of the used materials in the project.

**Bill of material**

Selection: All  
Type of sorting: Material

**Summary**

Material	Mass [kg]	Surface [m <sup>2</sup> ]	Volume [m <sup>3</sup> ]
Steel	183028,2	353,413	2,3316e+01
Total	183028,2	353,413	2,3316e+01

Note: Value 'Surface' represents for 1D members the total exposed surface area, while for 2D members it corresponds only to the surface area of the centroidal plane.

**Steel (1D)**

Material	Density [kg/m <sup>3</sup> ]	Mass [kg]	Surface [m <sup>2</sup> ]	Volume [m <sup>3</sup> ]
S 235	7850,0	6403,2	203,413	8,1570e-01
Total		6403,2	203,413	8,1570e-01

**Steel (2D)**

Material	Density [kg/m <sup>3</sup> ]	Mass [kg]	Surface [m <sup>2</sup> ]	Volume [m <sup>3</sup> ]
S 235	7850,0	176625,0	150,000	2,2500e+01
Total		176625,0	150,000	2,2500e+01

### 5.1.6. Thickness of slabs

This function allows you to show a graphical representation of the thicknesses of all 2D elements in your model. With the 'drawing setup 2D' you can chose between different lay-outs of which 'thickness of slabs' which generates a colour for each individual thickness. If you would chose for 'Smooth' for example, a gradual legend will be applied to show the thicknesses. This last option is automatically used whenever there are elements in the selection with a variable thickness.

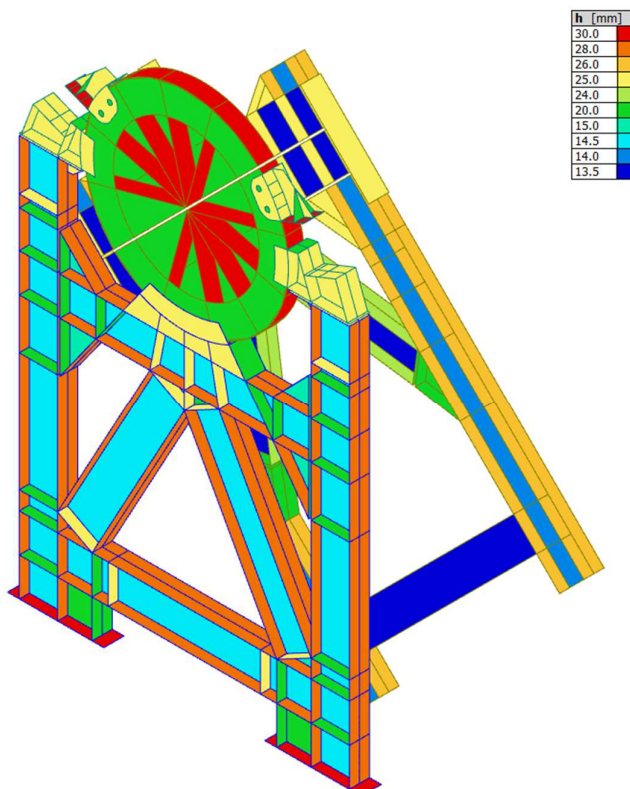

### 5.1.7. Setting the properties menu

After you selected a result type, you need to set some parameters in the property panel. As an example, the property panel of the '2D internal forces' will be taken. Other results have similar options in the property panel.

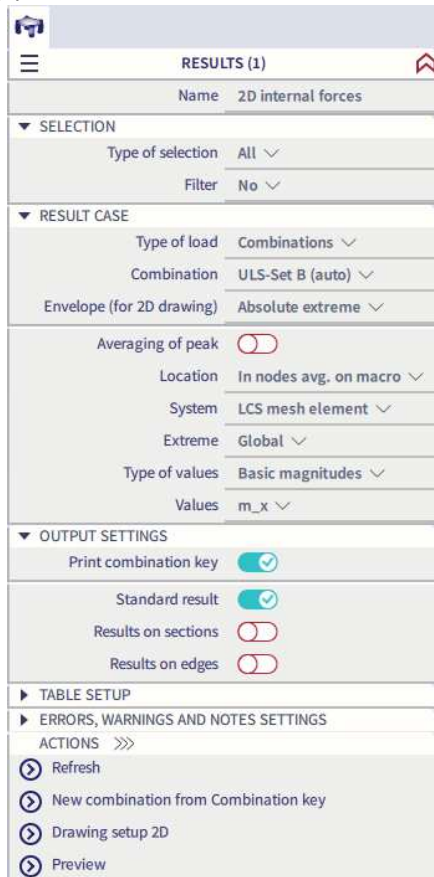

- **Type of selection:** view results on the complete structure or on a selection of it.
- **Filter:** filter on material, wildcard, layer or thickness.
- **Type of load:** choose the load case, combination or result class.
- **Envelope:** show maximum, minimum or absolute extreme values. Absolute extreme show you the biggest absolute value.

- **Location:** the finite elements mesh in SCIA Engineer exists of linear 3- and/or 4-angular elements. Per mesh element 3 or 4 results are calculated, one in each node. When you ask for the results on 2D members, the option 'Location' in the property panel gives you the possibility to display these results in 4 ways.

- **In nodes, no average**

All result values are considered, there is no averaging. In each node are therefore the 4 values of the adjacent mesh elements shown. If these 4 results differ a lot from each other, it is an indication that the chosen mesh size is too large. This display of results therefore gives you a good idea of the discretisation error in the calculation model.

12	16	24	30
9	18	25	31
11	16	24	29
9	17	24	30

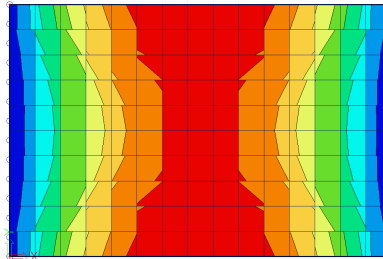

- **In centres**

Per finite element, the mean value of the results in the nodes of that element is calculated. Since there is only 1 result per element, the display of isobands becomes a mosaic. The course over a section is a curve with a constant step per mesh element.

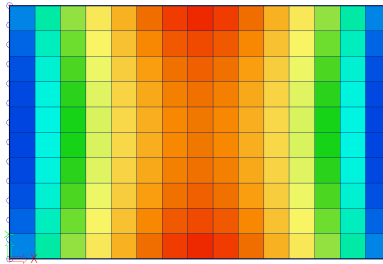
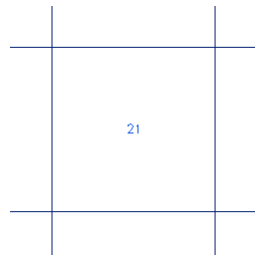

- **In nodes, average**

The values of the results of adjacent finite elements are averaged in the common node. Because of this, the graphical display is a smooth course of isobands.

In certain cases, it is not permissible to average the values of the results in the common node:

- At the transition between 2D members (plates, walls, shells) with different local axes;
- If a result is discontinuous, like the shear force at the place of a line support in a plate. The peaks will disappear completely by the averaging of positive and negative shear forces.

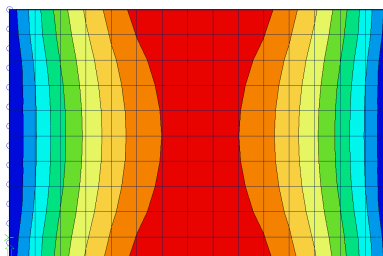
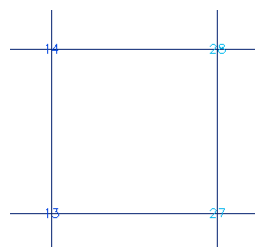

○ **In nodes, average on macro**

The values of the results are averaged per node *only* over mesh elements which belong to the same 2D member and which have the same directions of their local axes. This resolves the problems mentioned at the option 'In nodes, average'.

14	14	28	28
14	14	28	28
13	13	27	27
13	13	27	27

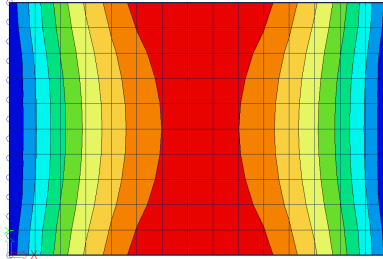

- **System:** direction according to: 'LCS of the mesh' or 'LCS of the element'.
- **Extreme:** you can set this setting on 'Global', 'Member' or 'Mesh'. 'Global' means that only the maximum value of the complete model is shown. For 'Member' the maximum per member is shown. For 'Mesh' the maximum per mesh element is shown.
- **Type of values:** there are three types of values: 'Basic magnitudes', 'Principal magnitudes' and 'Design values'.
  - **Basic magnitudes = Characteristic values**

▪ **Beams 1D**

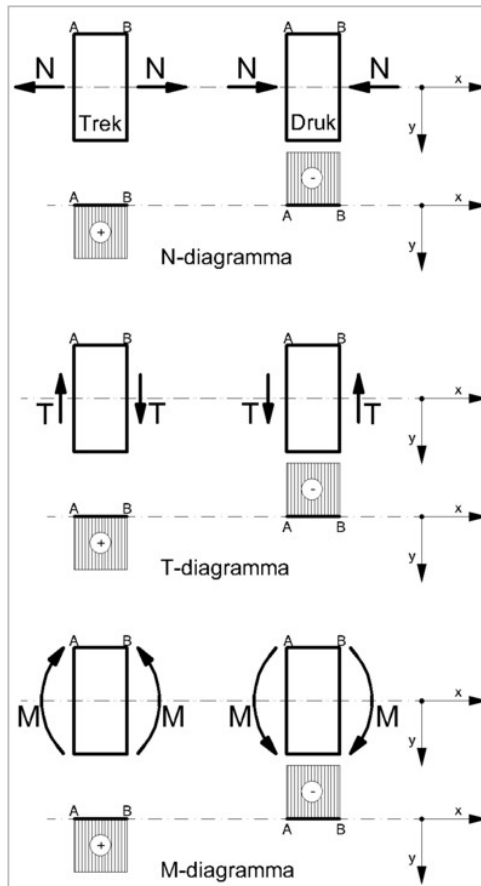

- **Bending (plates, shells)**

- Bending moments  $m_x, m_y$

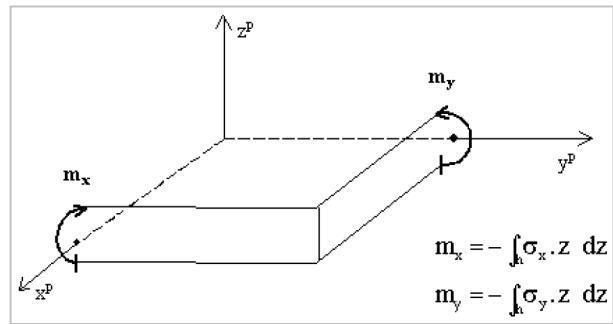

- Torsion moment  $m_{xy}$

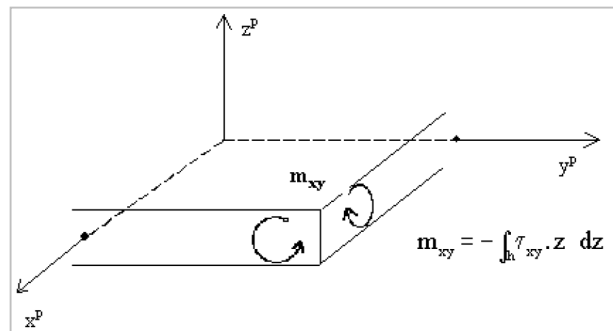

- Shear forces  $q_x, q_y$  ( $=v_x, v_y$ )

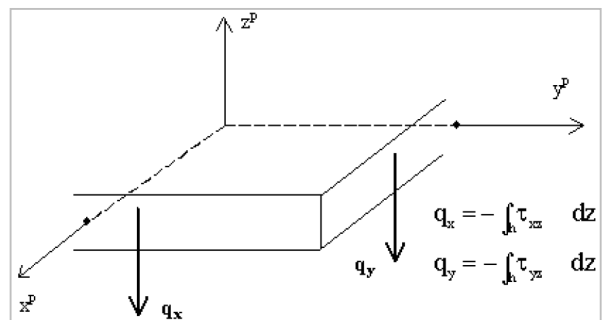

- **Membrane effects (walls, shells)**

- Membrane forces  $n_x, n_y$

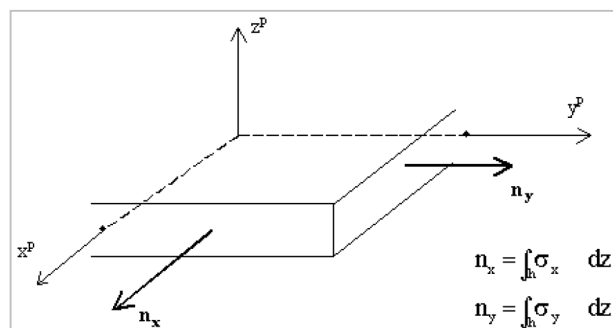

- Shear force  $q_{xy}$  ( $=n_{xy}$ )

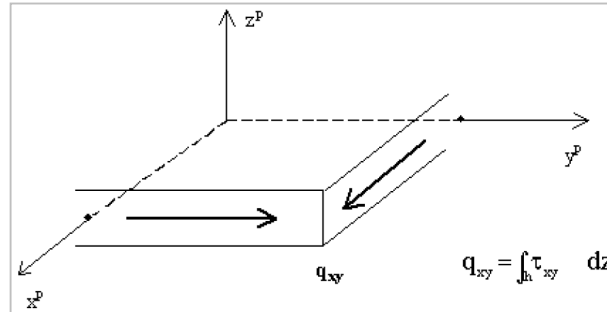

- **Principal magnitudes**

The principal magnitudes give the results according to the axes of the directions of the largest stresses (principal directions). These directions are defined with the help of the Mohr's circle.

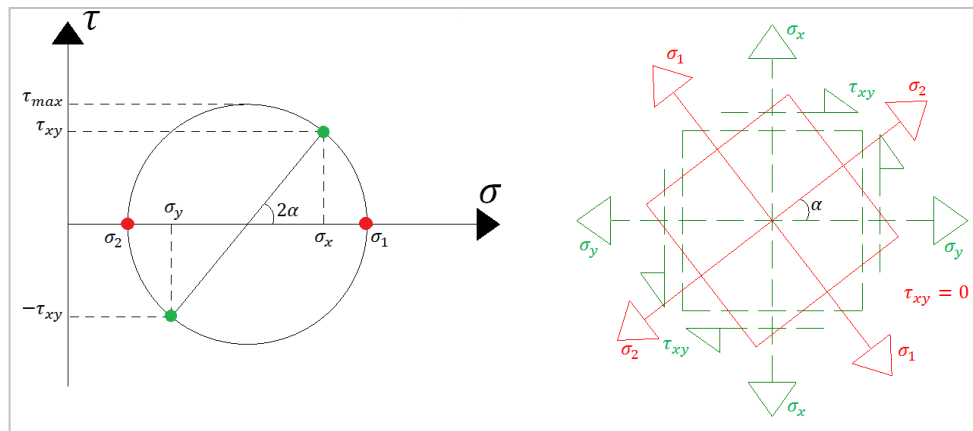

- **Elementary design magnitudes = Design values**

To derive the dimensional magnitudes from the basic magnitudes, formulas of the Eurocode are used:

$m_{xD+}$  design moment in direction of local axis x for reinforcement on positive surface

$$m_x + |m_{xy}| \text{ for } \begin{cases} m_x \leq m_y \text{ and } m_x \geq -|m_{xy}| \\ m_x > m_y \text{ and } m_y \geq -|m_{xy}| \end{cases}$$

$$m_x + \frac{m_{xy}^2}{|m_y|} \text{ for } m_x > m_y \text{ and } m_y < -|m_{xy}|$$

$$0 \text{ for } m_x \leq m_y \text{ and } m_x < -|m_{xy}|$$

$m_{xD-}$  design moment in direction of local axis x for reinforcement on negative surface

$$m_x + |m_{xy}| \text{ for } \begin{cases} m_x \leq m_y \text{ and } m_x \geq -|m_{xy}| \\ m_x > m_y \text{ and } m_y \geq -|m_{xy}| \end{cases}$$

$$m_x + \frac{m_{xy}^2}{|m_y|} \text{ for } m_x > m_y \text{ and } m_y < -|m_{xy}|$$

$$0 \text{ for } m_x \leq m_y \text{ and } m_x < -|m_{xy}|$$

$m_{yD+}$  design moment in direction of local axis y for reinforcement on positive surface

$$m_x + |m_{xy}| \text{ for } \begin{cases} m_x \leq m_y \text{ and } m_x \geq -|m_{xy}| \\ m_x > m_y \text{ and } m_y \geq -|m_{xy}| \end{cases}$$

$$m_x + \frac{m_{xy}^2}{|m_y|} \text{ for } m_x > m_y \text{ and } m_y < -|m_{xy}|$$

$$0 \text{ for } m_x \leq m_y \text{ and } m_x < -|m_{xy}|$$

$m_{yD-}$  design moment in direction of local axis y for reinforcement on negative surface

$$m_x + |m_{xy}| \text{ for } \begin{cases} m_x \leq m_y \text{ and } m_x \geq -|m_{xy}| \\ m_x > m_y \text{ and } m_y \geq -|m_{xy}| \end{cases}$$

$$m_x + \frac{m_{xy}^2}{|m_y|} \text{ for } m_x > m_y \text{ and } m_y < -|m_{xy}|$$

$$0 \text{ for } m_x \leq m_y \text{ and } m_x < -|m_{xy}|$$

$m_{cD+}$  complementary design moment in the concrete on positive surface

$$-2|m_{xy}| \text{ for } \begin{cases} m_x \leq m_y \text{ and } m_x \geq -|m_{xy}| \\ m_x > m_y \text{ and } m_y \geq -|m_{xy}| \end{cases}$$

$$m_x - \frac{m_{xy}^2}{|m_x|} \text{ for } m_x \leq m_y \text{ and } m_x < -|m_{xy}|$$

$$m_y - \frac{m_{xy}^2}{|m_y|} \text{ for } m_x > m_y \text{ and } m_x < -|m_{xy}|$$

$m_{cD-}$  complementary design moment in the concrete on negative surface

$$-2|m_{xy}| \text{ for } \begin{cases} m_x \leq m_y \text{ and } m_x \geq -|m_{xy}| \\ m_x > m_y \text{ and } m_y \geq -|m_{xy}| \end{cases}$$

$$m_x - \frac{m_{xy}^2}{|m_x|} \text{ for } m_x \leq m_y \text{ and } m_x < -|m_{xy}|$$

$$m_y - \frac{m_{xy}^2}{|m_y|} \text{ for } m_x > m_y \text{ and } m_x < -|m_{xy}|$$

$n_{xD}$  design force in x direction

$$n_x + |n_{xy}| \text{ for } \begin{cases} n_x \leq n_y \text{ and } n_x \geq -|n_{xy}| \\ n_x > n_y \text{ and } n_y \geq -|n_{xy}| \end{cases}$$

$$n_x + \frac{n_{xy}^2}{|n_y|} \text{ for } n_x > n_y \text{ and } n_y < -|n_{xy}|$$

$$0 \text{ for } n_x \leq n_y \text{ and } n_x < -|n_{xy}|$$

$n_{yD}$  design force in y direction

$$n_y + |n_{xy}| \text{ for } \begin{cases} n_x \leq n_y \text{ and } n_x \geq -|n_{xy}| \\ n_x > n_y \text{ and } n_y \geq -|n_{xy}| \end{cases}$$

$$n_y + \frac{n_{xy}^2}{|n_x|} \text{ for } n_x \leq n_y \text{ and } n_x < -|n_{xy}|$$

$$0 \text{ for } n_x > n_y \text{ and } n_y < -|n_{xy}|$$

$n_{cD}$  design force in concrete

$$-2|n_{xy}| \text{ for } \begin{cases} n_x \leq n_y \text{ and } n_x \geq -|n_{xy}| \\ n_x > n_y \text{ and } n_y \geq -|n_{xy}| \end{cases}$$

$$-|n_x| - \frac{n_{xy}^2}{|n_x|} \text{ for } n_x \leq n_y \text{ and } n_x < -|n_{xy}|$$

- **Drawing setup 2D:** In this window you can configure how you want to see the results (isobands, isolines, numbers, ...). You can also set a maximum and minimum value.

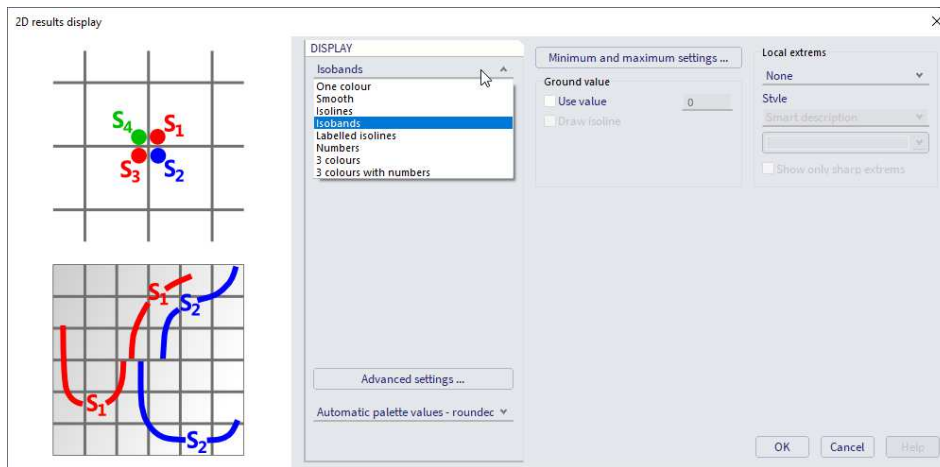

Isobands

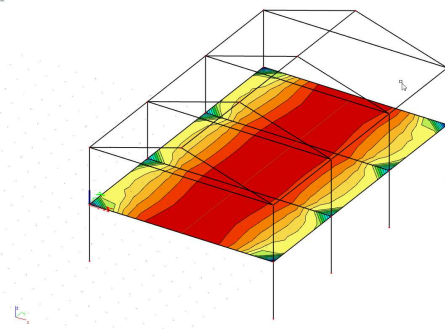

Numbers

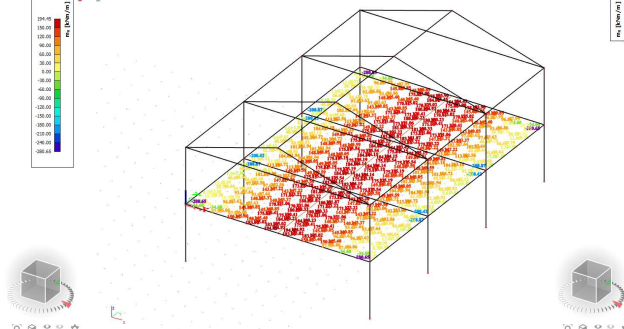

## 5.2. Results table

You can also ask for the results in a table. You can open the results table by clicking on the 'Results table' in the property panel.



Name	Mesh	x [m]	y [m]	z [m]	Case	mx [kNm/m]	my [kNm/m]	mxy [kNm/m]	vx [kN/m]	vy [kN/m]	nx [kN/m]	ny [kN/m]	mxy [kN/m]
1	S1 Element: 1661; Node: 11	10,000	7,000	4,000	CO1/1	-52,08	-112,82	0,86	274,51	-251,79	590,52	-64,23	-11,42
2	S1 Element: 509; Node: 579	7,250	2,250	4,000	CO1/2	16,28	50,23	-0,20	-0,07	5,09	-86,66	-30,14	-4,63
3	S1 Element: 1661; Node: 11	10,000	7,000	4,000	CO1/3	-52,04	-112,86	0,89	274,90	-251,82	589,56	-64,28	-10,95
4	S1 Element: 680; Node: 732	15,000	2,750	4,000	CO1/3	0,20	55,23	-2,87	-1,67	48,28	0,40	164,80	-0,30
5	S1 Element: 1680; Node: 12	15,000	7,000	4,000	CO1/4	-28,54	-96,60	-20,43	-258,76	-88,59	319,68	-52,93	129,01
6	S1 Element: 1621; Node: 9	0,000	7,000	4,000	CO1/4	-28,16	-95,12	19,99	255,90	-82,33	314,14	-114,09	-109,92
7	S1 Element: 5620; Node: 18	5,000	28,000	4,000	CO1/5	-51,92	-112,00	1,00	-276,68	251,42	590,29	-63,17	-18,59
8	S1 Element: 5641; Node: 19	10,000	28,000	4,000	CO1/2	-51,92	-112,00	-0,96	276,57	251,45	590,66	-63,05	18,73
9	S1 Element: 1660; Node: 11	10,000	7,000	4,000	CO1/5	-50,60	-112,48	-1,35	-253,98	-252,37	597,11	-61,04	30,49



### 5.3. Results preview

You can view the results as well in the preview. The preview shows you the table that is generated by the engineering report.



#### 2D internal forces

Linear calculation  
 Combination: CO1  
 Extreme: Global  
 Selection: All  
 Location: In nodes avg. on macro. System: LCS mesh element  
**Basic magnitudes**

Name	Mesh	Position [m]	Case	m		V		n	
				$m_x$ [kNm/m]	$m_y$ [kNm/m]	$V_x$ [kN/m]	$V_y$ [kN/m]	$n_x$ [kN/m]	$n_y$ [kN/m]
E1	Element: 1 Node: 1	0,000 0,000 3,000	CO1/1	<b>-280,65</b> -78,80	-40,44	<b>682,47</b> 164,53	<b>11,63</b> 2,59	<b>4,66</b>	
E1	Element: 5 Node: 180	5,000 0,000 3,000	CO1/1	<b>194,45</b> 4,42	0,00	0,00 9,82	2,00 -0,05	0,00	
E1	Element: 20 Node: 33	10,000 2,000 3,000	CO1/1	13,08 <b>64,26</b>	5,18	-50,14 24,57	-0,15 -2,21	0,01	
E1	Element: 8 Node: 186	8,000 0,000 3,000	CO1/1	87,99 6,62	<b>-42,57</b>	-187,51 27,47	4,30 0,23	-0,08	
E1	Element: 2 Node: 66	2,000 0,000 3,000	CO1/1	87,99 6,62	<b>42,57</b>	187,51 27,47	4,30 0,23	0,08	
E1	Element: 41 Node: 5	0,000 5,000 3,000	CO1/1	-208,87 -194,48	39,17	545,00 <b>-319,78</b>	6,42 2,75	-3,45	
E1	Element: 101 Node: 8	10,000 10,000 3,000	CO1/1	-208,87 <b>-194,48</b>	39,17	-545,00 <b>319,78</b>	6,42 2,75	-3,45	
E1	Element: 1 Node: 57	0,000 1,000 3,000	CO1/1	8,72 42,68	-15,27	-249,11 107,95	<b>-4,26</b> <b>-3,30</b>	-1,47	
E1	Element: 51 Node: 6	10,000 5,000 3,000	CO1/1	-200,42 -192,12	36,89	-542,29 293,27	6,76 <b>3,27</b>	-3,74	
E1	Element: 10 Node: 2	10,000 0,000 3,000	CO1/1	-280,65 -78,80	40,44	<b>-682,47</b> 164,53	11,63 2,59	<b>-4,66</b>	

Name	Combination key
CO1/1	1.35*BG1 + 1.50*BG2

### 5.4. Section on 2D member

You can find the 'Section on 2D' command in the Calculation & Results workstation of the Input Panel:

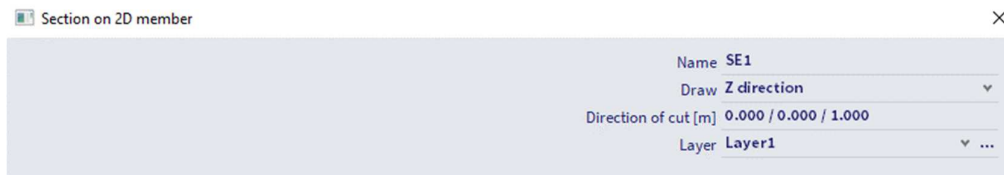

- **Draw:** determines the direction of the result which is drawn on the section.
- **Direction of cut:** defines the direction of the cut that will be made by a vector X/Y/Z. For example, 0/0/1 is a cut in the Z direction.

To view the results on the section you need to check the 'Results on sections' in the property panel when you ask for a result.

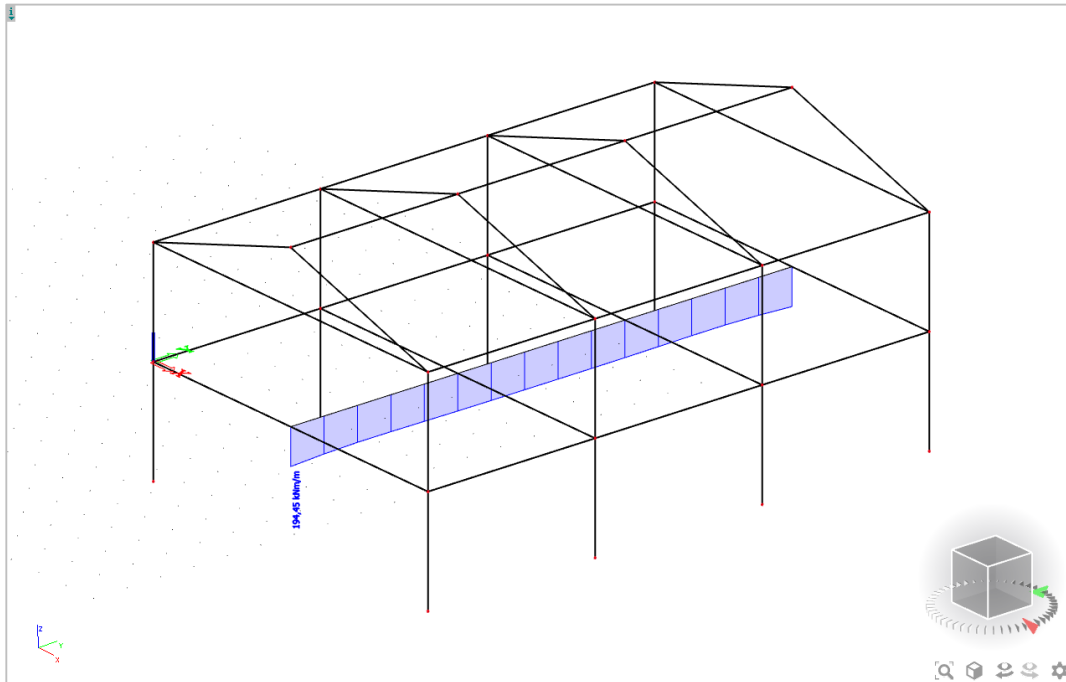
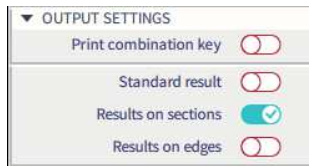

## 5.5. Averaging strip

An averaging strip averages peak values over a zone.

You can find the averaging strip in the Calculation & Results workstation of the Input Panel:

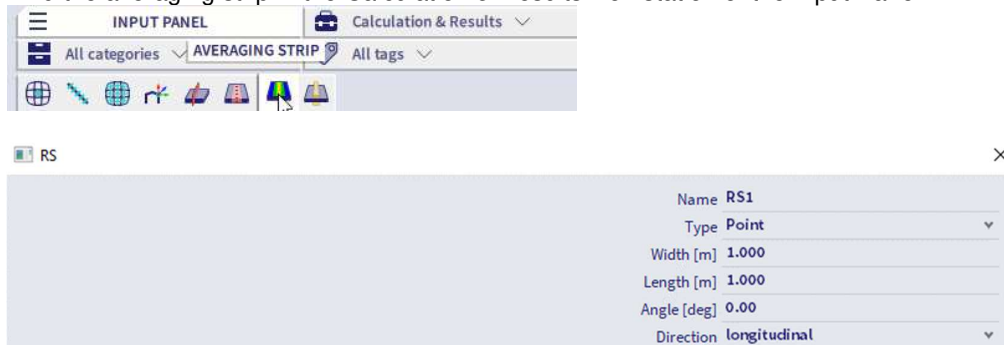

- **Type:** you can choose between a point or a strip.
- **Dimensions:** here you need to set the dimensions of the point/strip.

- **Direction:**

- 1) Direction = Longitudinal

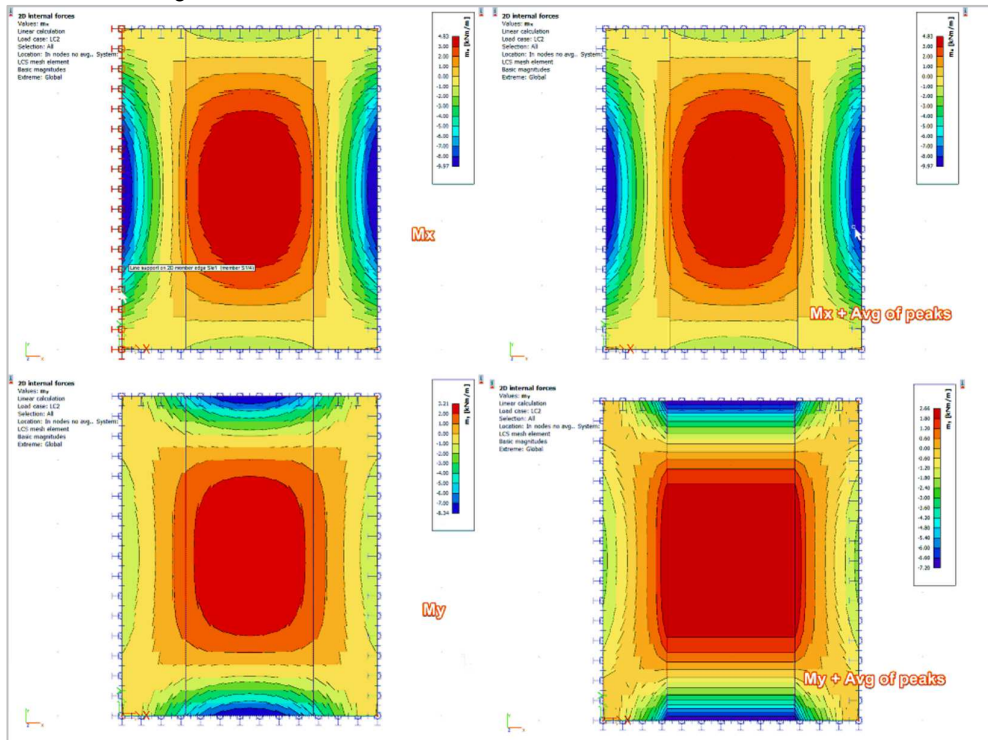

Longitudinal means that the averaging is done in the longitudinal direction of the strip. In the example above this is the y-direction. This means that the averaging is done for  $m_y$ . The values  $m_y$  are averaged in the x-direction.

- 2) Direction = perpendicular

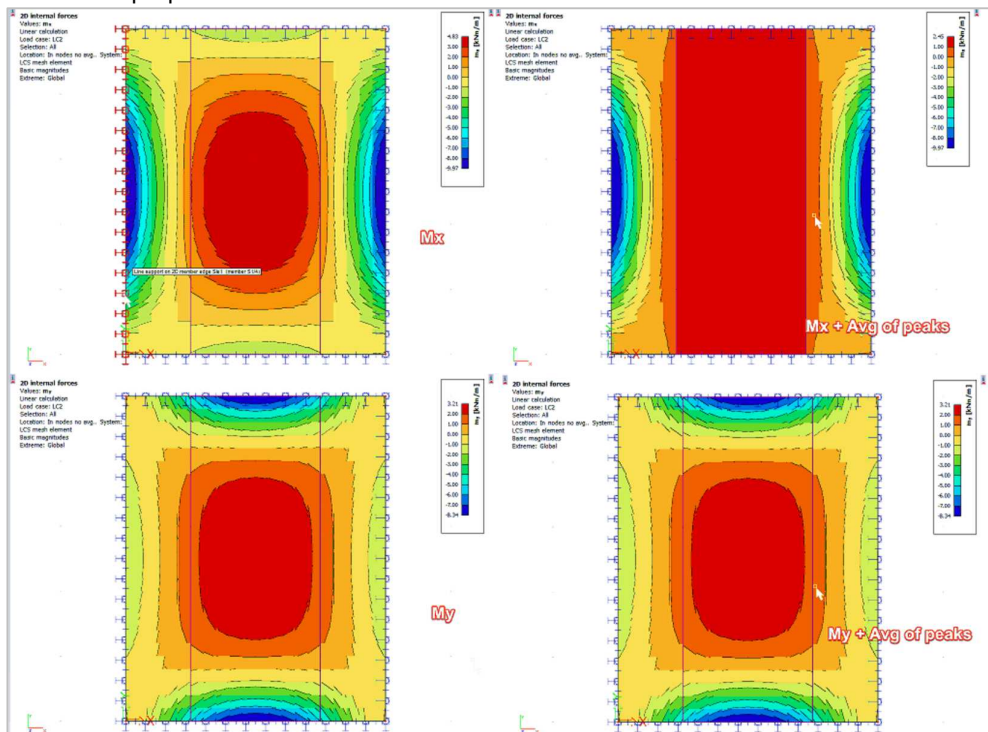

Perpendicular means that the averaging is done perpendicular to the longitudinal direction of the strip. In the example above this is the x-direction. This means that the averaging is done for  $m_x$ . The values  $m_x$  are averaged in the y-direction.

3) Direction = Both

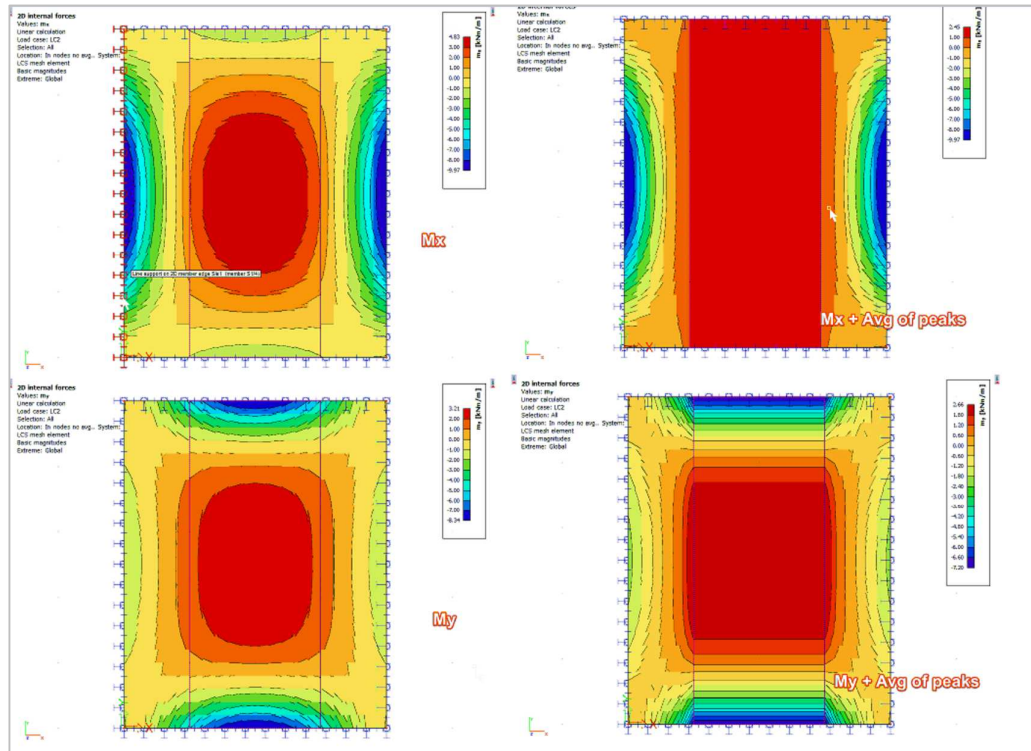

Both means that the averaging is done in both directions of the averaging strip. This means the values are averaged for  $m_x$  as well as  $m_y$  in the direction perpendicular to  $m_x$  and  $m_y$ .

To activate the averaging strip you need to check the option 'Averaging of peak' in the property panel.

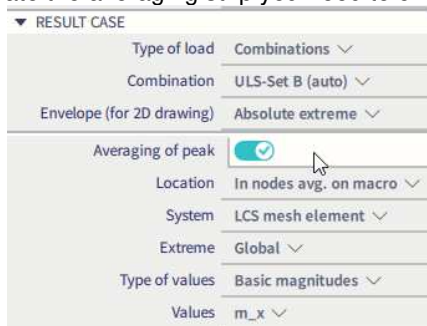

## 5.6. Integration strip / integration member

An integration strip is a strip which is defined on a 2D member. On this strip you can ask results as if it is a 1D member.

An integration member works in 3D, so the results on multiple 2D members will be given on the strip as if it is a 1D member.

You can find both functions in the Calculation & Results workstation of the Input Panel:

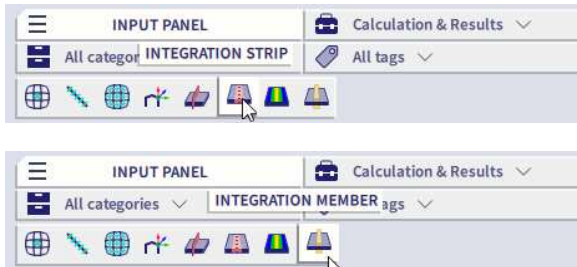

Set the width of the integration strip:

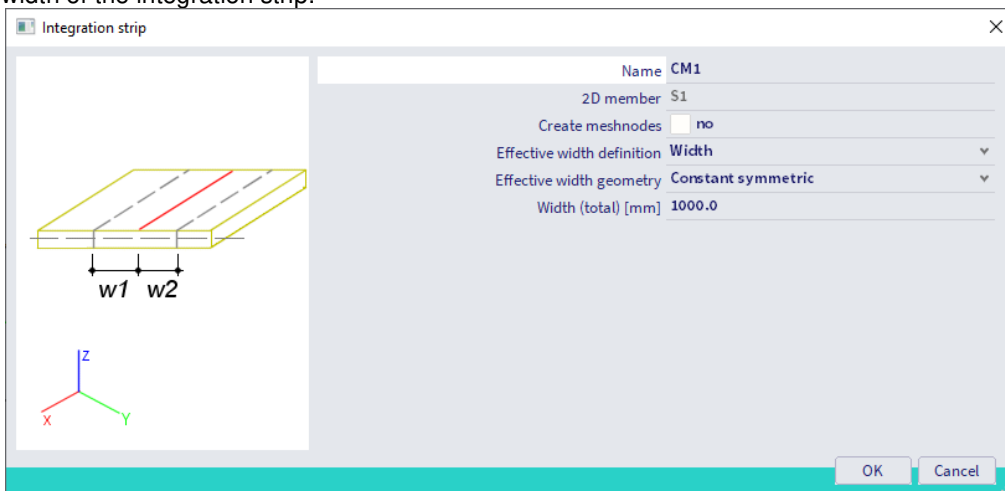

Go to **Main Menu** → **Results** → **1D Members** → **Internal forces**, and check the option 'Integration strip/member':

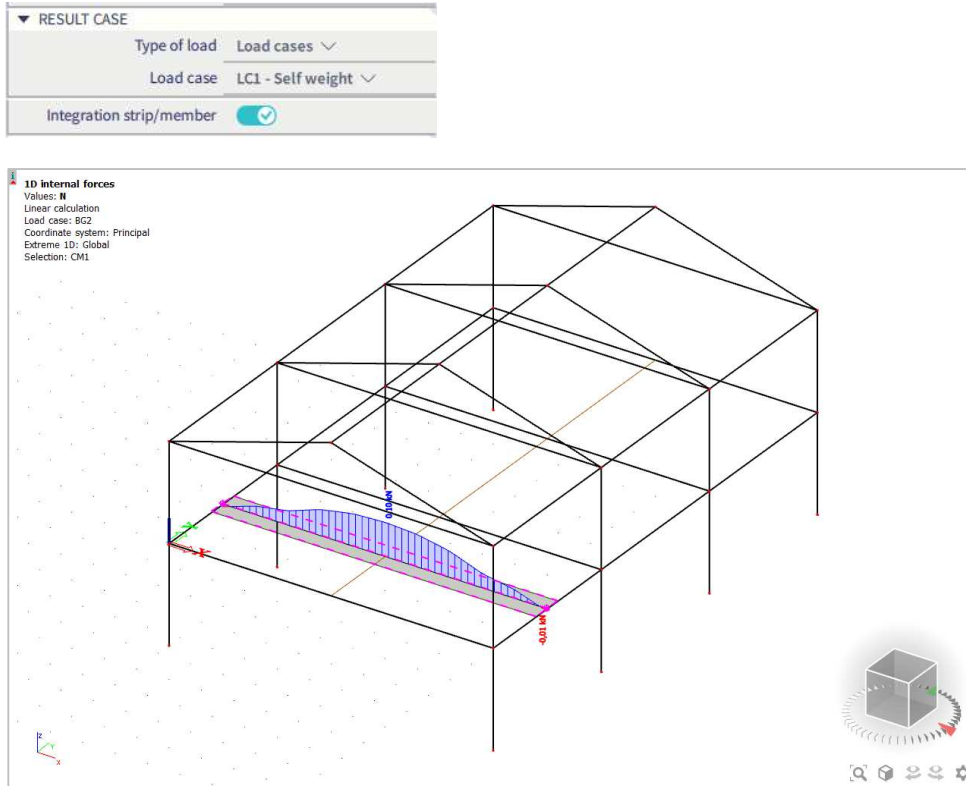

The workflow is similar for an integration member. In the integration member window, you can set the shape, dimensions and buckling data of this member.

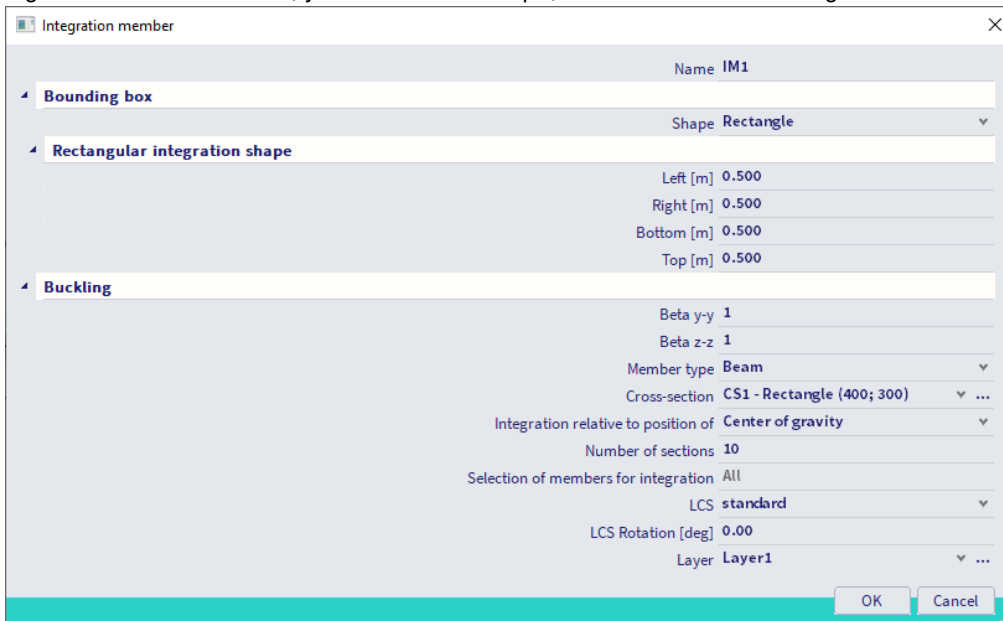



## Chapter 6: Steel design

This chapter describes the most important functions and features needed to perform a design on steel members and connections.

### 6.1. Steel setup

You can open the steel setup by going to **Main Menu** → **Design** → **Steel members** → **Settings**.

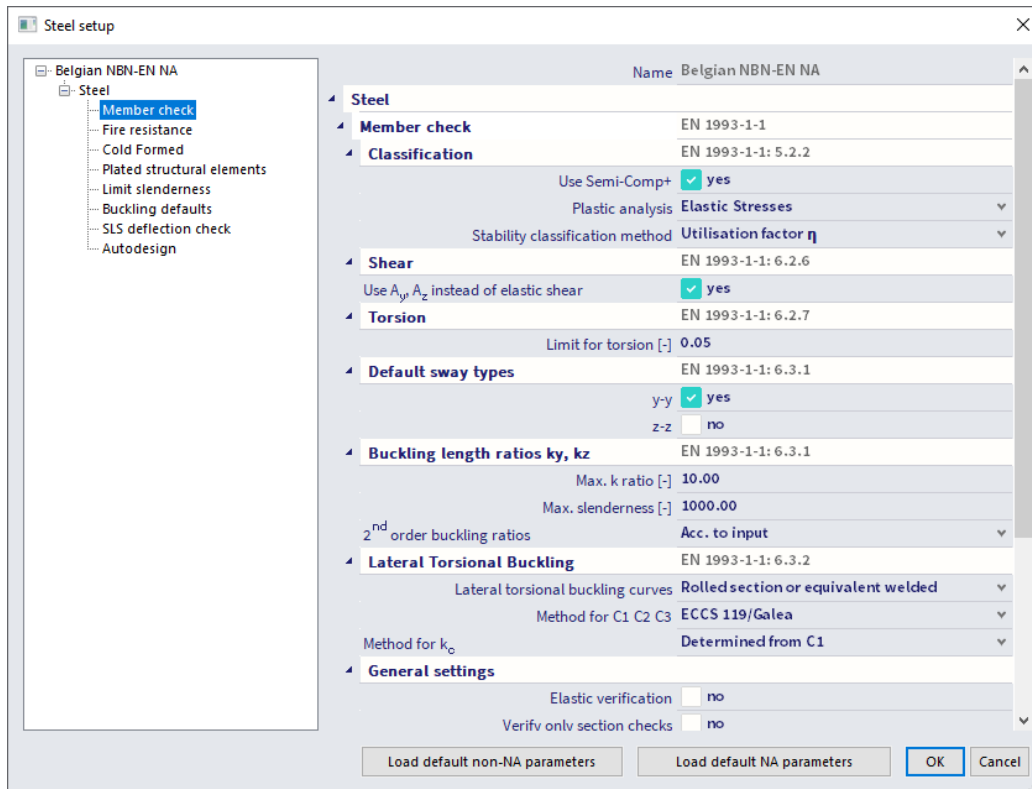

In this window you can change the general settings. These settings have an influence on the checks. By default, these settings are according to the Eurocode. You can find more detailed information about this menu in the steel manual.

You can overrule the settings in the steel setup for one (or more) member(s) by assigning '**Steel member data**'. If you choose this option, a window will open where you can assign these settings to individual member(s).

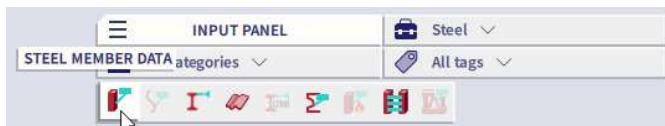

## 6.2. Buckling settings

You have several ways to determine the buckling factors. The first option is to leave everything by default and let SCIA calculate the buckling factors. A second option is to assign buckling groups to members to guide the determination of the buckling factor.

### 6.2.1. Default buckling calculation

When you use this method only one adjustment needs to be made. In the steel setup you need to set the default sway type.

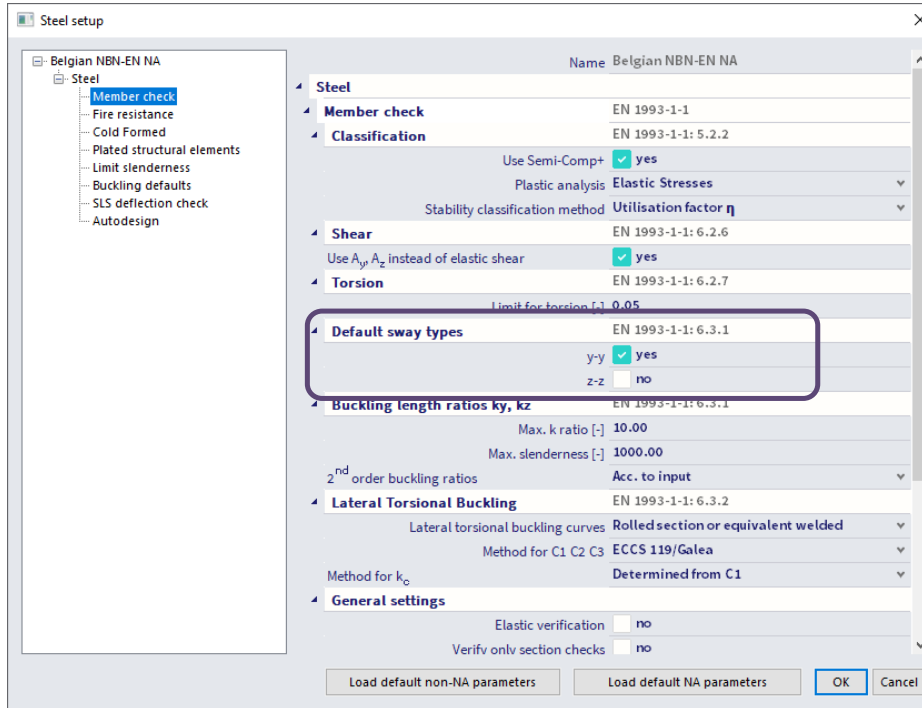

With these settings it is determined if the structure is sway or not (braced or not) around the strong (y-y) and weak (z-z) axis of the profiles in the structure. Depending on this setting a different formula is used to determine the buckling factor:

- for a non-sway structure:

$$k = \frac{(\rho_1 \rho_2 + 5\rho_1 + 5\rho_2 + 24)(\rho_1 \rho_2 + 4\rho_1 + 4\rho_2 + 12)^2}{(2\rho_1 \rho_2 + 11\rho_1 + 5\rho_2 + 24)(2\rho_1 \rho_2 + 5\rho_1 + 11\rho_2 + 24)}$$

- for a sway structure:

$$k = x \sqrt{\frac{\pi^2}{\rho_1 x} + 4}$$

with

k	the buckling factor
L	the system length
E	the modulus of Young
I	the moment of inertia
$C_i$	the stiffness in node i
$M_i$	the moment in node i
$\phi_i$	the rotation in node i

$$x = \frac{4\rho_1 \rho_2 + \pi^2 \rho_1}{\pi^2 (\rho_1 + \rho_2) + 8\rho_1 \rho_2}$$

$$\rho_i = \frac{C_i L}{EI}$$

$$C_i = \frac{M_i}{\phi_i}$$



The values for  $M_i$  and  $\phi_i$  are approximately determined by the internal forces and the deformations, calculated by load cases which generate deformation forms, having an affinity with the buckling form. So, when performing a linear calculation, then 2 additional (hidden) load cases are calculated, just to calculate the buckling factors for the elements.

This calculation is automatically done when calculating the construction linearly.

**NOTE: when calculating nonlinear, you should also perform a linear calculation otherwise no buckling factors are calculated, and no steel code check can be performed.**

The following loads and load cases are considered in the linear calculation for the calculation of the buckling factors:

- load case 1:
  - on the beams, local distributed loads  $q_y = 1 \text{ N/m}$  and  $q_z = -100 \text{ N/m}$  are used;
  - on the columns, global distributed loads  $Q_x = 10000 \text{ N/m}$  and  $Q_y = 10000 \text{ N/m}$  are used.
- load case 2:
  - on the beams, local distributed loads  $q_y = -1 \text{ N/m}$  and  $q_z = -100 \text{ N/m}$  are used;
  - on the columns, global distributed loads  $Q_x = -10000 \text{ N/m}$  and  $Q_y = -10000 \text{ N/m}$  are used.

The used approach gives good results for frame structures with **perpendicular rigid or semi-rigid beam connections**. **For other cases, you must evaluate the presented buckling ratios.**

The system length of every buckling system is automatically determined by SCIA Engineer. All elements (with the same cross-section, ...) that lie on the same line are – by default – in the same buckling system. The buckling system can be split up in multiple systems when there is a support or a member perpendicular on the member in the direction of the strong or weak axis. The buckling system is only shortened for the relevant axis.

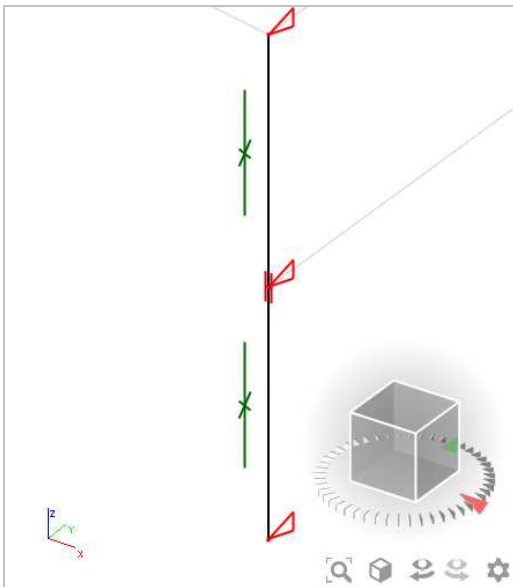

### 6.2.2. Assign buckling groups

To have more influence on the determination of the buckling factors, you can assign buckling groups to members. You can use the same buckling group for members that have the same buckling system (same length and buckling supports).

To create a buckling group for a member, select the member and press on the manage-icon next to the **'System lengths and buckling settings'** property in the property panel.

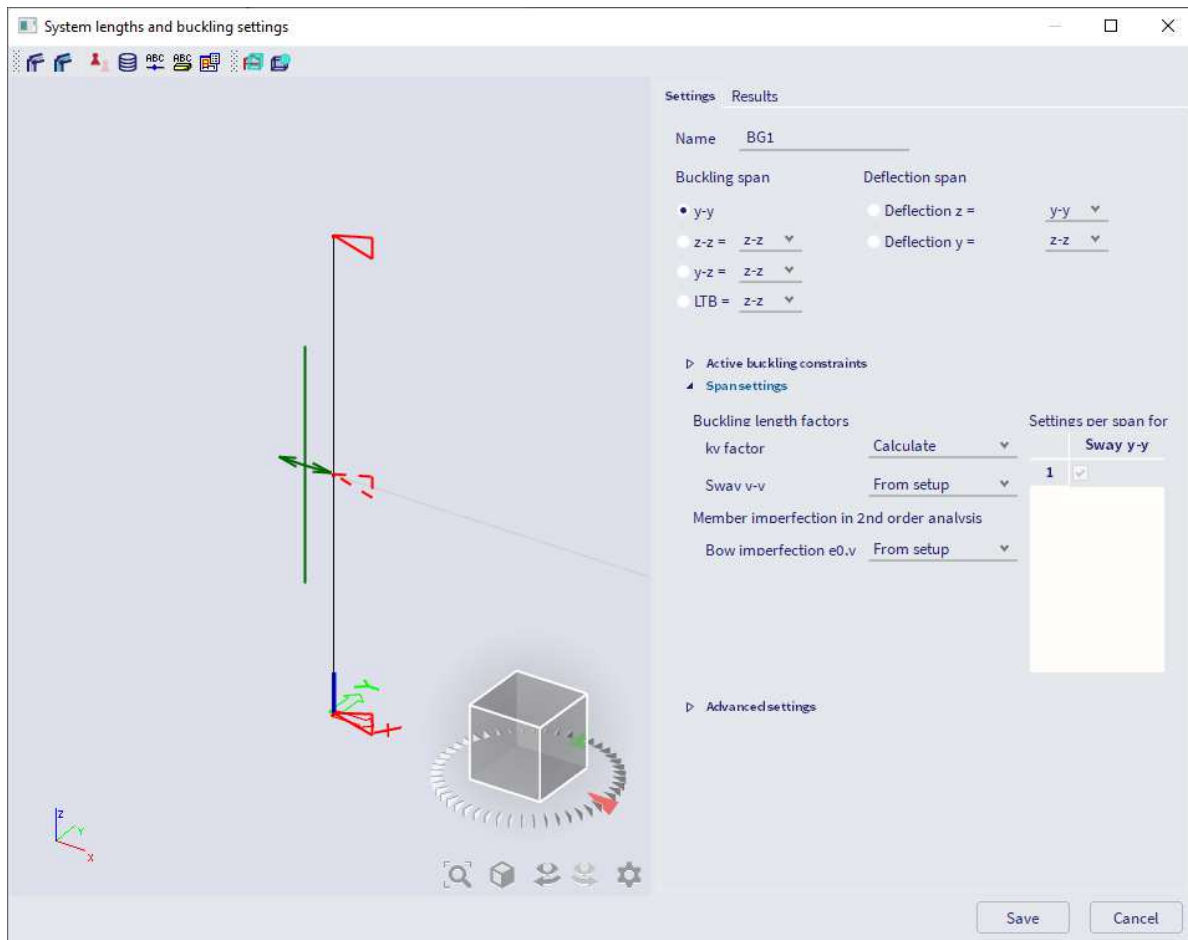
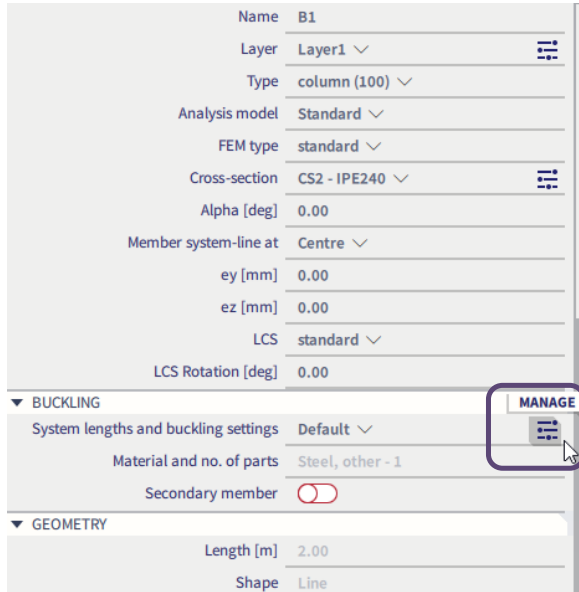

- Buckling constraints:** you can set the buckling constraints by clicking on the triangles or by opening the active buckling constraints and checking/unchecking the boxes. Adding a constraint shortens the buckling system.

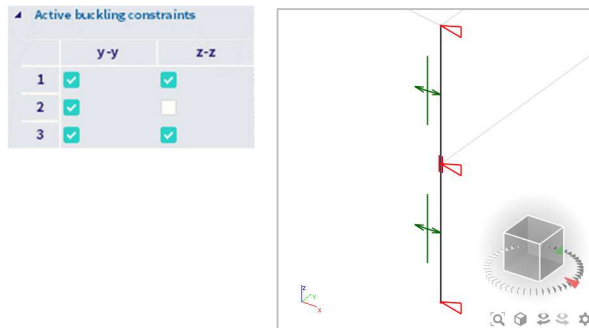

- Sway setting:** you can determine if the structure is sway or not along the active axis by clicking on the green line or by changing the 'Sway' setting. A cross means non-sway and a double arrow means sway.

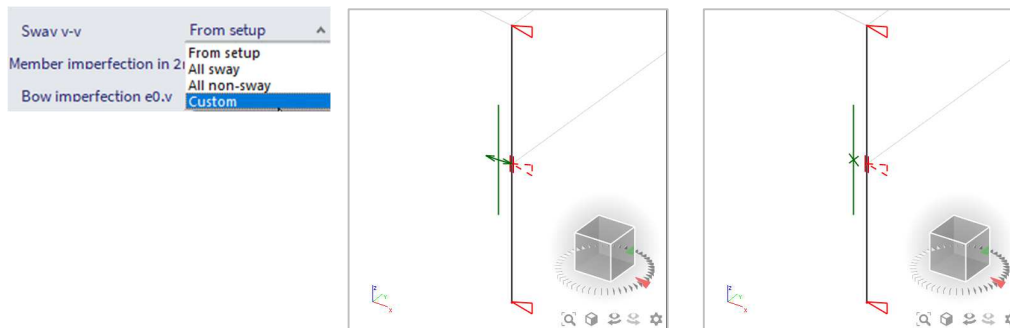

- Buckling span:** this setting determines what axis you are changing (strong or weak).

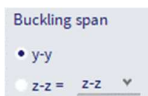

- k-factor:** the k-factor can be calculated by SCIA Engineer as explained above, can be set by you or the buckling length can be set by you. When you choose 'factor' or 'length' the value can be changed in the table next to the setting.

Buckling length factors		Settings per span for v-v axis		
kv factor	Factor	ky [-]	Sway y-y	
1	Calculate	1.00	<input checked="" type="checkbox"/>	
2	Factor	1.00	<input checked="" type="checkbox"/>	
	Length			

After setting the buckling group you need to press [Save]-button to apply it to the member. The property now changed in the property panel. You can assign it to other members with the same buckling system. The buckling group overwrites the settings for buckling (default sway) in the steel setup.

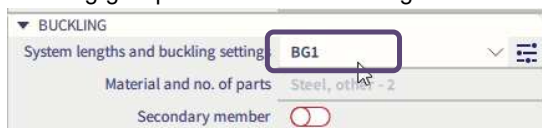

## 6.3. Steel member data

There are some effects that cannot be considered in the model that have an influence on the check. You can take this into account by adding 'Member check data'. This is data that has only an influence on the check. These elements are not 'physically' added to the model and have no influence on the internal forces.

The following member check data will be discussed in this course:  
LTB Restraints, Steel (web) stiffeners and Sheeting.

### 6.3.1. LTB restraints

Via the Input Panel:

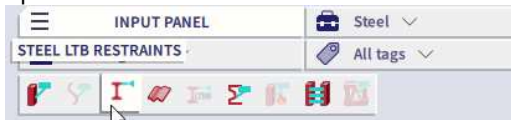

The LTB (Lateral Torsional Buckling) length can be shorter than determined by SCIA Engineer. This is because members are connected by their centre lines, or because some elements are not modelled. An LTB restraint is model data added to a beam to change the LTB length of this beam. The new LTB length is the distance between the added LTB restraints.

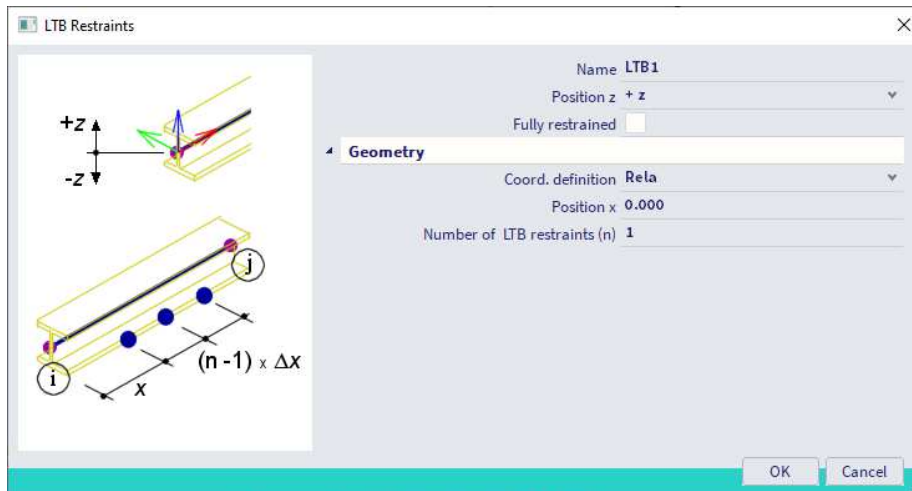

You need to set the position (top or bottom of the member) and the location of the restraints.

### 6.3.2. Steel stiffeners

Via the SCIA Spotlight:

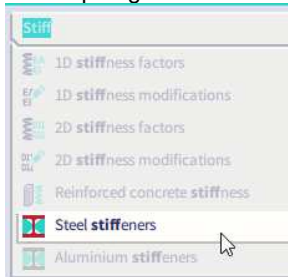

Stiffeners increase the shear area of a section. This is advantageous for the shear check. This model data is added because it is not possible to 'physically' model the stiffener. This is because a member (beam/column) is a 1D member and thus has no surface.

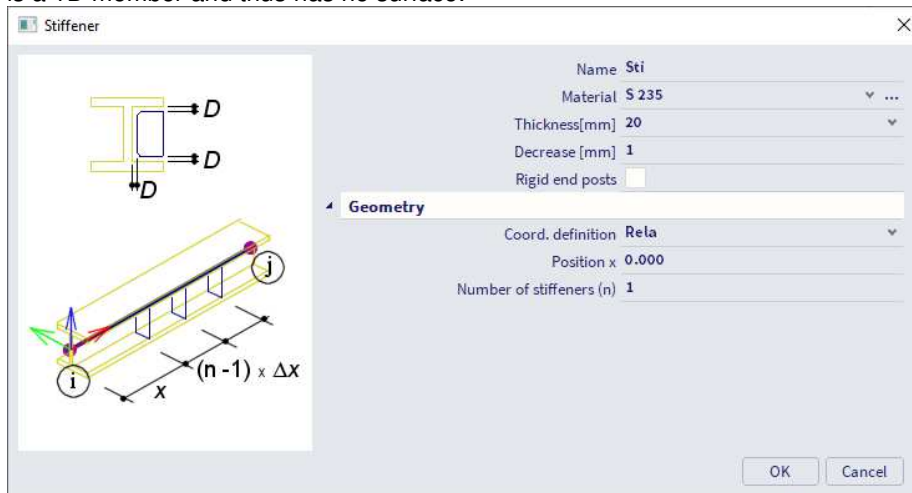

To add a stiffener, you need to set its geometry, material, and position.

### 6.3.3. Sheeting

Via the Input Panel:

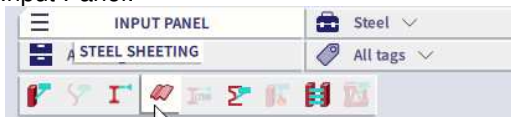

Usually, the sheeting is not modelled. This is because the assumption is made that for a steel hall the complete load is transferred to the 1D structure. To take the stiffness of the sheeting + the effect on the calculation of  $M_{cr}$  into account without changing the standard assumption, this model data can be added.

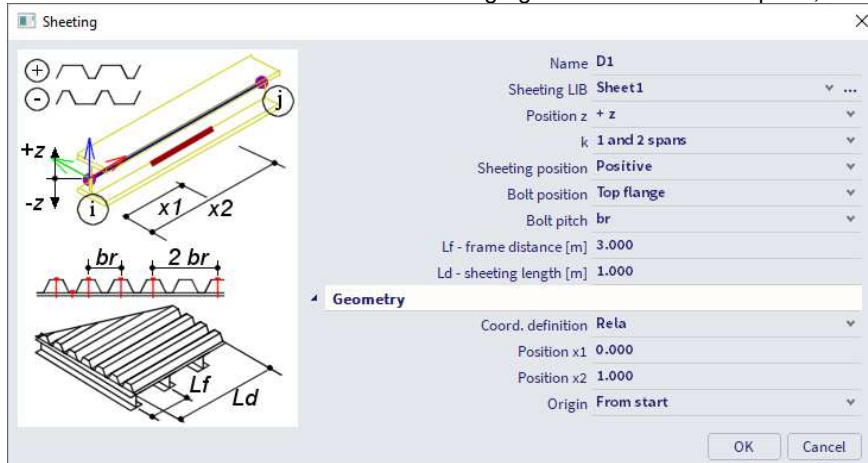

You need to set the parameters of the sheeting and its location.

**NOTE: you can find more information about the member check data in the steel manual.**

## 6.4. ULS Check

You can find the ULS check in **Main Menu → Design → Steel members** after calculating the project.

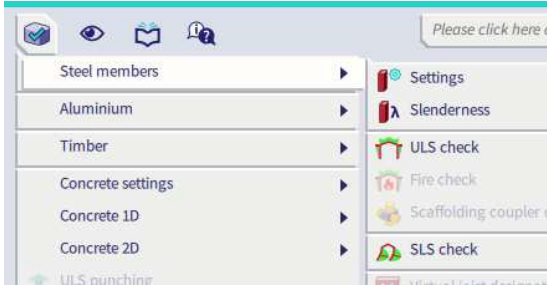

Graphically it gives you the highest unity check (from all checks performed) per section of a member. You can perform a section check and a stability check. All checks are performed according to the Eurocode. Next to the graphic output you can also open the preview to see more detailed results.

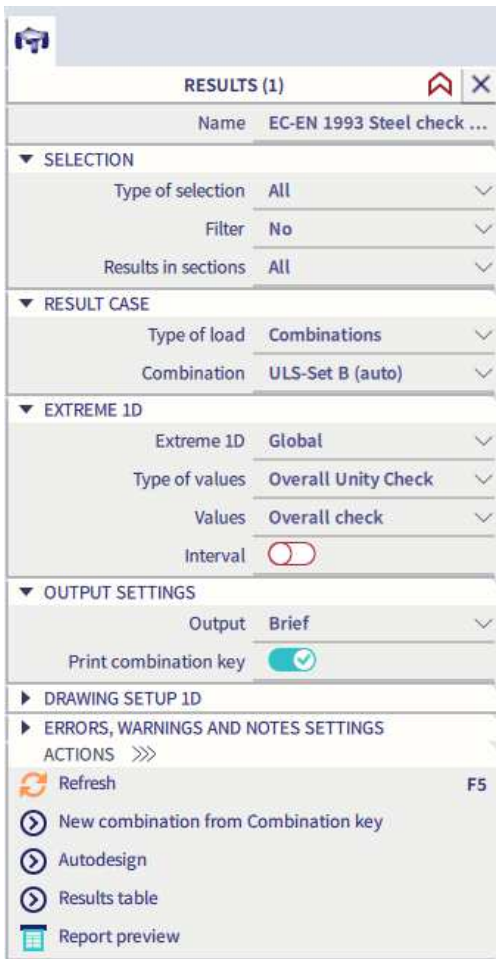

### 6.4.1. Graphic output

To view the graphic output, you need to set the property panel correctly. Most of the settings are the same as in the 'Results' menu.

- **Type of values:** you can choose between 'overall unity check', 'section check' or 'stability check'.
- **Values:** you can view the overall check (from the setting above) or a single check.

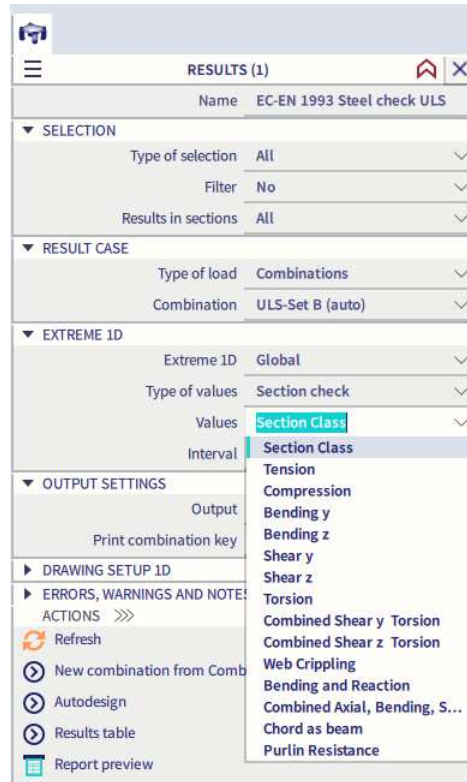

After setting the property panel, press 'Refresh' on the bottom of the property panel.

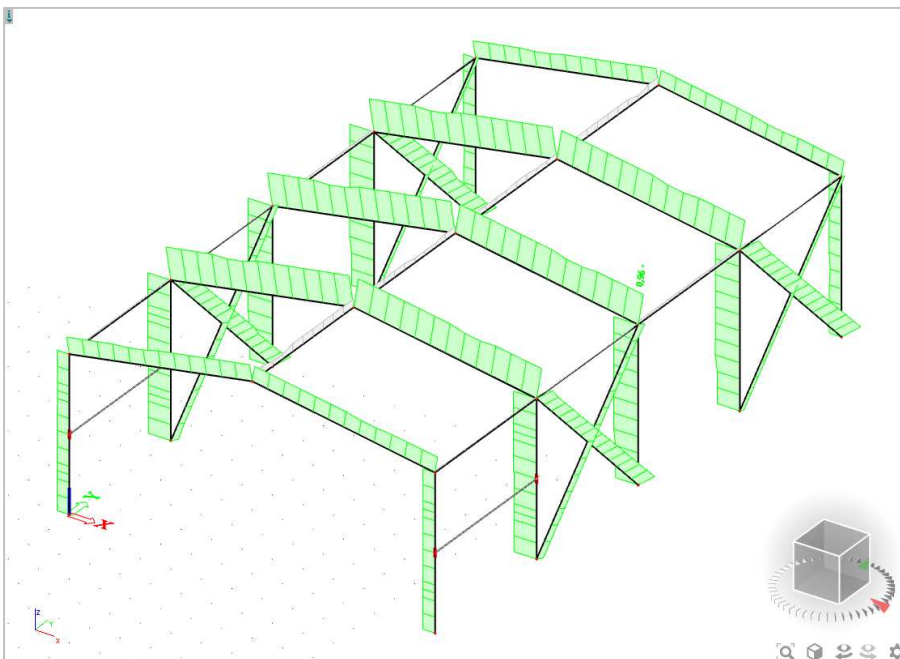

## 6.4.2. Preview

After setting the property panel and refresh you can press the preview button to see the output generated by the engineering report. This contains more detailed tables.

You have three output levels: **'Brief'**, **'Summary'** and **'Detailed'**:

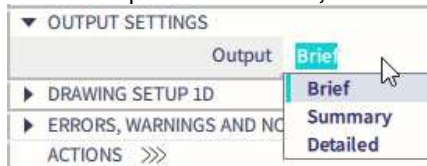

When the detailed output is selected, you can set this output to view tables with the calculated values, to view the formulas or to view both.

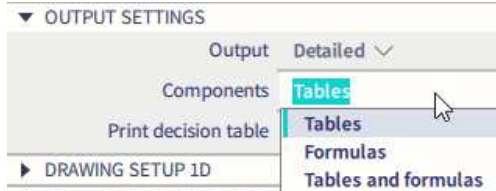

Below you can see an example of the detailed output with tables and formulas:

**Compression check**  
According to EN 1993-1-1 article 6.2.4 and formula (6.9)

A	5,3800e-03	m <sup>2</sup>
N <sub>c,Rd</sub>	1264,30	kN
Unity check	0,02	-

$$N_{c,Rd} = \frac{A \times f_y}{\gamma_{M0}} = \frac{5,3800 \cdot 10^{-3} [\text{m}^2] \times 235,0 [\text{MPa}]}{1,00} = 1264,30 [\text{kN}] \quad (\text{EC3-1-1 : 6.10})$$

$$\text{Unity check} = \frac{|N_{Ed}|}{N_{c,Rd}} = \frac{|-24,17 [\text{kN}]|}{1264,30 [\text{kN}]} = 0,02 \leq 1,00 \quad (\text{EC3-1-1 : 6.9})$$

**Bending moment check for M<sub>y</sub>**  
According to EN 1993-1-1 article 6.2.5 and formula (6.12),(6.13)

W <sub>pl,y</sub>	5,7500e-04	m <sup>3</sup>
M <sub>pl,y,Rd</sub>	135,13	kNm
Unity check	0,61	-

$$M_{pl,y,Rd} = \frac{W_{pl,y} \times f_y}{\gamma_{M0}} = \frac{5,7500 \cdot 10^{-4} [\text{m}^3] \times 235,0 [\text{MPa}]}{1,00} = 135,13 [\text{kNm}] \quad (\text{EC3-1-1 : 6.13})$$

$$\text{Unity check} = \frac{|M_{y,Ed}|}{M_{pl,y,Rd}} = \frac{|-82,71 [\text{kNm}]|}{135,13 [\text{kNm}]} = 0,61 \leq 1,00 \quad (\text{EC3-1-1 : 6.12})$$



### 6.4.3. Table output

Lastly you can view the results in the table output. When you double click on a row in the table the preview of this row is previewed. In the top you can set the output level (summary or detailed).



RESULTS TABLE

Summary ^

	Name	dx [m]	Case	Cross-section	Material	UCOverall [-]	UCSec [-]	UCStab [-]
1	B1	0,000	CO1/1	CS1 - HEA340	S 235	0,37	0,02	0,37
2	B4	0,000	CO1/1	CS1 - HEA340	S 235	0,67	0,07	0,67
3	B5	0,000	CO1/1	CS1 - HEA340	S 235	0,71	0,04	0,71
4	B8	0,000	CO1/1	CS1 - HEA340	S 235	1,22	0,13	1,22
5	B9	0,000	CO1/1	CS1 - HEA340	S 235	0,37	0,02	0,37
6	B12	0,000	CO1/1	CS1 - HEA340	S 235	0,66	0,07	0,66

EC-EN 1993 Steel check UL...

## 6.5. SLS Check

You can find the SLS check in **Main Menu → Design → Steel members** after calculating the project.



You can choose between the overall unity check or a specific value for Y or Z direction.

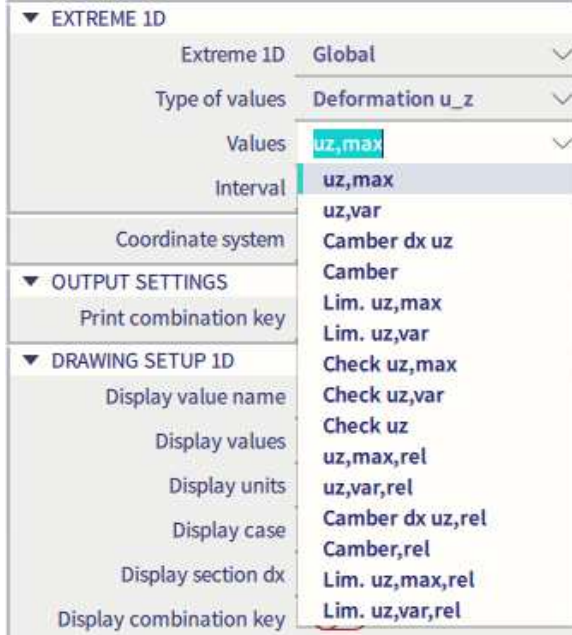

- **u,tot** or **u,var**: the relative displacement of each member for the total load or for the variable part of the load.
- **Camber**: the camber over the length of the element (dx uz) or the maximum camber over the entire element (uz,max).

**Lim. u,tot** or **Lim u,var**: the limit of the relative displacement  $L/x$  for the total load or for the variable part of the load. You can set x-value in the steel setup or on element level in the 'system lengths and buckling settings'. You can set the value for the camber there as well.

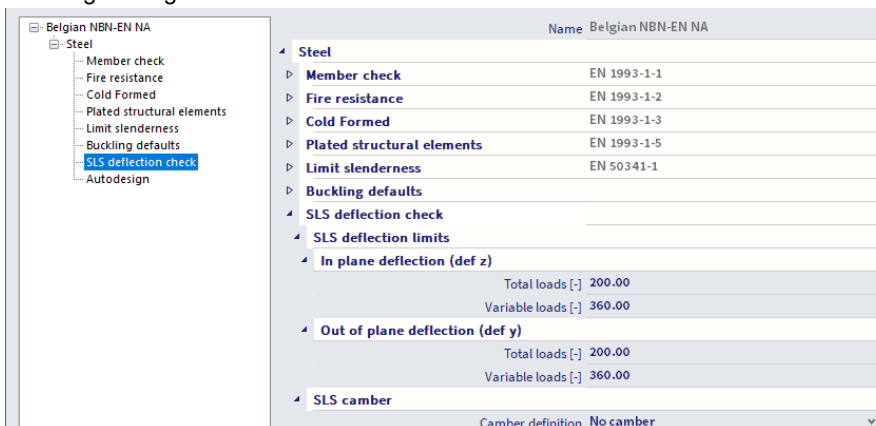

- **Check**: the relative displacement is compared with the limit. You can check the total displacement or the variable part of the displacement or you can perform an overall check.

## 6.6. General autodesign

You can access the general 'Autodesign' function via **Main Menu → Tools → Calculation & Mesh:**

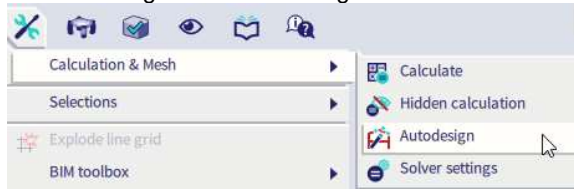

You can use the 'Autodesign' function to automatically receive an optimal unity check for the cross-sections which are used in your project. You can perform a single autodesign by following the steps below.

The first step of the autodesign you create multiple cross-section lists. By applying this cross-section list, the software is forced to only use the steel profiles that you have added to these lists, and we can avoid the use of non-standard profiles such as for example an IPE4000 or a HE260AA section.

You can find the function 'Cross-section list' in the **Main Menu → Libraries → Structure and analysis.**

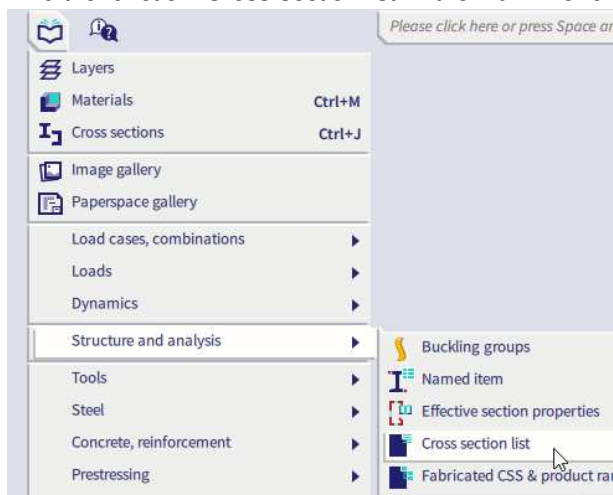

After you have selected this function, the cross-section list manager will open, and you can create a new list by selecting the button 'New'. Afterwards you can define the type of cross-section list, for example a cross-section list with only one type of steel profiles or a list with multiple types of profiles. In this example the option **'Library cross-sections of one type'** will be selected.

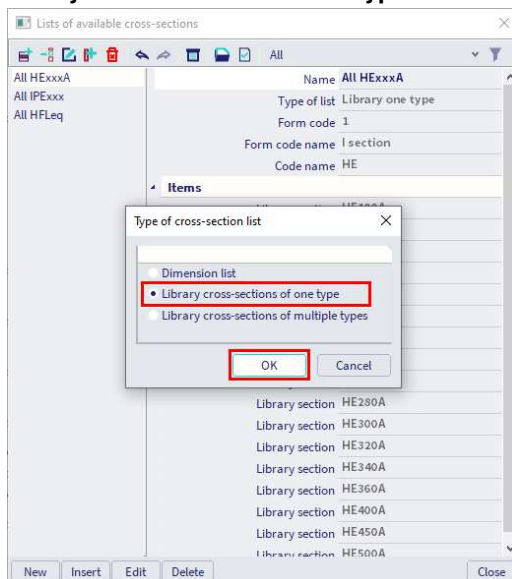

After you confirm with 'OK', the profile library will open, and you can select the cross-sections which you want to add to the list. In the following example, this will be done for HExxxA-profiles. After you have defined this cross-section list, it will be added to the cross-section list manager. You can create multiple cross-sections lists in one project.

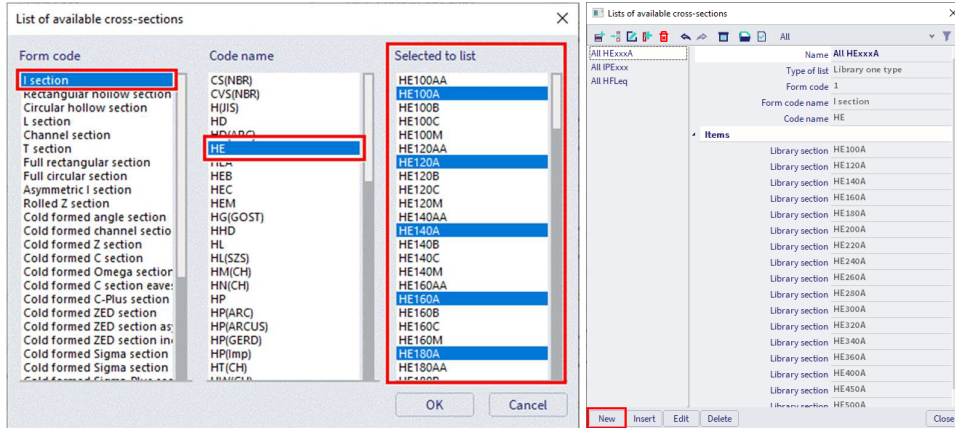

When you select the function 'Autodesign' in the **Main Menu → Tools → Calculation & Mesh**, the autodesign manager will open and you can define a new one. After you click on 'New' and on 'Add item', you can select the option '**Cross-section AutoDesign**' in the tab 'Steel'.

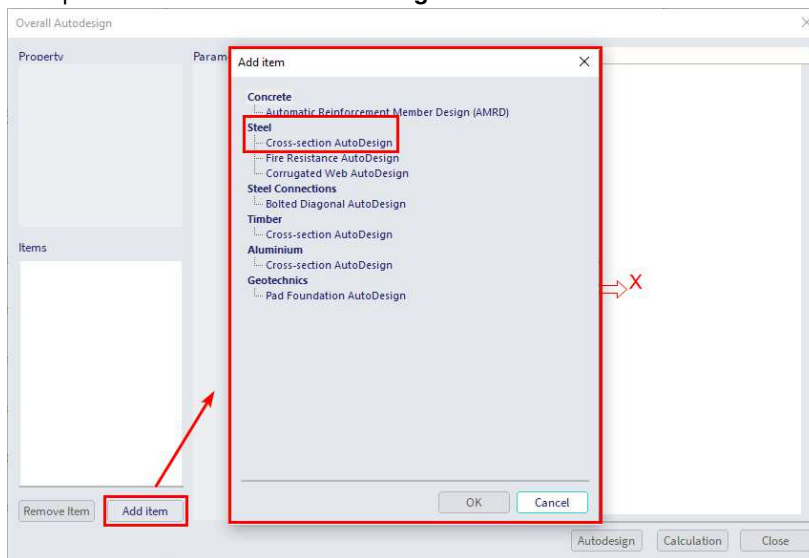

In the following step you should select and confirm the cross-section(s) which should be optimized.

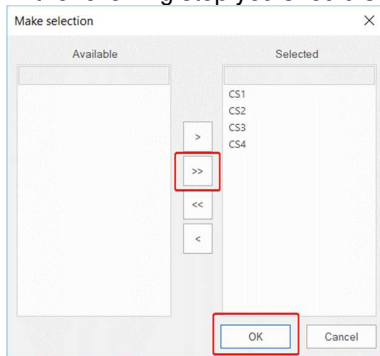

In the following window '**Overall Autodesign**', you can define the parameters for the design. It is important that you select the correct type of loads for each cross-section in the autodesign. You can perform the autodesign for a load case, for a combination or for a result class.

You can select the defined cross-section lists as well when you activate the option **'Use cross-section list'** and then select the list in the tab **'Filter list'**.

You should define the maximum value for the optimized unity check with the option **'Maximal check'**.

You can modify these parameters for each cross-section that is mentioned in the window **'Items'**.

The final step in this window is that you activate the command **'Autodesign'** at the bottom of this window.

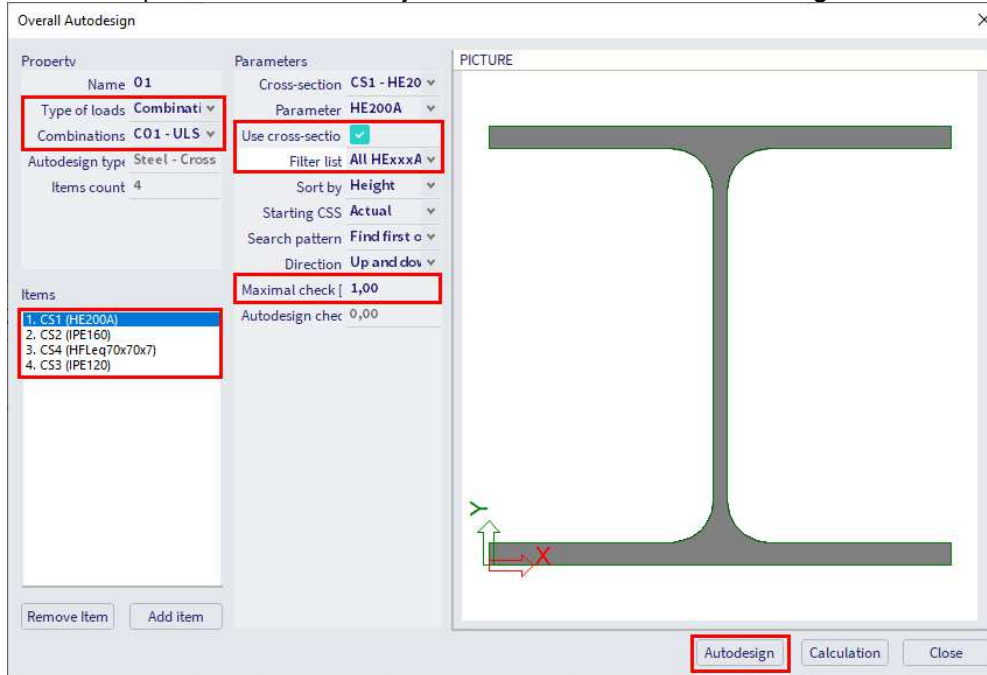

As soon as you have executed this final command, a summary of the autodesign will be displayed. This table will provide you the optimized profiles as well as the optimized unity check.

Cross-section	Parameter	Sort by	Filter list	Original cross-section	Autodesign of cross-section	Autodesign check
CS1 - HE180A	HE180A	Height	All HExxx A	CS1 - HE200A	CS1 - HE180A	0,83
CS2 - IPE220	IPE220	Height	All IPExxx	CS2 - IPE160	CS2 - IPE220	0,75
CS4 - HFL eq 90x90x9	HFL eq 90x90x9	Height		CS4 - HFL eq 70x70x7	CS4 - HFL eq 90x90x9	0,79
CS3 - IPE140	IPE140	Height	All IPExxx	CS3 - IPE120	CS3 - IPE140	0,72

Within this command, you can perform an iterative autodesign as well. You can execute this by closing the tab 'Overall Autodesign' and selecting the command 'Optim. Routine' in the autodesign manager. After you have selected this option, you can define the iterations of the design by a limit number of iterations or it can be determined automatically. In this example the number of iterations will be set to 3. The autodesign of the profiles will be executed after you have pressed on 'Start'.

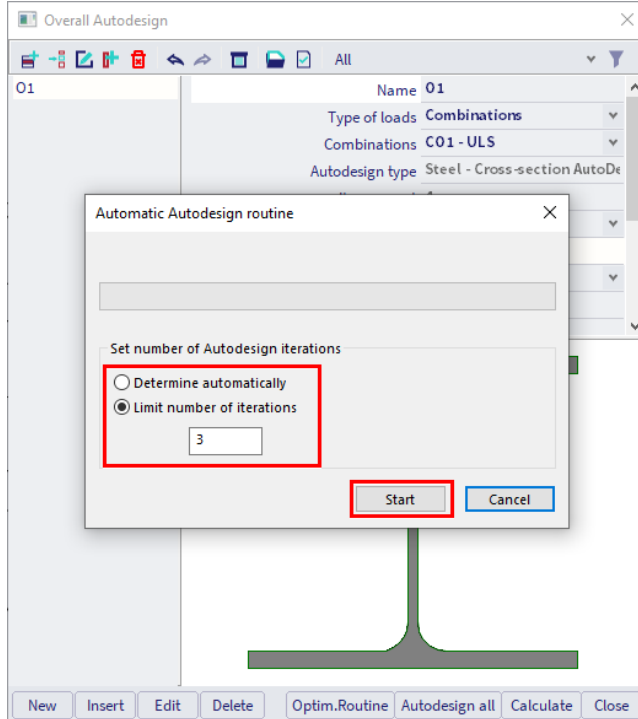

As soon as the iterations are finished, you will get an overview of all the routine steps as well as the optimized profiles and unity checks.

1. Routine step: 1					
1.1. O1					
Cross-section	Parameter	Sort by	Original cross-section	Autodesign of cross-section	Autodesign check [-]
CS1 - HE140C	HE140C	Height	CS1 - HE200A	CS1 - HE160C	0,52
CS2 - IPE2000	IPE2000	Height	CS2 - IPE160	CS2 - IPE2000	0,86
CS4 - HFLeq90x90x9	HFLeq90x90x9	Height	CS4 - HFLeq70x70x7	CS4 - HFLeq90x90x9	0,79
CS3 - IPE 140A	IPE140A	Height	CS3 - IPE120	CS3 - IPE140	0,72
2. Routine step: 2					
Cross-section	Parameter	Sort by	Original cross-section	Autodesign of cross-section	Autodesign check [-]
CS1 - HE140C	HE140C	Height	CS1 - HE160C	CS1 - HE140C	0,61
CS2 - IPE2000	IPE2000	Height	CS2 - IPE2000	CS2 - IPE200	0,99
CS4 - HFLeq90x90x9	HFLeq90x90x9	Height	CS4 - HFLeq90x90x9	CS4 - HFLeq90x90x9	0,95
CS3 - IPE 140A	IPE140A	Height	CS3 - IPE140	CS3 - IPE140A	0,99
3. Routine step: 3					
Cross-section	Parameter	Sort by	Original cross-section	Autodesign of cross-section	Autodesign check [-]
CS1 - HE140C	HE140C	Height	CS1 - HE140C	CS1 - HE140C	0,54
CS2 - IPE2000	IPE2000	Height	CS2 - IPE200	CS2 - IPE2000	0,85
CS4 - HFLeq90x90x9	HFLeq90x90x9	Height	CS4 - HFLeq90x90x9	CS4 - HFLeq90x90x9	0,98
CS3 - IPE 140A	IPE140A	Height	CS3 - IPE140A	CS3 - IPE140A	0,97



## 6.7. Connection check

To create a connection in the 'Steel' menu you should activate the functionality 'Steel connections':

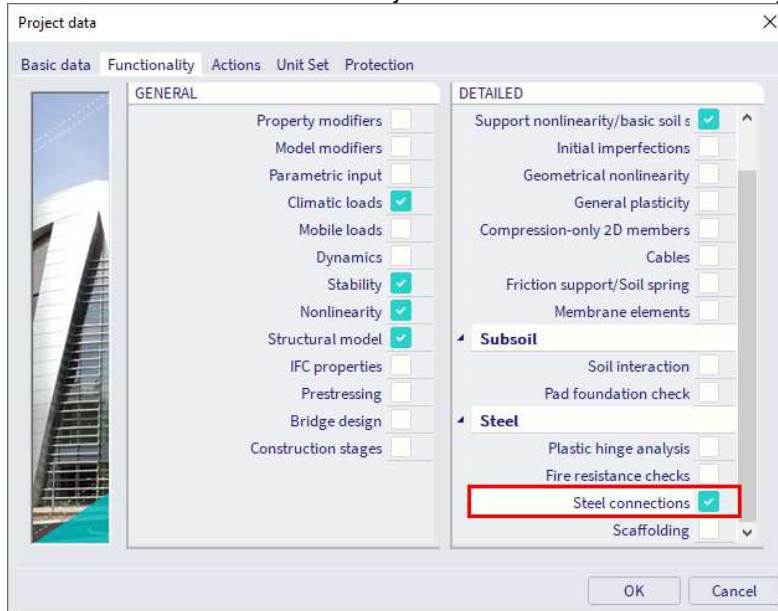

To add a connection to your model, use the Input Panel:



After you have selected a connection type, you should choose the node where you want to add the connection. In this example a strong-axis connection is chosen. After you have chosen the node, the following label will appear on the node:

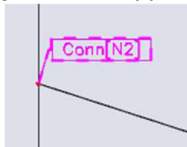

**NOTE: you can create the connection only if the members have the correct type. A column should have the type 'column' and a beam the type 'beam' (see chapter 1D elements).**

When you select the label, you can define the connection in the property panel:

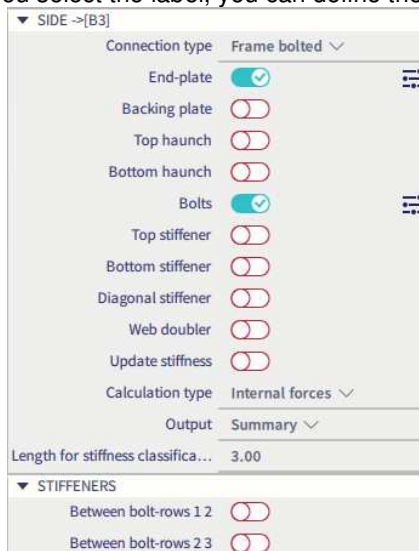

To create the connection, choose the connection type and check the components of the connection. To edit the components, press on the manage-icon next to the component.

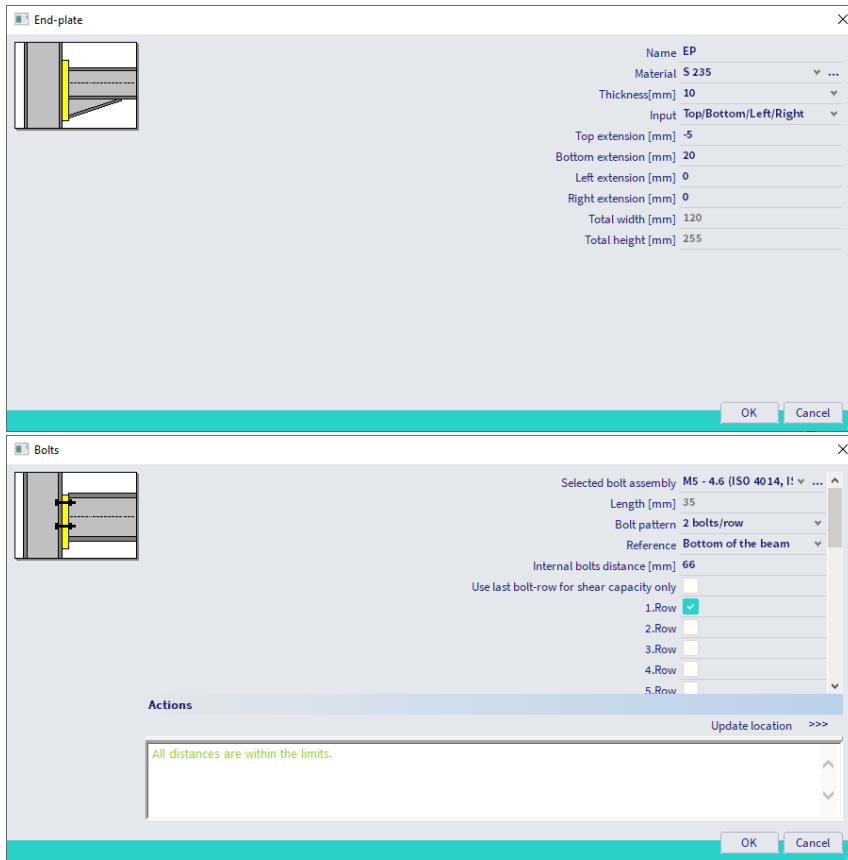

When you have defined the connection click on the 'Refresh' button at the bottom of the property panel. The preview window will automatically open. In the preview window all the strength checks according to the Eurocode will be performed.

....RESULTS:....

Unity checks

$M_{y,Ed}/M_{j,y,Rd}$	3.18
$M_{z,Ed}/M_{j,z,Rd}$	0.05
$N_{Ed}/N_{j,Rd}$	0.04
$V_{z,Ed}/V_{z,Rd}$	1.39
$V_{y,Ed}/V_{y,Rd}$	0.00
$V_{z,Ed}/V_{z,Rd} + V_{y,Ed}/V_{y,Rd}$	1.39
$M_{y,Ed}/M_{j,y,Rd} + M_{z,Ed}/M_{j,z,Rd}$	<b>3.23</b>

You can get a more detailed view by changing the output type in the property panel.

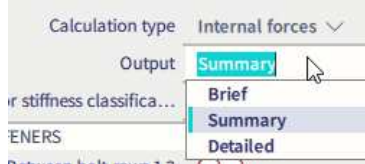



Next to the strength check, a stiffness check is performed as well. In the main model a stiffness is assumed for each node. This stiffness is fully fixed or the stiffness of a hinge that is added to the node. The stiffness assumed in the project should be checked with the connection that you just have created. If the stiffness of the connection does not lay between certain boundaries (so that it can be assumed to be the same as the stiffness in the model), then the stiffness in the model should be adapted. In this example the stiffness of the connection (in blue) does not lay between the boundaries (a stiff node is assumed).

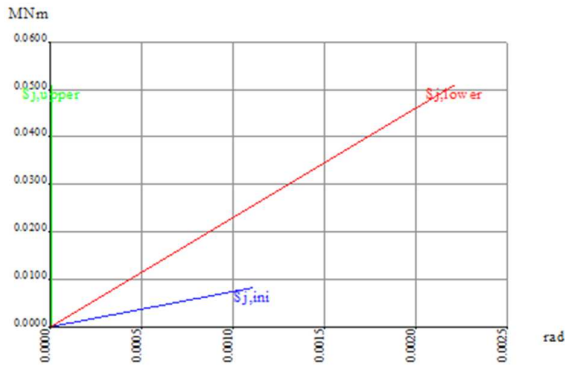

You can do this automatically by checking the option 'Update stiffness'. When you have checked this option, a hinge will be added to the node after calculating the project another time. This hinge has the real stiffness of the connection.

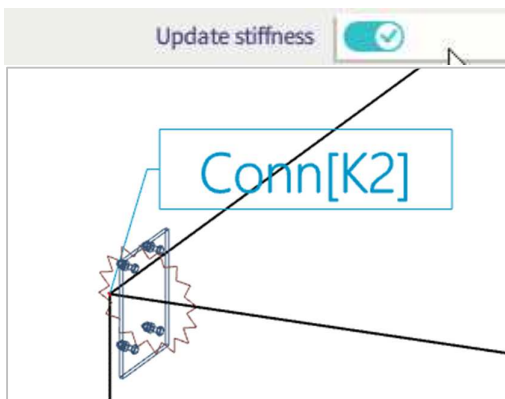

**NOTE: when the stiffness is updated the internal forces are different as well. This means that the ULS and SLS checks of the beams are different as well.**



## Chapter 7: Concrete design

### 7.1. Concrete setup

You can open the concrete setup by going to **Design → Concrete settings → Settings**.

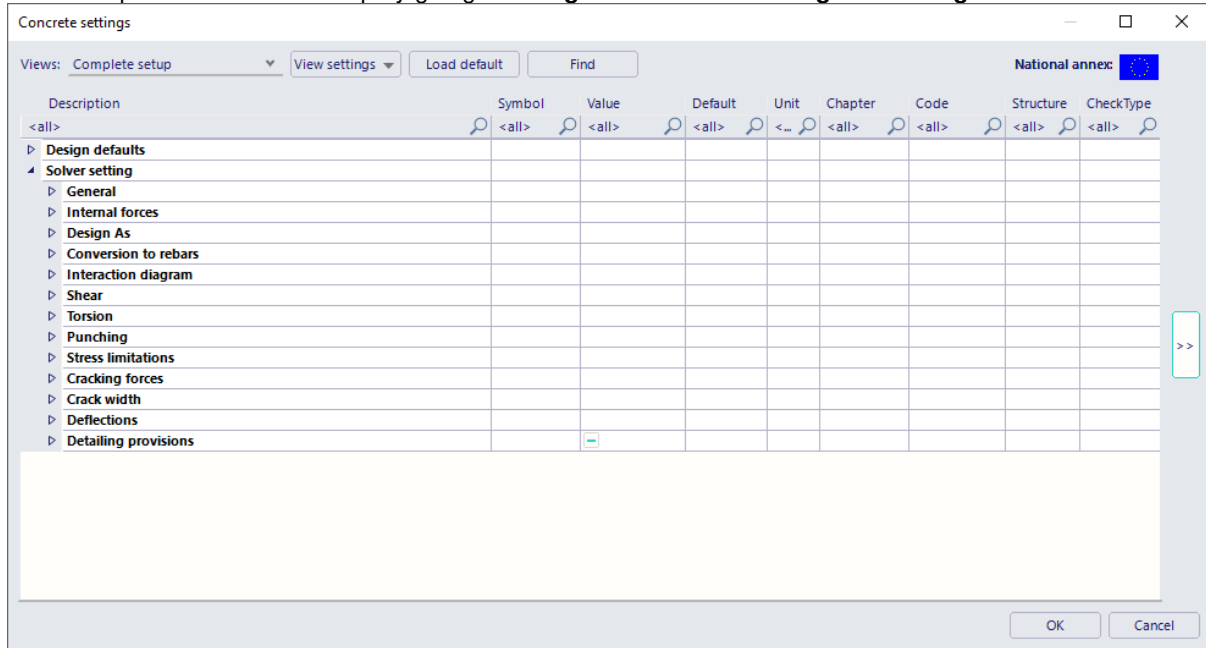

In this window you can set all concrete settings. This contains the design defaults (reinforcement, concrete cover), settings for the recalculation of internal forces and code-based settings. You can find a complete explanation of all these settings in the concrete manual.

The settings done in the concrete setup are done for the whole project. You can change these settings also for only one member by using the option 'Setting per member'. This option will open a window where you can change the settings and assign them to a selection of members.

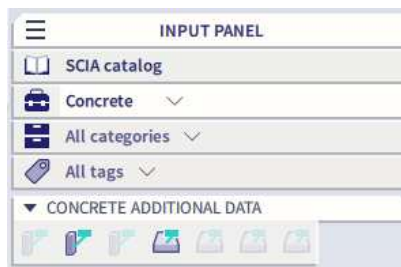

### 7.2. Recalculated internal forces

For the concrete design recalculated internal forces are used. Following modifications can be applied. You can find this table in the concrete settings menu.

Solver setting						
Internal forces						
Shear force reduction above supports					6.2.1(8)	EN 1992-1-1
Moment reduction above supports					5.3.2.2 (4)	EN 1992-1-1
Shifting of moment curve to cover additional tensile force cause...		<input checked="" type="checkbox"/>	<input checked="" type="checkbox"/>		9.2.1.3(2)	EN 1992-1-1
Geometric imperfection in ULS	$e_i, ULS$	<input checked="" type="checkbox"/>	<input checked="" type="checkbox"/>		5.2(2)	EN 1992-1-1
Geometric imperfection in SLS	$e_i, SLS$	<input type="checkbox"/>	<input type="checkbox"/>		5.2(3)	EN 1992-1-1
Minimum eccentricity	$e_{min}$	<input checked="" type="checkbox"/>	In first order ec...	In first ord...	6.1(4)	EN 1992-1-1
First order eccentricity with the equivalent moment		<input checked="" type="checkbox"/>	<input checked="" type="checkbox"/>		5.8.8.2(2)	EN 1992-1-1
Second order eccentricity	$e_2$	<input checked="" type="checkbox"/>	<input checked="" type="checkbox"/>		5.8.8	EN 1992-1-1
Internal forces modifications						

**Shear force/Moment reduction above supports**

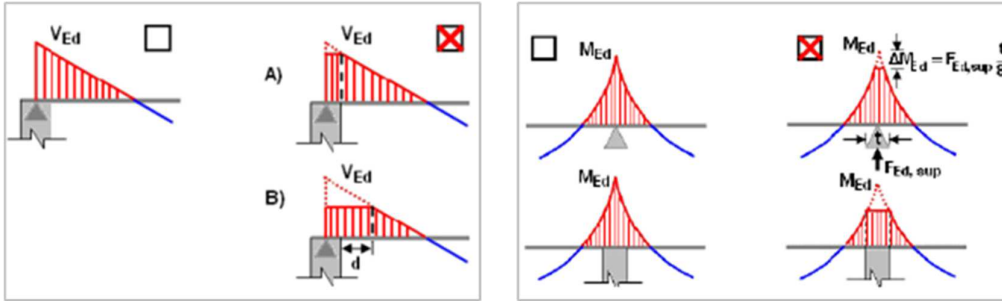

You can view the values for the recalculated internal forces with **Design** → **Concrete 1D** → **Internal forces for design**. You can view the normal internal forces (N, M, V) as well as the recalculated internal forces (Ned, Med, Ved).

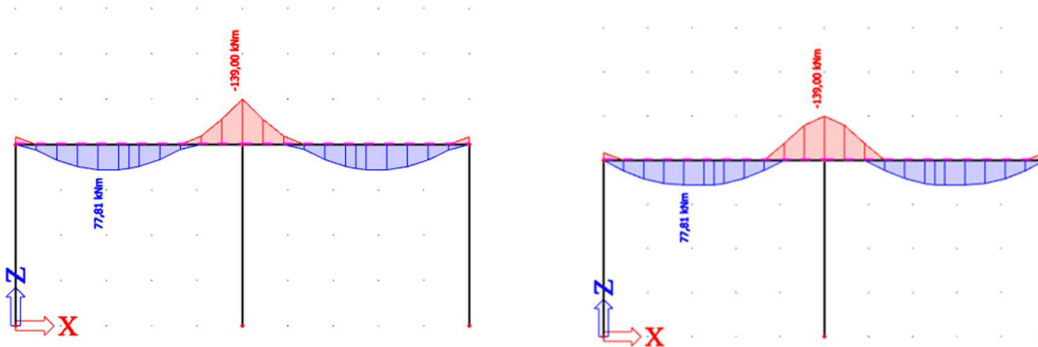

**Shift rule**

This option takes an extra tensile force caused by shear by shifting the moment line into account:

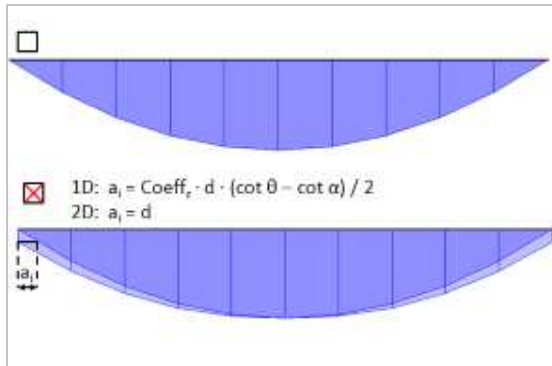

**Geometric imperfection**

This option adds a geometric imperfection:

- $\theta_1 = 0$
- $\theta_1 = \theta_0 \cdot \alpha_h \cdot \alpha_m$

**Minimum value of eccentricity**

This option takes a minimum value for eccentricity into account:

- A) No  $e_0 = e_1 + e_i$   
 $e = e_0 + e_2$
- B) Min. ecc. to first order ecc.  
 $e_0 = \max(e_1 + e_i; e_{0\min})$   
 $e = e_0 + e_2$
- C) Min. ecc. to final ecc.  
 $e_0 = e_1 + e_i$   
 $e = \max(e_0 + e_2; e_{0\min})$
- $e_{0\min} = \max(h/30; 20\text{mm})$

**First order eccentricity with equivalent moment**

This option calculates an equivalent first order moment for the whole member instead of having different values:

$$M_{0e} = 0,6 \cdot M_{02} + 0,4 \cdot M_{01} \geq 0,4 \cdot M_{02}$$

**Second order eccentricity**

This setting takes the second order effect into account:

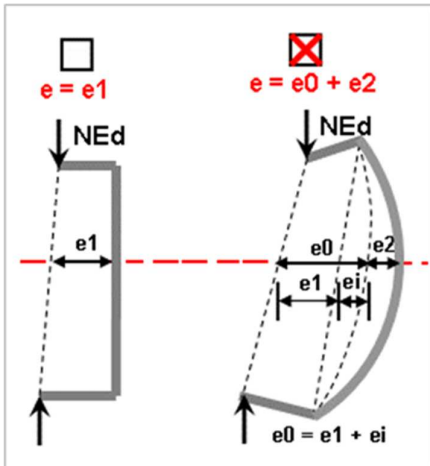

### 7.3. Provided reinforcement

Before you calculate the theoretical reinforcement, you can add a template of reinforcement to your element(s). You can use this template to:

- compare the template with the calculated theoretical reinforcement. By doing this, you can easily see where this basic template is not sufficient;
- convert to user reinforcement (**only for 1D members**), perform the punching design and crack width check (**only for 2D members**) and calculate the code dependent deflections.

The reinforcement added by the template is called ‘**Provided reinforcement**’.

To add ‘Provided reinforcement’, go to **Design → concrete settings → Settings**. This example is for a 2D member. The workflow is the same for 1D members.

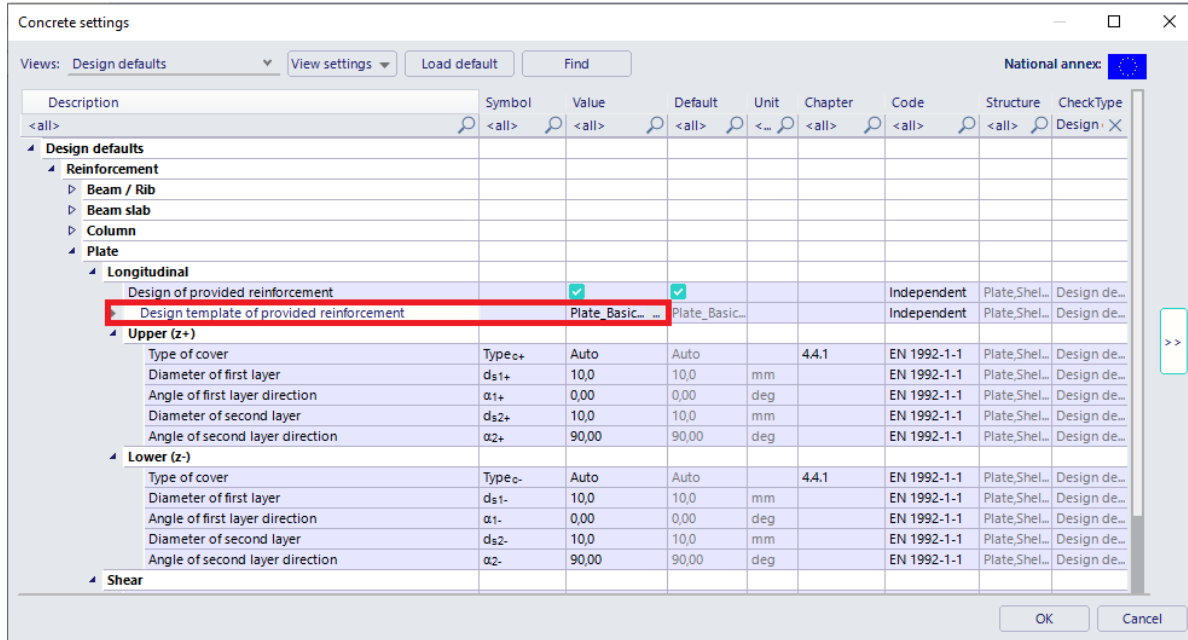

Click on the 3 dots next to the ‘Design template of provided reinforcement’. This opens a window with all the default templates.

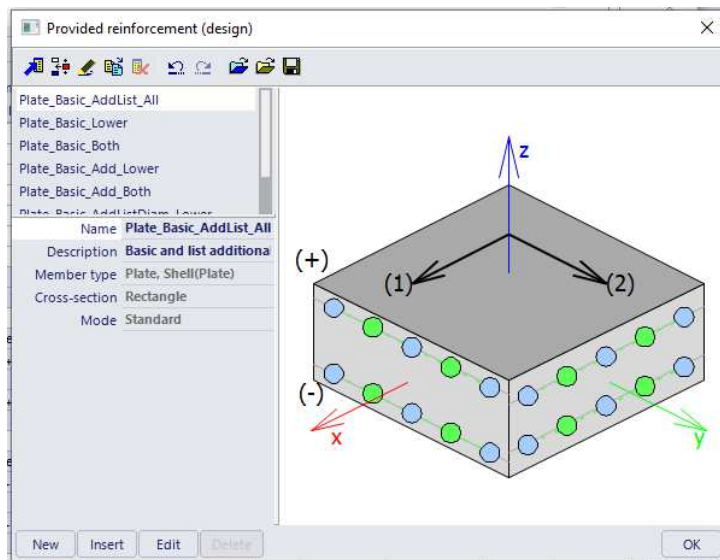

You can select one of these templates, make a new one or edit one of the existing templates. Select the first template and click on 'Edit'.

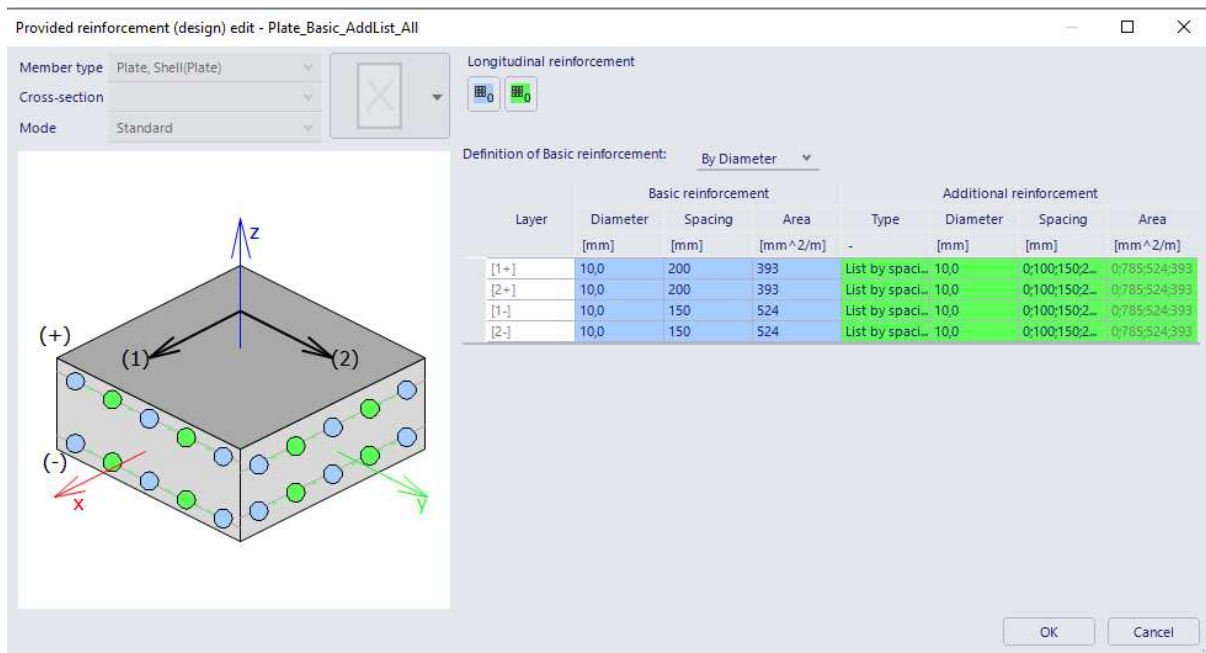

In this window you can define the reinforcement. There are 2 types of reinforcement in templates:

- **Basic reinforcement:** this type of reinforcement is added over the entire plate.
- **Additional reinforcement:** this type of reinforcement is only added in zones where, according to the calculated theoretical reinforcement, extra reinforcement is needed. You can define a single diameter and spacing as extra reinforcement or a list of reinforcement with either various diameters or various spacings.

## 7.4. Required reinforcement

You can find the required reinforcement under **Design** → **Concrete 1D/2D** → **1D reinforcement design/ULS & SLS reinforcement**.

### 7.4.1. 1D members

In the menu '1D reinforcement design' you have 2 types of values:

- **Required:** these values represent the theoretical reinforcement calculated by SCIA Engineer. The following required values are available: **As,req** (amount of longitudinal reinforcement), **Aswm,req** (amount of shear reinforcement) and **Aswm,req(φ)** (same as Aswmreq but the value is displayed in diameters).

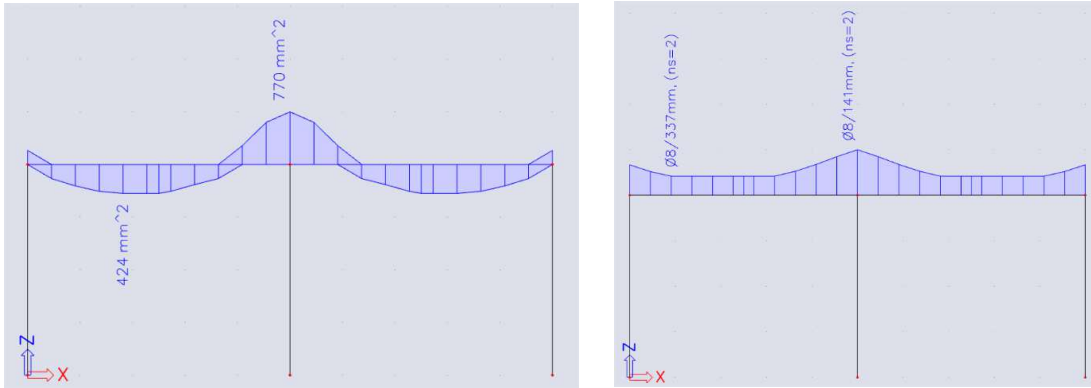

- **Provided:** the provided reinforcement can be viewed in two different values as well: **As,add,req** and **As,prov**.

**As,prov** is the provided reinforcement defined in the template.

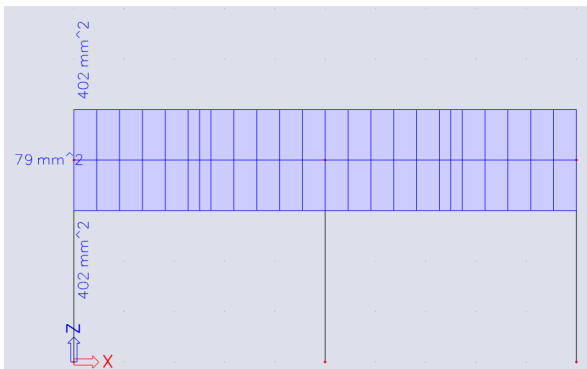

**As,add,req** is the reinforcement that is needed on top of the provided template according to the theoretical design. This means if the required value is higher than the provided value it can be seen in this view.

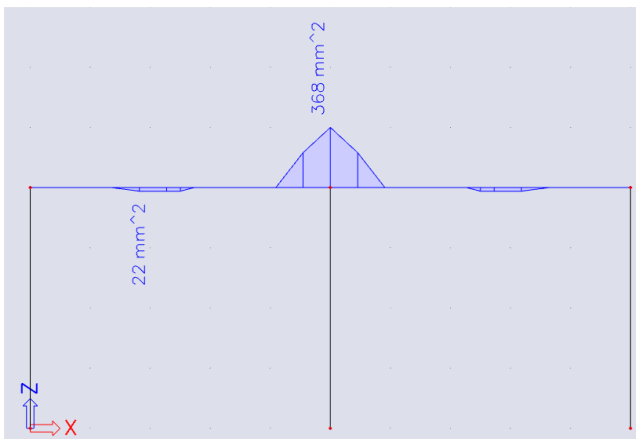



## 7.4.2. 2D members

In the menu 'ULS & SLS reinforcement' you have 4 types of values:

- **Required:** these values represent the theoretical reinforcement calculated by SCIA Engineer. This takes into account the detailing provisions.

9. Detailing of members and particular rules						
9.2 Beams						
9.3 Solidslabs						
9.3.1 Flexural reinforcement						
Check max. bar distance			✓	✓	9.3.1.1(3)	EN 1992-1-1
Check min. reinforcement area			✓	✓	9.3.1.1(1)	EN 1992-1-1
Check max. reinforcement area			✓	✓	9.3.1.1(1)	EN 1992-1-1
Check min. ratio of principal reinforcement			✓	✓	9.3.1.1(1)	EN 1992-1-1
Check max. ratio of principal reinforcement			✓	✓	9.3.1.1(1)	EN 1992-1-1
Check min. transverse ratio of secondary reinforcem...			☐	☐	9.3.1.1(2)	EN 1992-1-1
Check max.spacing of principal longitudinal reinforc...			✓	✓	9.3.1.1(3)	EN 1992-1-1
Check max.spacing of secondary longitudinal reinfor...			✓	✓	9.3.1.1(3)	EN 1992-1-1
9.3.2 Shear reinforcement						
Check min. ratio of shear reinforcement			✓	✓	9.3.2(2)	EN 1992-1-1
Check min. thickness of member with shear reinforc...			✓	✓	9.3.2(1)	EN 1992-1-1
Min. thickness of member with shear reinforcement	$h_{min}$	200	200	mm	9.3.2(1)	EN 1992-1-1
Check max. spacing of shear links			✓	✓	9.3.2(4)	EN 1992-1-1
Max. spacing of shear links	Coeff <sub>smax.p.s</sub>	0,8	0,8		9.3.2(4)	EN 1992-1-1

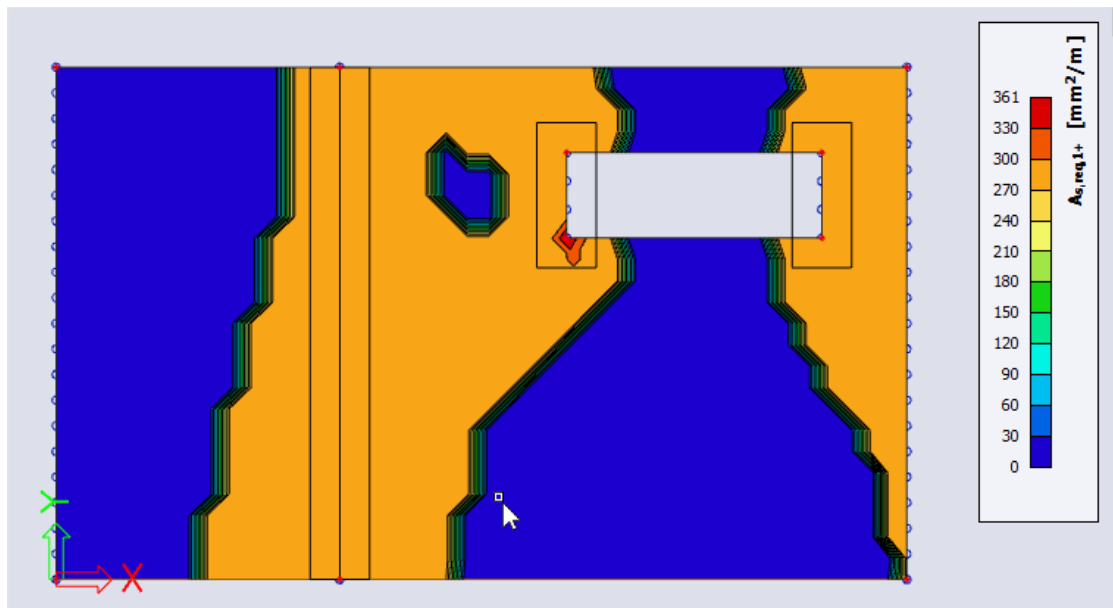

**As,req1+**: theoretical required reinforcement on the top side of the plate (positive Z direction) in the first reinforcement direction. Taking into account the detailing provisions.

- **Required (statically):** these values represent the theoretical reinforcement calculated by SCIA Engineer **without** the detailing provisions taken into account.

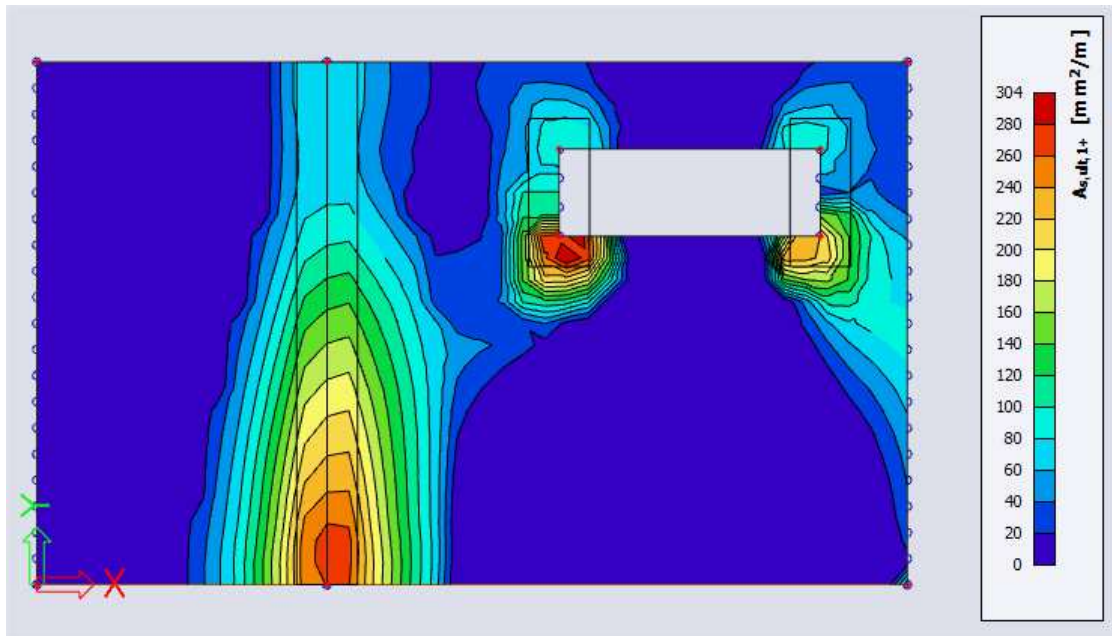

**As,stat1+:** theoretical required reinforcement on the top side of the plate (positive Z direction) in the first reinforcement direction. **Without** taking into account the detailing provisions.

- **Required (additional):** these values show if there is extra reinforcement needed on top of the provided reinforcement. Areas where this value is 0 are areas where no extra reinforcement is needed (compared to the provided reinforcement). Areas where these values are not 0 are areas where the provided reinforcement is not sufficient.

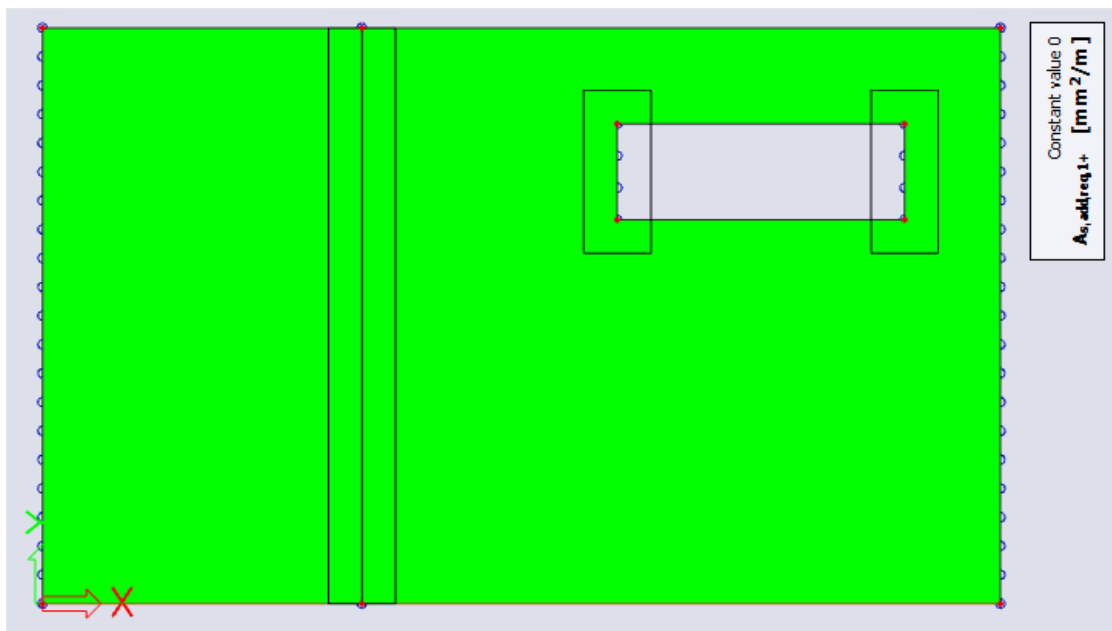

**As,add,req1+:** theoretical additional required reinforcement on top of the provided reinforcement on the top side of the plate (positive Z direction) in the first reinforcement direction.

- **Provided & User:** these values show you the provided reinforcement which you have defined in the templates, eventually together with the user reinforcement.

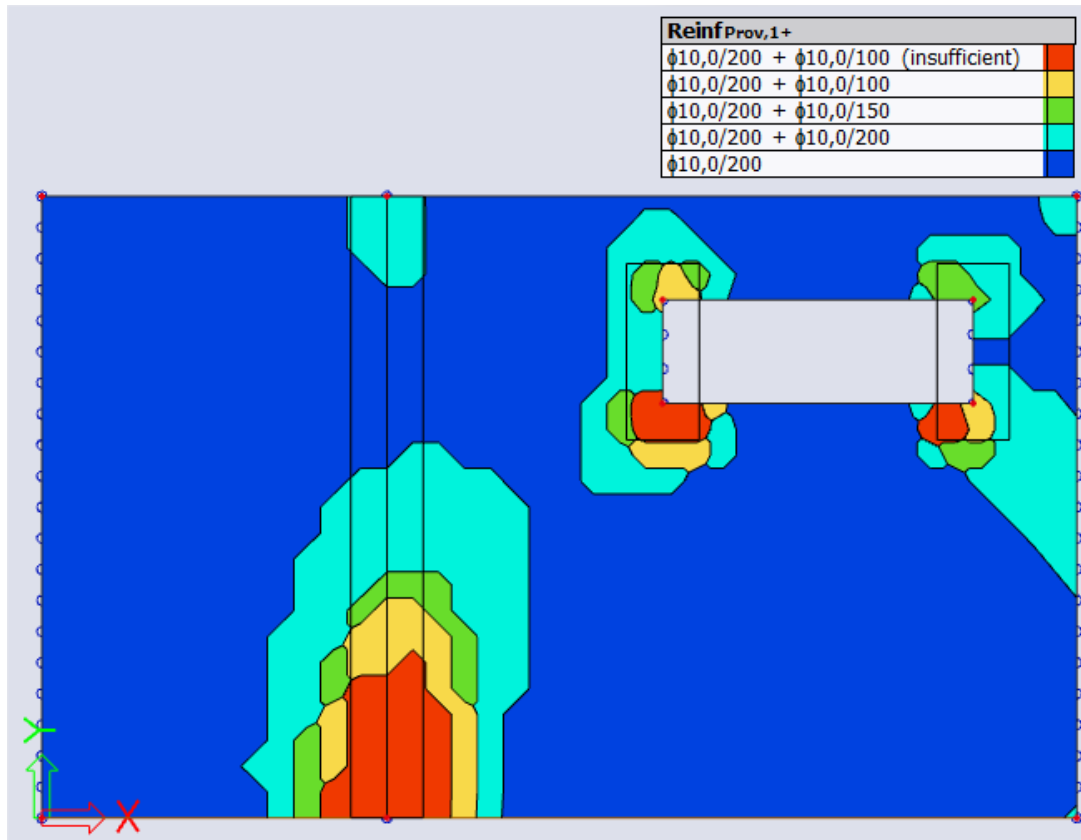

**As,Prov1+:** provided reinforcement on the plate. If elements are red the reinforcement defined in the template (and user reinforcement) is not sufficient.

## 7.5. User reinforcement

### 7.5.1. 1D members

In the theoretical reinforcement design, we have calculated where reinforcement is needed. It is possible to convert the provided reinforcement directly to practical reinforcement. You can choose for the action 'Conversion for real bars' when you have chosen the option **Design → Concrete 1D → 1D reinforcement design** and if you have generated the results for 'Provided' as 'Type of values' in the property window. Now a window appears that mentions you if it was possible to convert into real bars or not. If not, some explanation is given.

Afterwards you can edit the reinforcement by selecting the reinforcement data and choosing the action 'Edit reinforcement'.

You can also input manually the practical reinforcement by adding '1D reinforcement' for the whole length of the beam.

You can first select a template for the longitudinal reinforcement:

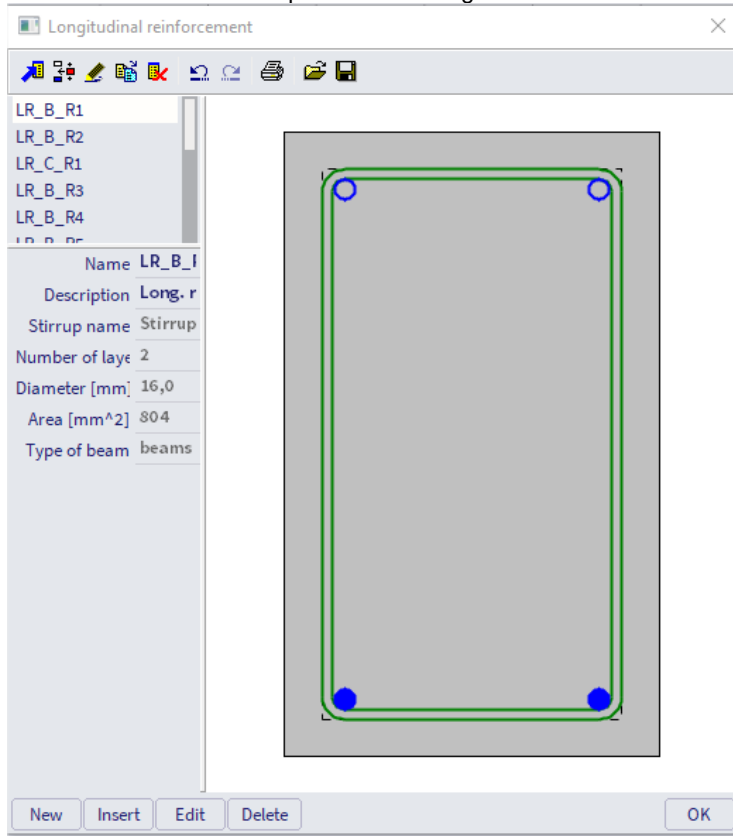

Next, you have to decide where the parameters of reinforcement are coming from:

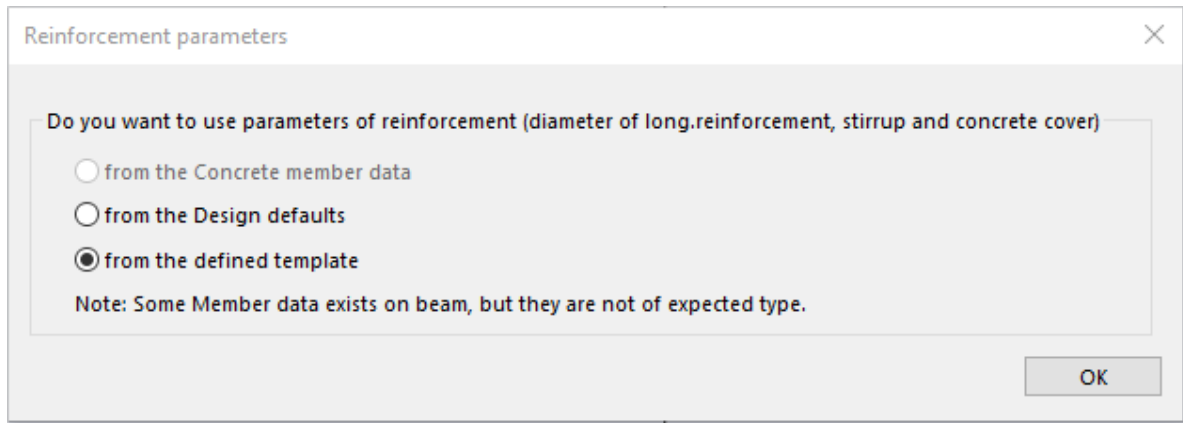

Now the practical reinforcement is shown graphically on the screen:

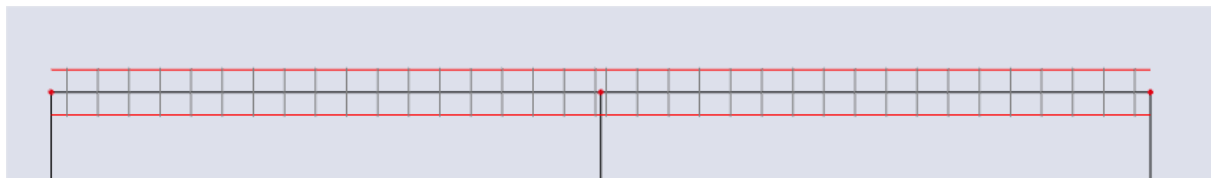

As a user, you can add locally 'New stirrups' or 'New longitudinal bars'.  
For the stirrups, you can select a certain stirrup shape:

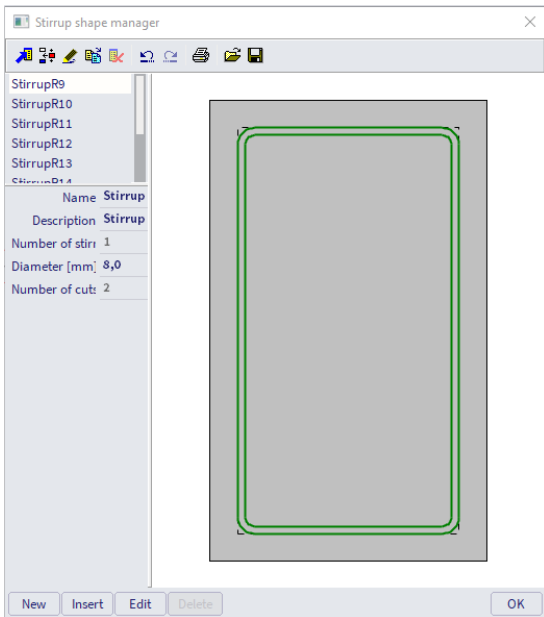

You can edit the stirrup shape, or you can make a new one. Therefore, user points must be added.

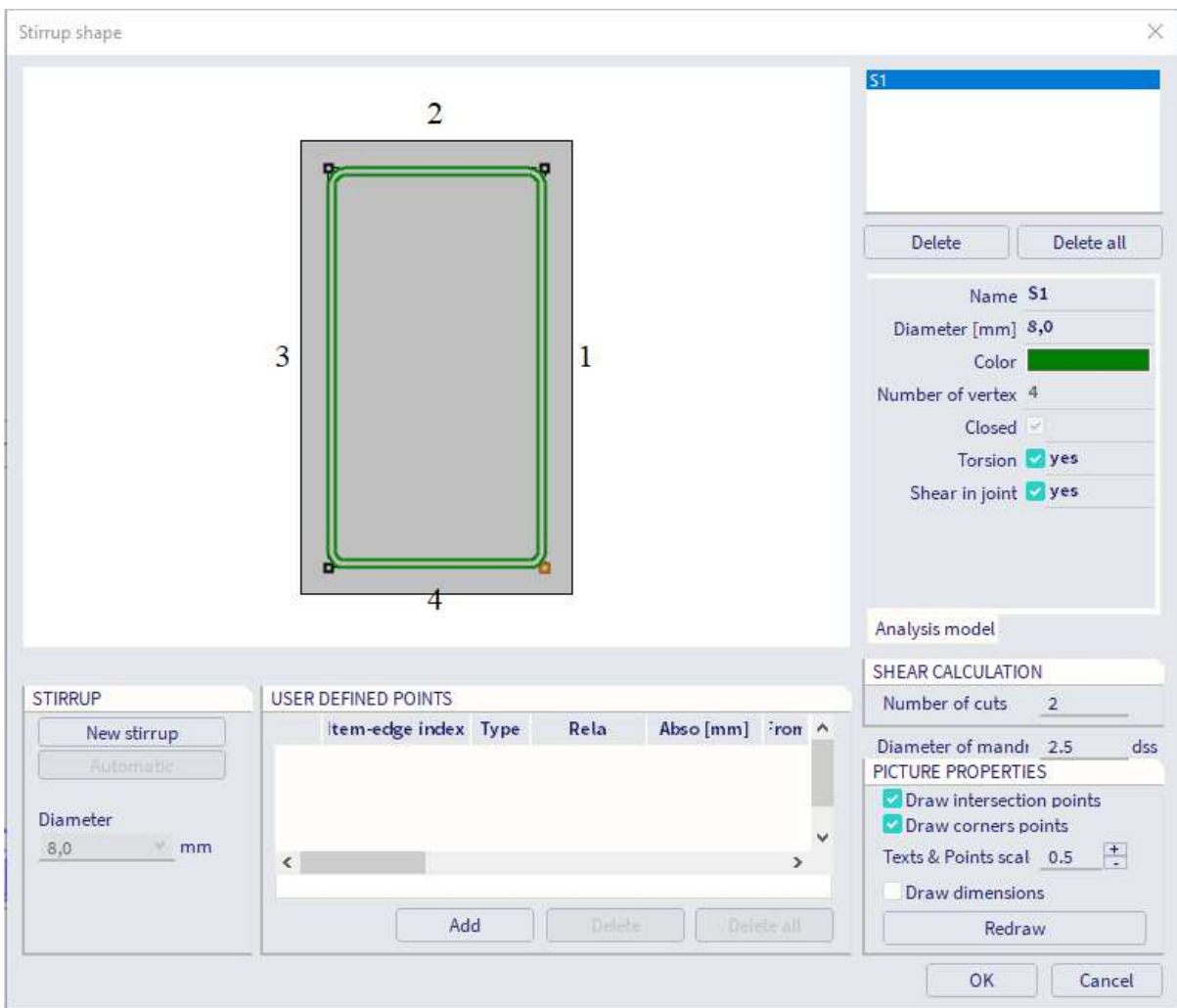

For the longitudinal reinforcement, you can define precisely where you want to place the additional practical reinforcement (with the cursor snap settings):

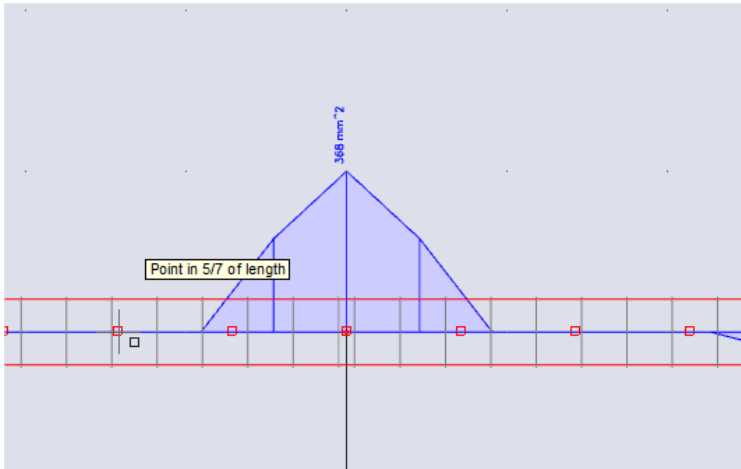

The configuration for the selected zone of the member is shown:

Member S4; Zone from 3,571 m to 6,429 m(0,357 - 0,643)

Filter: All

L1-S1E4  
L2-S1E2

Delete Delete all

Name L2-S1E2  
Position number 3  
Material B 500A ...  
Diameter [mm] 16,0  
Number of bars: 2  
Area [mm<sup>2</sup>] 402  
Layer type Uniform  
Cover type Surface to  
Cover [mm] 0,0  
Left bar Before the  
Right bar Before the

Analysis model Automatic design

REINFORCEMENT LAYERS AREA  
Selected layers 402 mm<sup>2</sup>  
All layers 804 mm<sup>2</sup>

PICTURE PROPERTIES  
 Draw dimensions  
Texts scale 0.5  
Redraw

LONGITUNAL REINFOR...  
New layer  
Add bars to corners  
Bars positions  
COLLISION OF BARS  
Collision

NEW REINFORCEMENT PARAMETERS  
Number of bars 2  
Diameter [mm] 8,0  
Stirrup name S1  
Edge index 2  
 Between existing bars  
 Move layer

TYPE OF BEAM  
beams and ribs

STIRRUPS  
Edit stirrups  
Edit cover  
Save to template

OK Cancel

Here you can set on which edge extra reinforcement needs to be added:

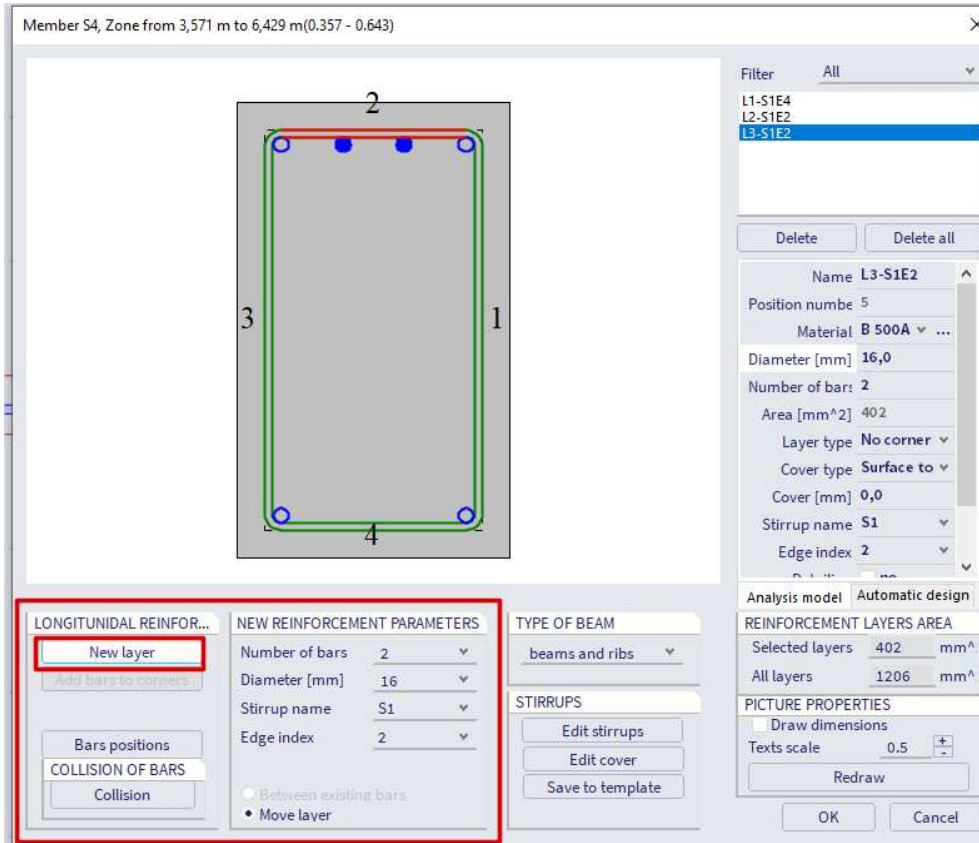

For reasons of simplicity, we will add 2 bars of 16 mm that are still needed over the whole area where extra reinforcement is required. This can of course be done more detailed. The same procedure will be repeated for the lower reinforcement (in between supports).

You also need to increase the shear reinforcement in the zone above the support. You can do this by increasing the diameter of the stirrups or by decreasing the distance between the stirrups. You can create different stirrup zones with the action 'Edit stirrup distances':

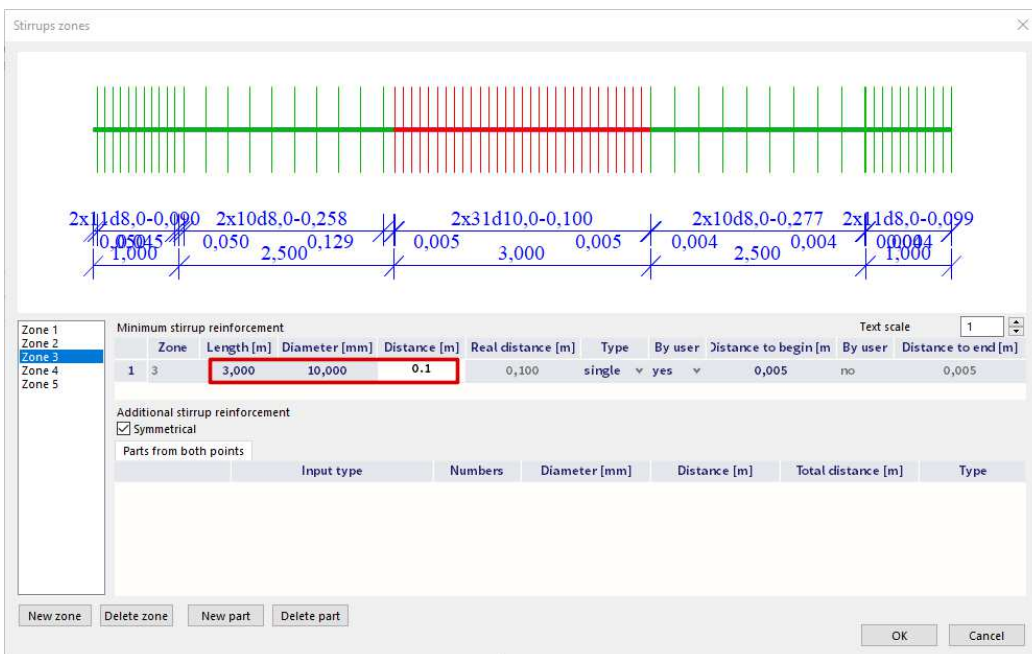

## 7.5.2. 2D members

Next to theoretical required and provided reinforcement you have also practical or user reinforcement. You can add this type of reinforcement to the 2D member via the input panel.



You have to add this reinforcement separately at the upper and lower side (each time with two reinforcement directions).

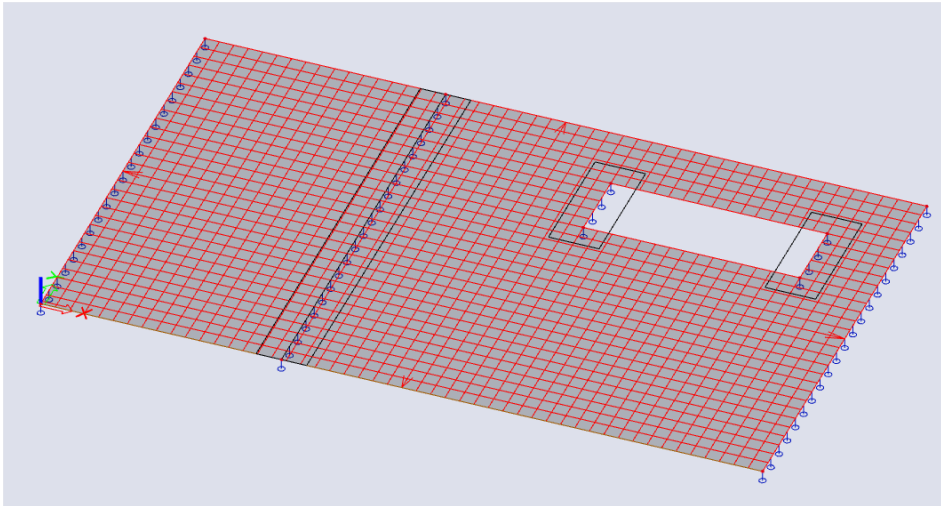

**NOTE:** you can add multiple layers of practical reinforcement on the same area. The reinforcement added to this area is the sum of all these layers.



## 7.6. 1D ULS & SLS checks

The following checks are available for 1D Members in SCIA Engineer. Requesting output from these checks is the same as in the 'Results' and 'Steel' menus and will not be explained in this chapter.

### 7.6.1. Capacity response

The 'Capacity response' check is based on the calculation of strain and stress in a particular component (concrete fibre or reinforcement bar). The check consists of the comparison of those strains and stresses with the limited values according to EN 1992-1-1 requirements.

#### Extreme values of stress/strain in component

Type of component	Fibre / Bar	$\epsilon$ [‰]	$\epsilon_{lim}$ [‰]	$\sigma$ [MPa]	$\sigma_{lim}$ [MPa]	UC [-]	Status
Concrete - compression	1	-1.63	-3.5	-18.7	-20	0.93	OK
Concrete - tension	3	2.64	0	0	0	0.00	OK
Reinforcement - compression	3	-1.16	-22.5	-233	-454	0.51	OK
Reinforcement - tension	1	2.17	22.5	434	454	0.95	OK

### 7.6.2. Capacity Diagram

The 'Capacity diagram' service uses the creation of interaction diagram (graph presenting the capacity of a concrete member to resist a set of  $N+My+Mz$ ).

This check calculates the extreme allowable interaction between the normal force  $N$  and bending moments  $My$  and  $Mz$ .

3D interaction diagram - Vertical section N-M<sub>y</sub>

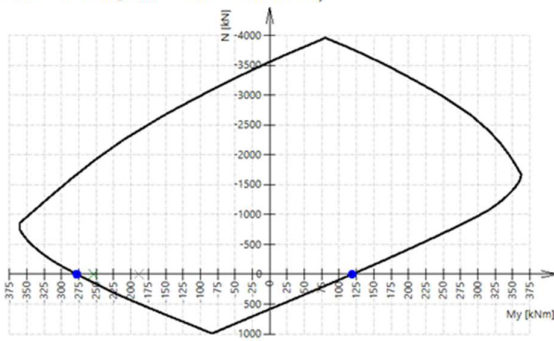

3D interaction diagram - Vertical section N-M<sub>es</sub>

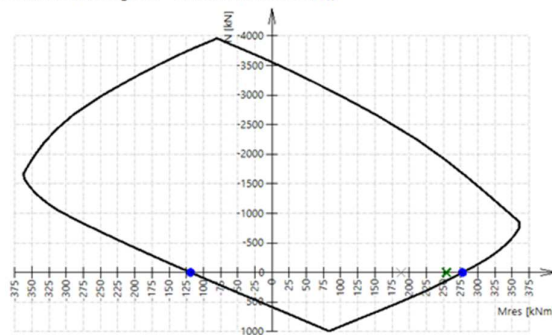

3D interaction diagram - Horizontal section M<sub>y</sub>-M<sub>z</sub>

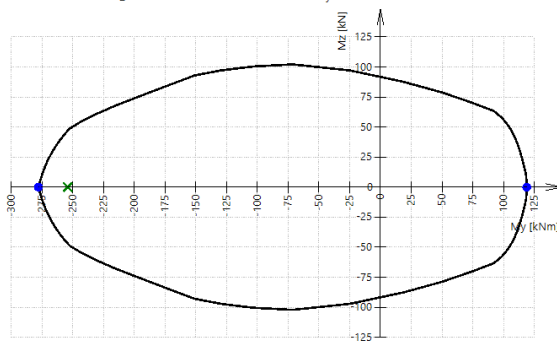

### 7.6.3. Shear + Torsion

The check of the interaction between shear and torsion consists of three checks according to clause 6.1 - 6.3 in EN 1992-1-1:

- check of shear;
- check of torsion;
- check of interaction of shear and torsion.

**Shear check**

Check  $V_{Rdmax}$

$$V_{Ed} = 152 \text{ kN} \leq V_{Rdmax} + V_{ccd} + V_{td} = 598 \text{ kN}$$

Note: The check satisfies for crushing of the compression strut ( $V_{Ed} \leq V_{Rd,max} + V_{td} + V_{ccd}$ ).

Check  $V_{Edmax}$

$$V_{Ed} = 152 \text{ kN} \leq V_{Edmax} + V_{ccd} + V_{td} = 705 \text{ kN}$$

Note: The check satisfies for shear force near the support ( $V_{Ed} \leq V_{Ed,max} + V_{td} + V_{ccd}$ ).

Check  $V_{Rdc}$  and  $V_{Rds}$

$$V_{Ed} = 152 \text{ kN} > V_{Rdc} = 87.8 \text{ kN} \text{ and } V_{Ed} = 152 \text{ kN} > V_{Rds} + V_{ccd} + V_{td} = 66.5 \text{ kN}$$

Error: The check does not satisfy, because of shear reinforcement ( $V_{Ed} > V_{Rds} + V_{ccd} + V_{td}$ ). It is necessary to increase area of shear reinforcement or to increase dimensions of the cross-section or quality of shear reinforcement.

**Unity check**

$$UC = \frac{abs(V_{Ed})}{V_{Rd}} = \frac{abs(152 \text{ kN})}{66.5 \text{ kN}} = 2.28$$

### 7.6.4. Stress limitation

The stress limitation check is based on the verification of:

- **compressive stress in the concrete:** the high value of compressive stress in concrete could lead to appearance of longitudinal cracks, spreading of micro-cracks in concrete and higher values of creep (mainly nonlinear). This effect can lead to a state where the structure is unusable.
- **tensile stress in the reinforcement:** stress in reinforcement is verified due to limitation of unacceptable strain existence and thus appearance of cracks in concrete.

**Verification of cracks in cross-section**

Load module	Type of $E_c$ [MPa]	Combi.	$N_{Ed}$ [kN]	$M_{Edy}$ [kNm]	$M_{Edz}$ [kNm]	$\sigma_{ct}$ [MPa]	$h$ [mm]	$f_{ct,eff}$ [MPa]	Cracks appear
Short	$E_c$	0 Char.	0	-188	0	12.6	500	2.9	YES

**Stress limitation in concrete**

Check type	Load	$N_{Ed}$ [kN]	$M_{Edy}$ [kNm]	$M_{Edz}$ [kNm]	$y_i$ [mm]	$z_i$ [mm]	$\sigma_c$ [MPa]	$\sigma_{c,lim}$ [MPa]	$\sigma_c/\sigma_{c,lim}$ [-]	Status
§7.2(2) Char.	Short	0	-188	0						OFF
§7.2(3) Q.-P.	Short	0	-188	0	0.15	-0.25	-21.2	-13.5	1.57	Not OK

**Stress limitation in non-prestressed reinforcement**

Check type	Load	$N_{Ed}$ [kN]	$M_{Edy}$ [kNm]	$M_{Edz}$ [kNm]	$y_i$ [mm]	$z_i$ [mm]	$\sigma_s$ [MPa]	$\sigma_{s,lim}$ [MPa]	$\sigma_s/\sigma_{s,lim}$ [-]	Status
§7.2(5) Char.	Short	0	-188	0	0.09	0.2	300	400	0.75	OK

### 7.6.5. Crack width

The crack width is calculated according to clause 7.3.4 in EN 1992-1-1.

#### Calculation of cracking forces (uncracked section)

Maximal stress in concrete

$$\sigma_{ct} = 12.6 \text{ MPa}$$

Cracking forces

$$N_{cr} = 0 \text{ kN} \quad M_{cry} = -43.3 \text{ kNm} \quad M_{crz} = 0 \text{ kNm}$$

$$\sigma_{ct} = 12.6 \text{ MPa} > \sigma_{cr} = 2.9 \text{ MPa} \Rightarrow \text{Cracks appear}$$

Note: The crack is appeared, because maximal tensile stress is greater than cracking strength.

Maximum crack spacing

$$s_{max} = 45 \text{ mm} \leq 5 \cdot (c + 0.5 \cdot \phi_{eq}) = 275 \text{ mm} \text{ or } \rho_{p,eff} = 0, \text{ therefore:}$$

$$s_{r,max} = k_3 \cdot c + \frac{k_1 \cdot k_2 \cdot k_4 \cdot \phi_{eq}}{\rho_{p,eff}} = 3.4 \cdot 0.045 + \frac{0.8 \cdot 0.5 \cdot 0.425 \cdot 0.02}{0.0428} = 232 \text{ mm} \quad (7.11)$$

Mean strain in the reinforcement

$$\epsilon_{sm,cm} = \max \left( \frac{\sigma_s - k_t \cdot \left( \frac{f_{ct,eff}}{\rho_{p,eff}} \right) \cdot (1 + \alpha_E \cdot \rho_{p,eff})}{E_s}, \frac{0.6 \cdot \sigma_s}{E_s} \right) \quad (7.9)$$

$$= \max \left( \frac{300 \cdot 10^6 - 0.46 \cdot \left( \frac{2.9 \cdot 10^6}{0.0428} \right) \cdot (1 + 6.06 \cdot 0.0428)}{200 \cdot 10^9}, \frac{0.6 \cdot 300 \cdot 10^6}{200 \cdot 10^9} \right) = 1.3 \text{ ‰}$$

Calculated crack width

$$w = \epsilon_{sm,cm} \cdot s_{r,max} = 1.3 \cdot 232 = 0.303 \text{ mm} \quad (7.8)$$

#### Limit value of crack width

$$w_{max} = 0.4 \text{ mm}$$

## 7.6.6. Deflection

The calculation of deflection is done according to chapter 7.4.3 from EN 1992-1-1.

The simplified method is used where the calculation is done twice, assuming the whole member to be uncracked and fully cracked, and then interpolating formula 7.18 according to clause 7.4.3(7). This is the default used method.

### Deflections

#### Linear deflection

$$\delta_{lin,y} = u_{y5} + u_{y1} = 0 + 0 = 0 \text{ mm}$$

$$\delta_{lin,z} = u_{z5} + u_{z1} = 0 + -3.08 = -3.08 \text{ mm}$$

#### Immediate deflection

$$\delta_{imm,y} = u_{y1} \cdot \text{ratio}_{u_{y5}} = 0 \cdot 2.88 = 0 \text{ mm}$$

$$\delta_{imm,z} = u_{z1} \cdot \text{ratio}_{u_{z5}} = -3.08 \cdot 2.5 = -7.7 \text{ mm}$$

#### Short-term deflection

$$\delta_{short,y} = u_{y5} \cdot \text{ratio}_{u_{y5}} = 0 \cdot 2.88 = 0 \text{ mm}$$

$$\delta_{short,z} = u_{z5} \cdot \text{ratio}_{u_{z5}} = 0 \cdot 2.5 = 0 \text{ mm}$$

#### Long-term + creep deflection

$$\delta_{long,creep,y} = u_{y1} \cdot \text{ratio}_{u_{y1}} = 0 \cdot 5.22 = 0 \text{ mm}$$

$$\delta_{long,creep,z} = u_{z1} \cdot \text{ratio}_{u_{z1}} = -3.08 \cdot 3.38 = -10.4 \text{ mm}$$

#### Creep deflection

$$\delta_{creep,y} = u_{y1} \cdot (\text{ratio}_{u_{y1}} - \text{ratio}_{u_{y5}}) = 0 \cdot (5.22 - 2.88) = 0 \text{ mm}$$

$$\delta_{creep,z} = u_{z1} \cdot (\text{ratio}_{u_{z1}} - \text{ratio}_{u_{z5}}) = -3.08 \cdot (3.38 - 2.5) = -2.69 \text{ mm}$$

#### Long-term deflection

$$\delta_{long,y} = \delta_{long,creep,y} - \delta_{creep,y} = 0 - 0 = 0 \text{ mm}$$

$$\delta_{long,z} = \delta_{long,creep,z} - \delta_{creep,z} = -10.4 - -2.69 = -7.7 \text{ mm}$$

#### Additional deflection

$$\delta_{add,y} = \delta_{short,y} + \delta_{long,creep,y} - \delta_{imm,y} = 0 + 0 - 0 = 0 \text{ mm}$$

$$\delta_{add,z} = \delta_{short,z} + \delta_{long,creep,z} - \delta_{imm,z} = 0 + -10.4 - -7.7 = -2.69 \text{ mm}$$

#### Limit additional deflection

$$\delta_{add,lim,y} = 0 \text{ mm}$$

$$\delta_{add,lim,z} = \frac{-l_{0z}}{\text{Lim}_{add}} = \frac{-10}{500} = -20 \text{ mm}$$

#### Total deflection

$$\delta_{tot,y} = \delta_{short,y} + \delta_{long,creep,y} = 0 + 0 = 0 \text{ mm}$$

$$\delta_{tot,z} = \delta_{short,z} + \delta_{long,creep,z} = 0 + -10.4 = -10.4 \text{ mm}$$

#### Limit total deflection

$$\delta_{tot,lim,y} = 0 \text{ mm}$$

$$\delta_{tot,lim,z} = \frac{-l_{0z}}{\text{Lim}_{tot}} = \frac{-10}{250} = -40 \text{ mm}$$

## 7.7. 2D Crack width check

For 2D Members there are fewer checks: the crack width check and the punching check.

The values of the maximum crack width ( $w_{max}$ ) are national determined parameters, depending on the chosen exposure class. Therefore, you can find this value in the setup for National Determined Parameters, via **File** → **Project settings** → **National annex** [...] → **EN 1992-1-1** [...].

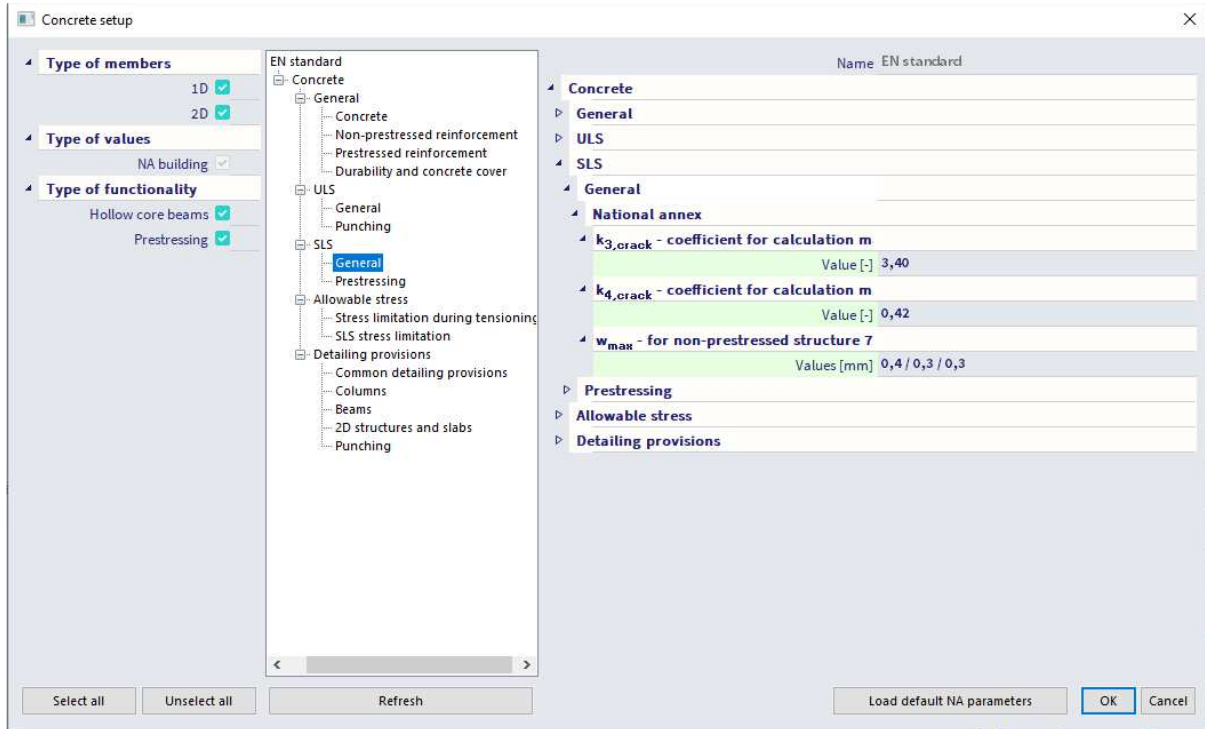

### 7.7.1. Type of used reinforcement

You can perform the 'Crack width check' for all three types of reinforcement: required, provided and user reinforcement. The crack width check is performed on a quasi-permanent SLS combination.

If you use as type of reinforcement for the crack width either the provided or required reinforcement, you should choose a ULS combination as well. This is necessary because the required/provided reinforcement is calculated based on at least an ULS combination. After this reinforcement is calculated, it can be used to perform the crack width check (this is done automatically by the software).

#### Required/provided reinforcement

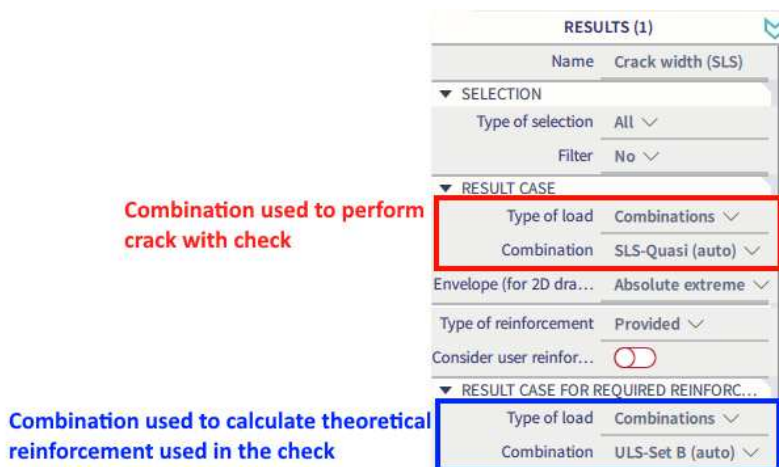

User reinforcement

Combination used to perform crack width check

Amount of reinforcement is already known, so no ULS combination necessary



Crack width  $w_+$

Combination = SLS; Type of used reinforcement = Required; Value =  $w_+$

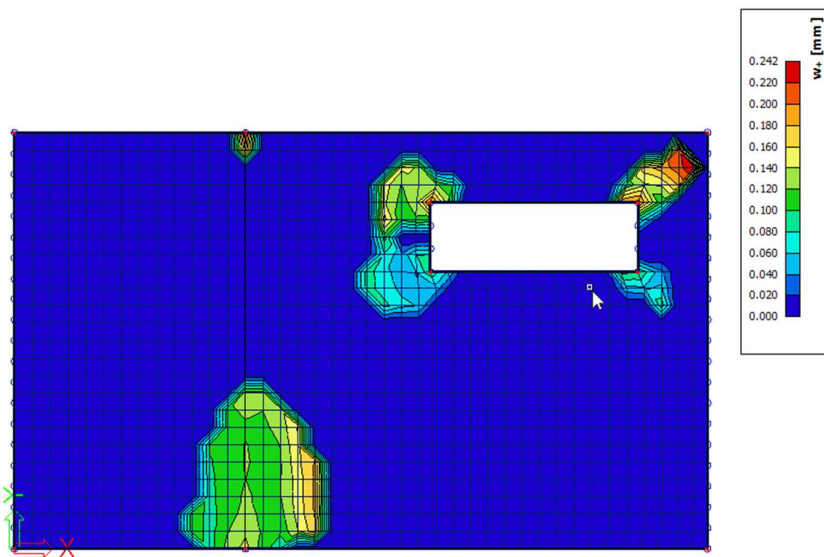

Crack width  $w_-$

Combination = SLS; Type of used reinforcement = Required; Value =  $w_-$

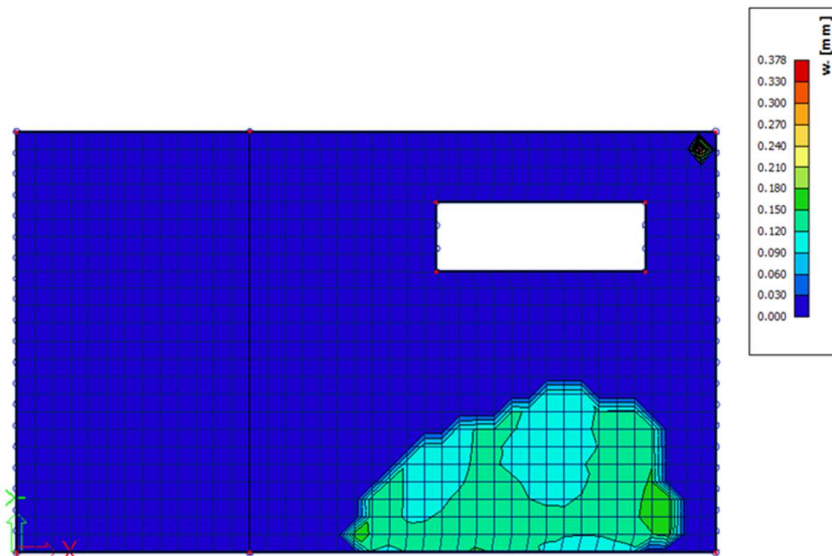



## Unity check

Combination = SLS; Type of used reinforcement = Required; Value = **UC**

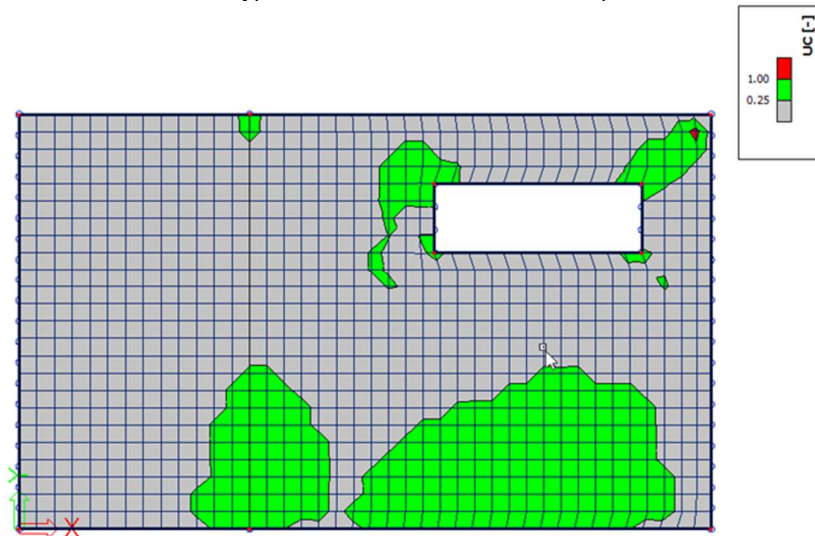

## 7.8. Punching check

You can find the punching design in the **Design → ULS punching**.

The beta factor is automatically calculated, and the shape of the column is automatically recognized. You can choose the method for determining the beta factor in the concrete settings.

Before performing the punching design, you need to set the property panel. Here you need to choose the type of reinforcement (this is the same as for the crack width check).

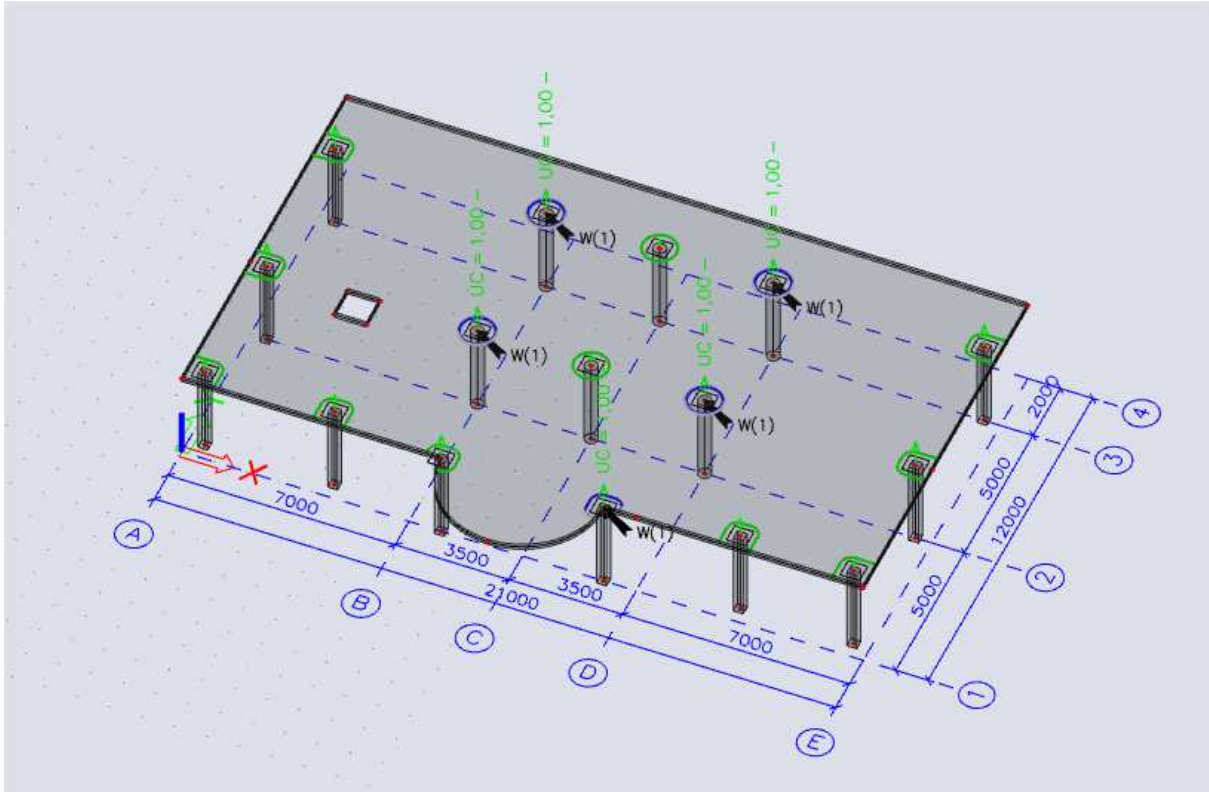

There are three different types of results:

- **Green visualization:** the concrete can take the concentrated load.

**Punching design**  
 Linear calculation  
 Combination: ULS  
 Extreme: Global  
 Selection: N61  
**Summary**

Name	Case	Punching case	Punching shape	UC v <sub>Rd,max</sub> [-]	UC v <sub>Rd,c</sub> [-]	Shear reinforcement perimeters	UC v <sub>Rd,cs</sub> [-]	UC A <sub>sw,det</sub> [-]	UC [-] Check
N61	ULS/1	Internal column	Circle (400)	<b>0,17</b>	<b>0,52</b>	not required	-	-	0,52 OK

**Concrete**

Name	Case	Punching case	Punching shape	V <sub>Ed</sub> [kN] β [-]	M <sub>Ed,y</sub> [kNm] M <sub>Ed,z</sub> [kNm]	Plate h [mm]	Material f <sub>cd</sub> [MPa]	d <sub>eff</sub> [mm] ρ <sub>1</sub> [%]	U <sub>0</sub> [m] U <sub>1</sub> [m]	V <sub>Ed,u0</sub> [MPa] V <sub>Ed,u1</sub> [MPa]	V <sub>Rd,max</sub> [MPa] V <sub>Rd,c</sub> [MPa]	UC v <sub>Rd,max</sub> [-] UC v <sub>Rd,c</sub> [-]
N61	ULS/1	Internal column	Circle (400)	<b>128,46</b> 1,15	0,09 13,98	Ceiling 200,00	C30/37 20,00	160,00 0,18	1,257 3,267	0,73 0,28	4,22 0,55	<b>0,17</b> <b>0,52</b>

- **Blue visualization:** the concrete cannot take the concentrated load but punching reinforcement can be designed.

**Punching design**  
 Linear calculation  
 Combination: ULS  
 Extreme: Global  
 Selection: N59  
**Summary**

Name	Case	Punching case	Punching shape	UC v <sub>Rd,max</sub> [-]	UC v <sub>Rd,c</sub> [-]	Shear reinforcement perimeters	UC v <sub>Rd,cs</sub> [-]	UC A <sub>sw,det</sub> [-]	UC [-] Check
N59	ULS/1	Internal column	Circle (400)	<b>0,36</b>	<b>1,06</b>	3x 12Ø8(radial) 80+2x80=240	<b>0,71</b>	<b>1,00</b>	1,00 OK, BUT

**Concrete**

Name	Case	Punching case	Punching shape	V <sub>Ed</sub> [kN] β [-]	M <sub>Ed,y</sub> [kNm] M <sub>Ed,z</sub> [kNm]	Plate h [mm]	Material f <sub>cd</sub> [MPa]	d <sub>eff</sub> [mm] ρ <sub>1</sub> [%]	U <sub>0</sub> [m] U <sub>1</sub> [m]	V <sub>Ed,u0</sub> [MPa] V <sub>Ed,u1</sub> [MPa]	V <sub>Rd,max</sub> [MPa] V <sub>Rd,c</sub> [MPa]	UC v <sub>Rd,max</sub> [-] UC v <sub>Rd,c</sub> [-]
N59	ULS/1	Internal column	Circle (400)	<b>265,21</b> 1,15	26,85 6,10	Ceiling 200,00	C30/37 20,00	160,00 0,38	1,257 3,267	1,52 0,58	4,22 0,55	<b>0,36</b> <b>1,06</b>

**Reinforcement**

Name	Case	Shear reinforcement perimeters	U <sub>out</sub> [m] a <sub>out</sub> [mm]	S <sub>cut</sub> [mm] S <sub>out</sub> [mm]	Control perimeters (distance/capacity)	Material f <sub>ywd,eff</sub> [MPa]	A <sub>sw,req</sub> [mm <sup>2</sup> ] A <sub>sw,min</sub> [mm <sup>2</sup> ]	A <sub>sw</sub> [mm <sup>2</sup> ] A <sub>sw,tot</sub> [mm <sup>2</sup> ]	V <sub>Rd,cs</sub> [MPa] K <sub>max</sub> V <sub>Rd,c</sub> [MPa]	UC v <sub>Rd,cs</sub> [-] UC A <sub>sw,det</sub> [-]
N59	ULS/1	3x 12Ø8(radial) 80+2x80=240	3,472 354	230 230	320/71%	B 500B 290,0	103 11	603 <b>1810</b>	1,42 0,82	<b>0,71</b> <b>1,00</b>

- **Red visualization:** the concrete cannot take the concentrated load and punching reinforcement cannot be designed.

**Punching design**  
 Linear calculation  
 Combination: ULS  
 Extreme: Global  
 Selection: N20  
**Summary**

Name	Case	Punching case	Punching shape	UC v <sub>Rd,max</sub> [-]	UC v <sub>Rd,c</sub> [-]	Shear reinforcement perimeters	UC v <sub>Rd,cs</sub> [-]	UC A <sub>sw,det</sub> [-]	UC [-] Check
N20	ULS/1	Corner column	Rectangle (300;300)	<b>0,86</b>	<b>1,01</b>	3x 9Ø8(radial) 80+2x80=240	<b>0,68</b>	<b>3,00</b>	3,00 NOT OK

**Concrete**

Name	Case	Punching case	Punching shape	V <sub>Ed</sub> [kN] β [-]	M <sub>Ed,y</sub> [kNm] M <sub>Ed,z</sub> [kNm]	Plate h [mm]	Material f <sub>cd</sub> [MPa]	d <sub>eff</sub> [mm] ρ <sub>1</sub> [%]	U <sub>0</sub> [m] U <sub>1</sub> [m]	V <sub>Ed,u0</sub> [MPa] V <sub>Ed,u1</sub> [MPa]	V <sub>Rd,max</sub> [MPa] V <sub>Rd,c</sub> [MPa]	UC v <sub>Rd,max</sub> [-] UC v <sub>Rd,c</sub> [-]
N20	ULS/1	Corner column	Rectangle (300;300)	<b>139,68</b> 1,50	19,42 6,98	Ceiling 200,00	C30/37 20,00	160,00 0,30	0,359 2,362	3,65 0,55	4,22 0,55	<b>0,86</b> <b>1,01</b>

**Reinforcement**

Name	Case	Shear reinforcement perimeters	U <sub>out</sub> [m] a <sub>out</sub> [mm]	S <sub>cut</sub> [mm] S <sub>out</sub> [mm]	Control perimeters (distance/capacity)	Material f <sub>ywd,eff</sub> [MPa]	A <sub>sw,req</sub> [mm <sup>2</sup> ] A <sub>sw,min</sub> [mm <sup>2</sup> ]	A <sub>sw</sub> [mm <sup>2</sup> ] A <sub>sw,tot</sub> [mm <sup>2</sup> ]	V <sub>Rd,cs</sub> [MPa] K <sub>max</sub> V <sub>Rd,c</sub> [MPa]	UC v <sub>Rd,cs</sub> [-] UC A <sub>sw,det</sub> [-]
N20	ULS/1	3x 9Ø8(radial) 80+2x80=240	2,395 328	222 222	320/68%	B 500B 290,0	63 10	452 <b>1357</b>	1,45 0,82	<b>0,68</b> <b>3,00</b>



## 7.9. Code dependent deformations

The 'Code dependent deformations' calculation is a semi-linear calculation and can be found in **Design** → **Code dependent deflection**. The calculation is performed, stiffnesses are reduced and the calculation is performed another time with these reduced stiffnesses to find non-linear deformations. This explanation is simplified. In the concrete manual you can find the full explanation. Below you can see the values calculated by this type of calculation.

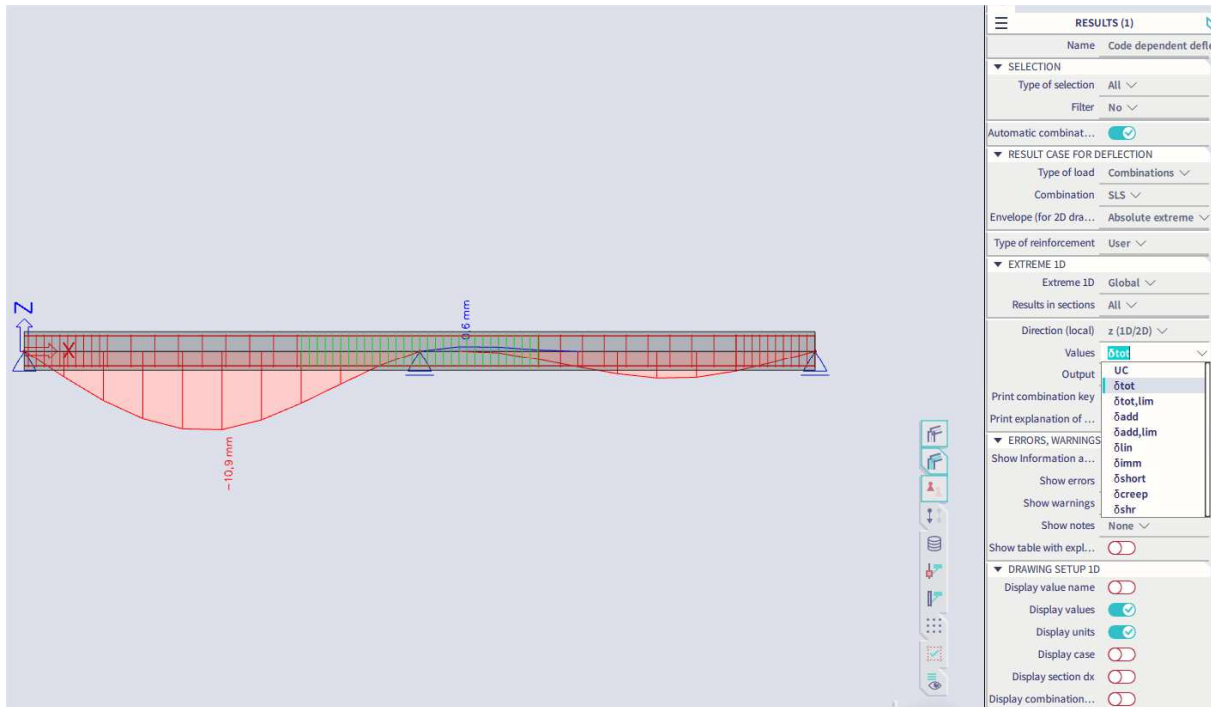

For 1D member

Name	dx [m]	Case Type of reinf.	$\varphi(t, t_0)$ [-] $\epsilon_{cs}(t, t_s)$ [1e-4]	$\delta_{lin,y}$ [mm]	$\delta_{imn,y}$ [mm]	$\delta_{short,y}$ [mm]	$\delta_{creep,y}$ [mm]	$\delta_{shr,y}$ [mm]	$\delta_{add,y}$ [mm]	$\delta_{add,lim,y}$ [mm]	$\delta_{tot,y}$ [mm]	$\delta_{tot,lim,y}$ [mm]	UC [-] Check
S1	2,500+	SLS/1 User	2,21 -	0,0 -3,4	0,0 -6,8	0,0 -8,0	0,0 -2,8	-	0,0 -4,1	20,0 10,0	0,0 -10,9	40,0 20,0	0,54 OK
S1	5,500+	SLS/2 User	2,21 -	0,0 0,2	0,0 0,5	0,0 0,5	0,0 0,1	-	0,0 0,1	20,0 10,0	0,0 0,6	40,0 20,0	0,03 OK



## Chapter 8: Engineering report

### 8.1. General interface

The general interface of the engineering report consists of 5 different windows. You can modify the layout of the interface to your own demands by dragging these windows to the desired position. The windows are shown in the following picture provided by an explanation of its purposes.

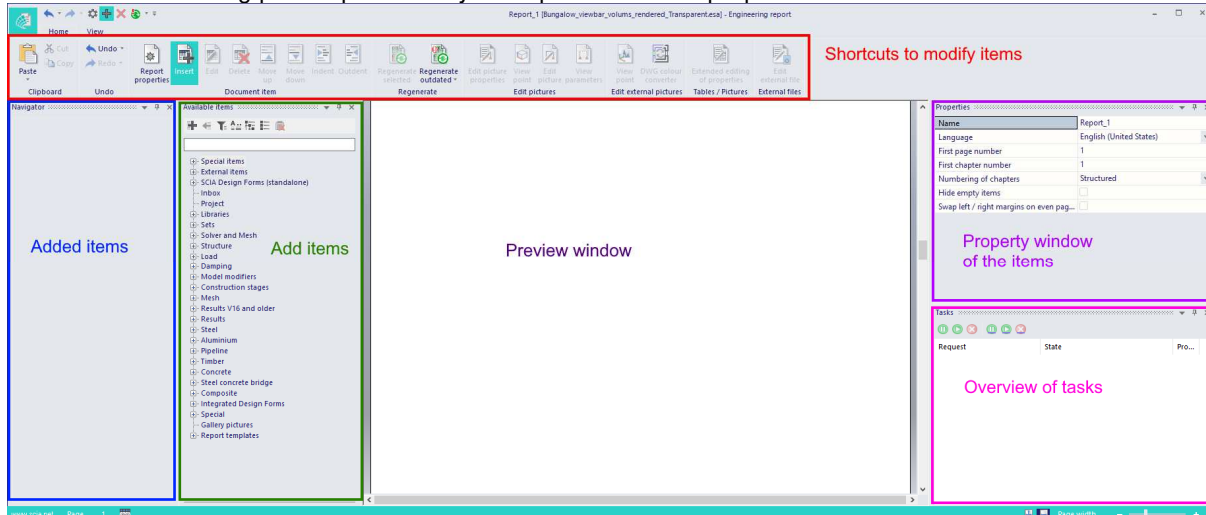

The engineering report works with items. These items contain all the information that is available in SCIA Engineer. To add an item into the report, you should double click on the item in the window 'Available items' or type the item's name into the search box of the available items. As soon as you have added this item, it will be displayed in the tab 'Navigator' or 'Added items' in the previous picture. You can always change the added items by using the properties window, which is based on the same principle as in the model space of SCIA Engineer. You can also modify inserted pictures by using the shortcuts 'Edit picture properties', 'View point', ... which are shown in the following picture.

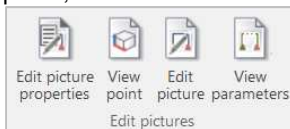

After modifying one or multiple added items, you have to regenerate the content of the report. You can execute this command for an individual item as well as for the entire report by using the shortcuts 'Regenerate selected' or 'Regenerate outdated'.



You can use the shortcut 'Edit' to customize the advanced properties of the added items.



You can modify the language of the report, both in- and output, by adjusting the language in the properties window of the engineering report.

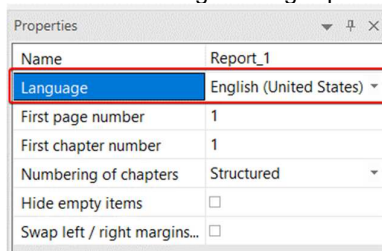

## 8.2. General page layout

The following chapter contains an explanation of several items concerning the general page layout of the engineering report.

### 8.2.1. Page layout

You can select the subitem 'Style' to modify the page layout of the report. You can find this item as a subitem of the available item 'Special items'. When you have added this item to the report, you can select the shortcut 'Edit'. Then the style editor will open. This editor allows you to modify all the settings concerning the fonts, the spacings and the colours of the text in the report.

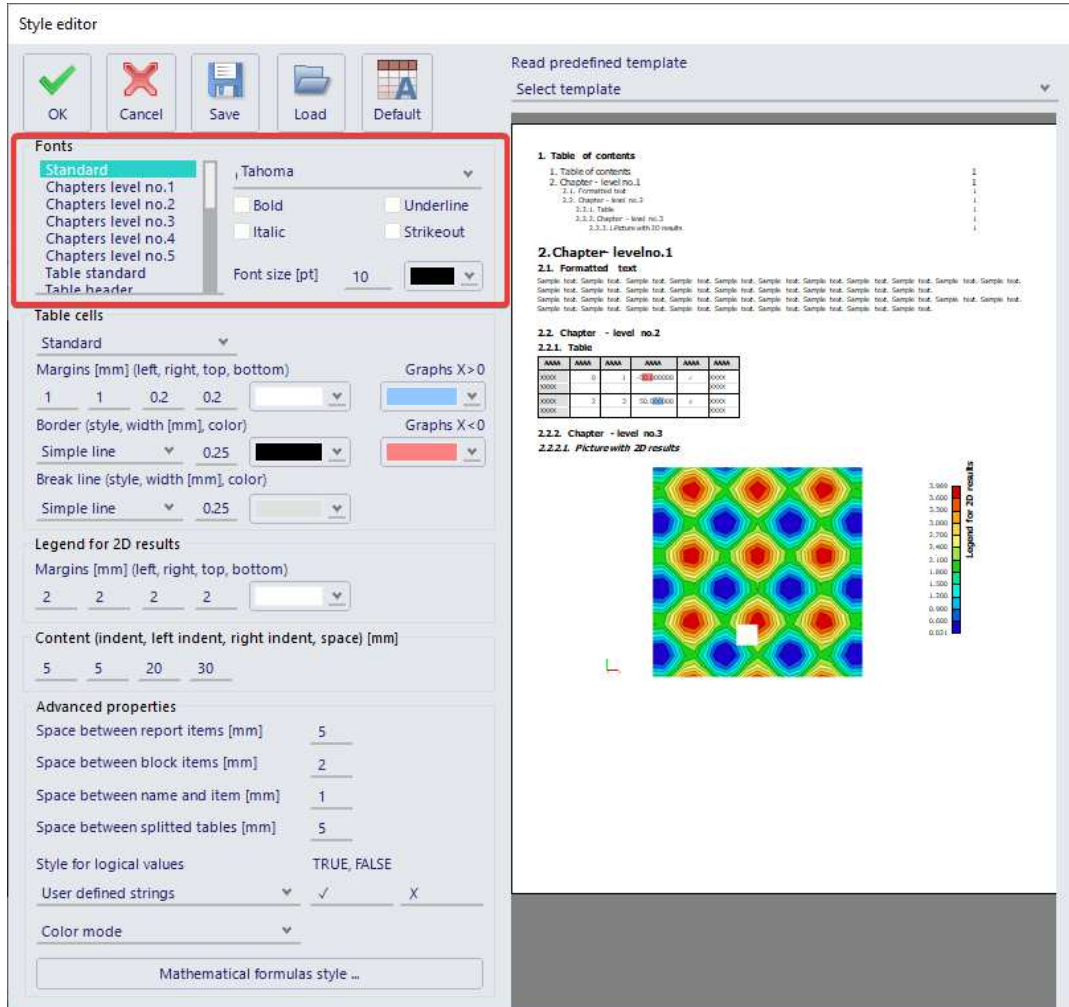

## 8.2.2. Page format and page break

You can adjust the page format of the report by inserting the item **'Page format'**. This item is a subcategory of the item **'Special items'**. It also contains the item **'Page break'** by which you can define the end of a page, for example at the end of a chapter.

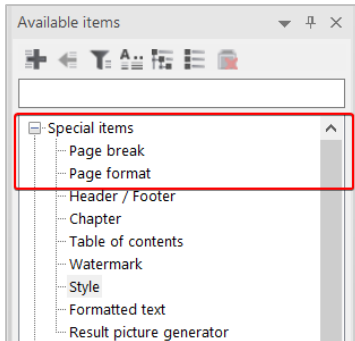

When you have inserted the item **'Page format'**, you can define all its settings – the format and the margins – in the properties window.

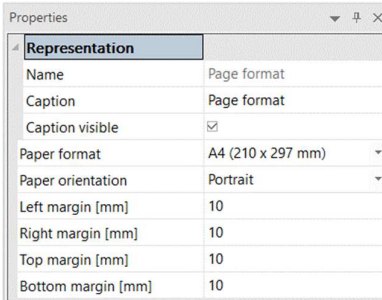

### 8.2.3. Header and footer

You can find the item **'Header / Footer'** in the category **'Special items'**. Activating the shortcut **'Edit'** allows you to define a completely customized header and footer for your report. You can save this item as a template and apply it in other reports as well.

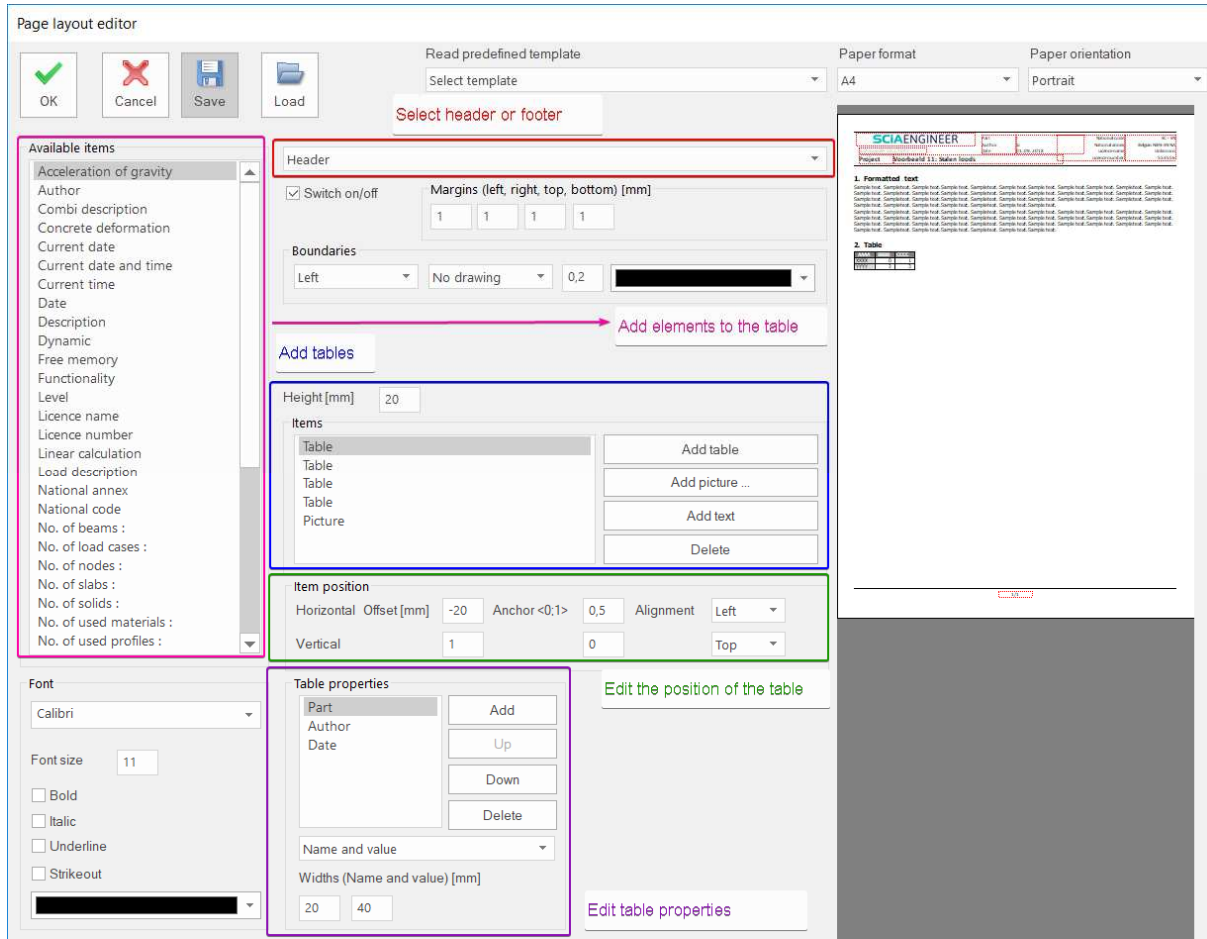

### 8.2.4. Chapter

You can create several chapters in the engineering report by adding the special item **'Chapter'** into the report.

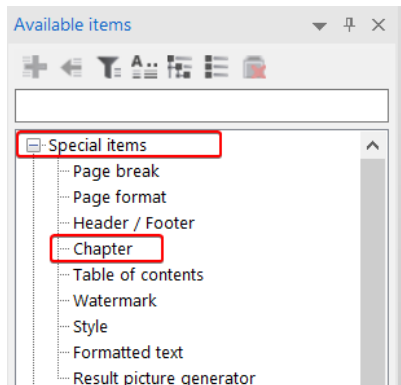

## 8.2.5. Formatted text

With the special item '**Formatted text**' you can input text in the engineering report manually.

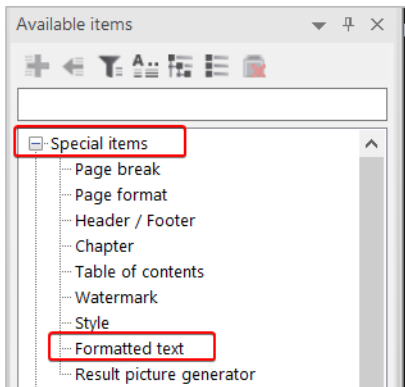

As soon as you have added this item to the report and you have chosen the command '**Edit**', you can insert text in the editor window.

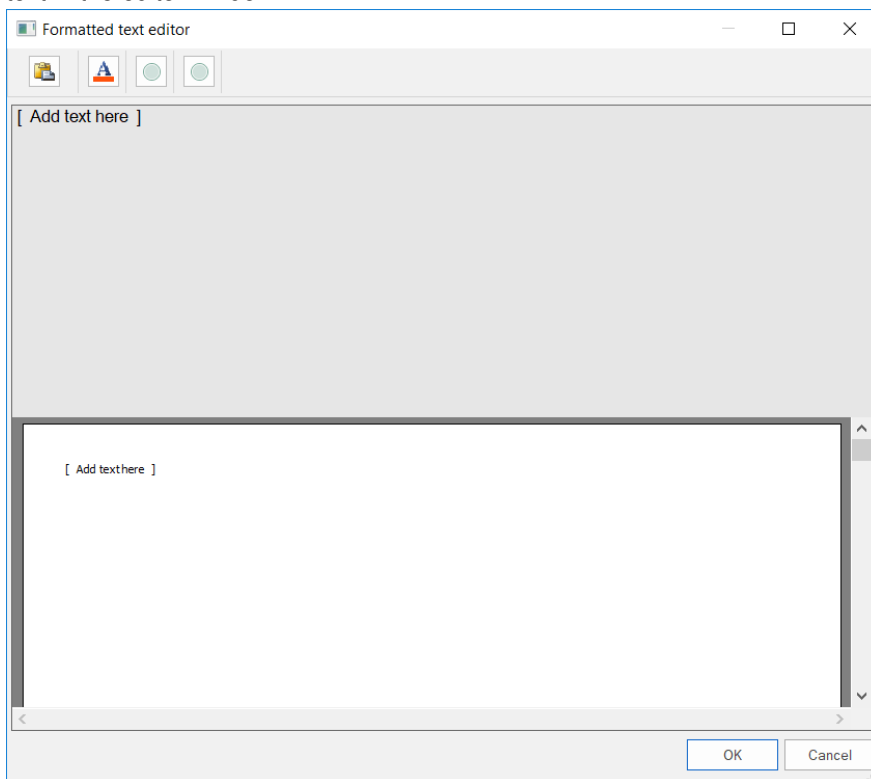

### 8.3. Adding pictures

You can also add pictures to the engineering report. You have different methods to insert these items. We explain these methods in this chapter.

#### 8.3.1. Screenshot or live pictures

As first option to insert pictures into the report you can use the commands **'Screenshot into Engineering report'**, **'Live picture in scale into Engineering report'** and **'Live picture into Engineering report'**. These commands allow you to send pictures of the model to the report and you can access it by right clicking in SCIA Engineer.

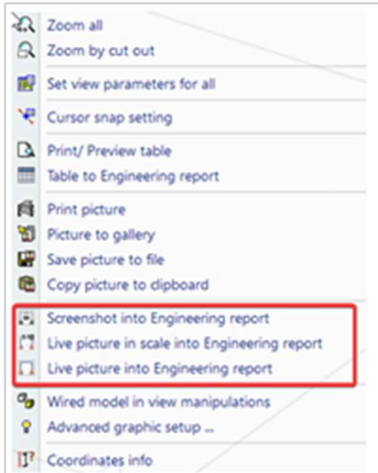

However, it is important that you are aware of the difference between both types of picture. A screenshot is a fixed shot, meaning it will **not** be updated when you modify the structure. Both types of live pictures will be updated when you modify the structure. You can add the picture into the report by executing the command **'Insert & Close'**.

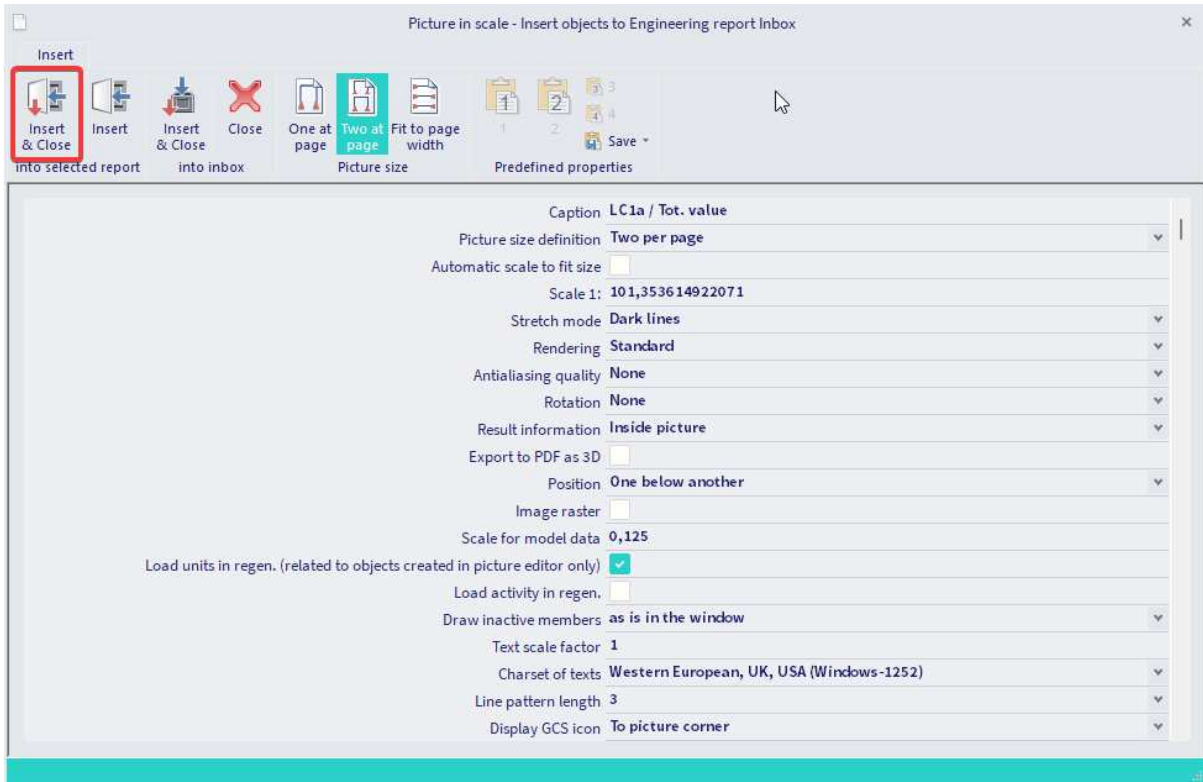



### 8.3.2. Inbox

You can send live pictures or screenshots to the **'Inbox'** of the engineering report instead of immediately into the report. This option allows you to insert the generated pictures into the report in a later stage. To send them to the inbox, you should choose the command **'Insert & Close'** in the tab **'into Inbox'**.

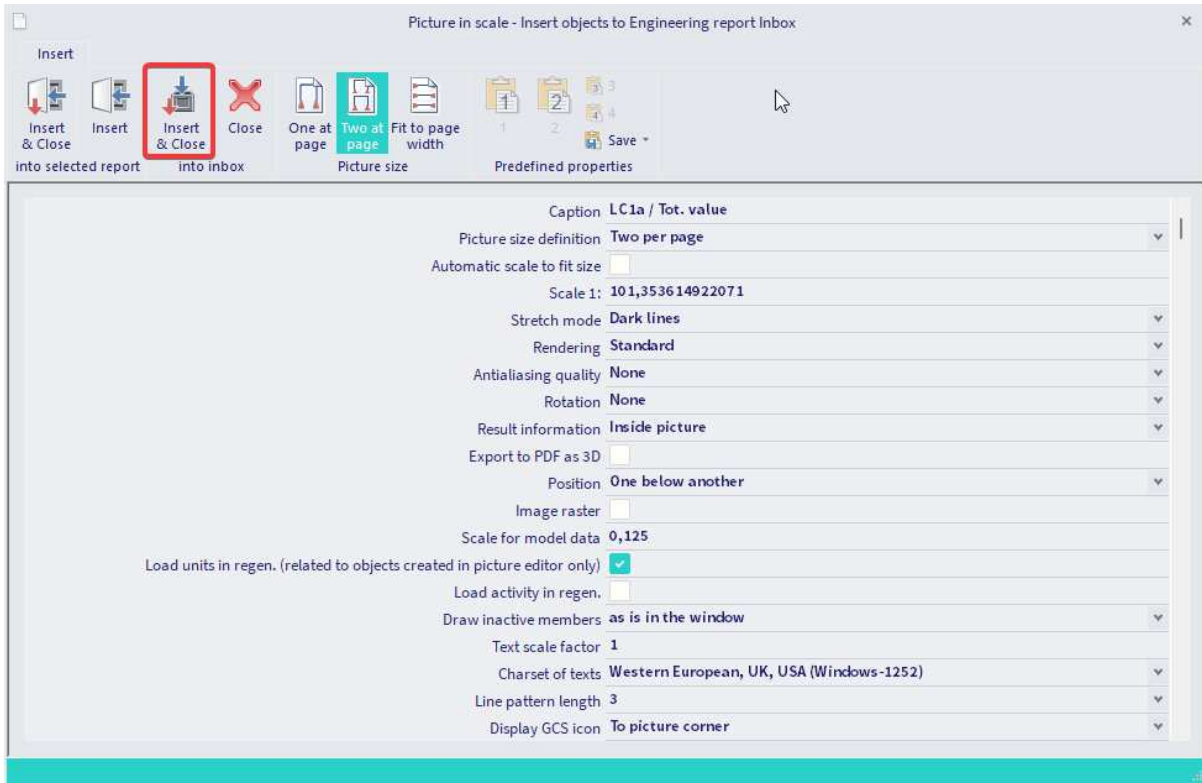

### 8.3.3. Picture gallery

You can send pictures, generated in the model space, to the picture gallery as well. This option allows you to edit the generated picture without adding data – for example dimension lines – to the model.

You can access the picture gallery by selecting it via the **Main Menu → Libraries → Image gallery**.



You can send a picture into the picture gallery by performing a right click in the graphical window and selecting the option **'Image to gallery'**.

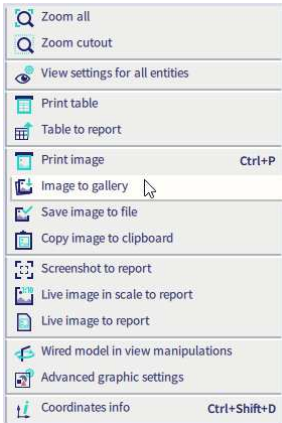

As mentioned before, you can modify the picture in the picture gallery without adding data to the model in the model space. To modify the picture, you should activate the option **'Edit'** in the gallery.

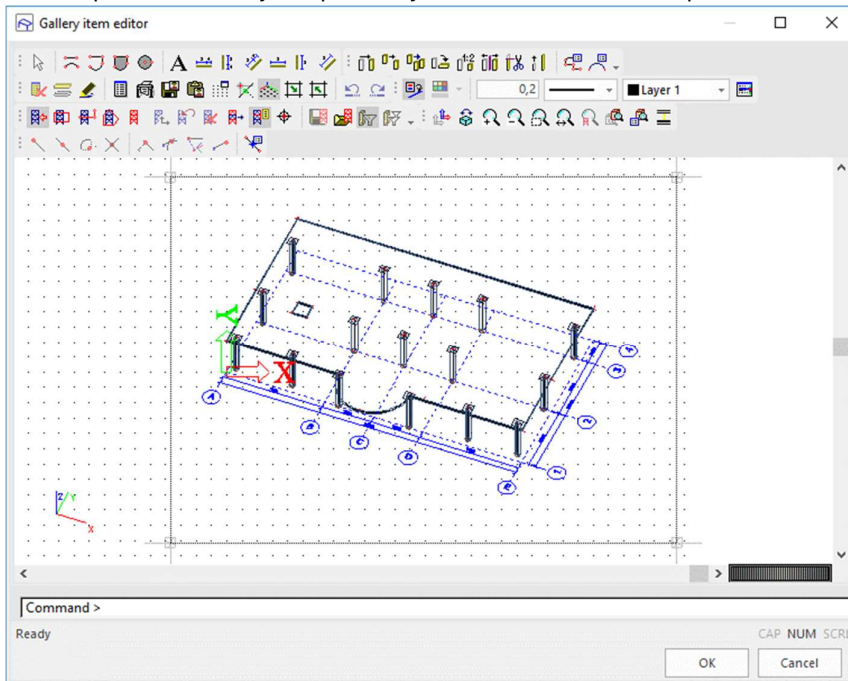

You can add pictures from the picture gallery to the engineering report by selecting the available item **'Gallery pictures'**.

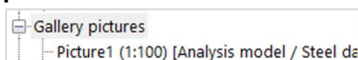

### 8.3.4. Paperspace gallery

The Paperspace allows you to create a plan view of the model.

You can access the Paperspace gallery by selecting it via the **Main Menu → Libraries → Paperspace gallery**.



After you have created a new paperspace gallery picture, you can add several items by applying the following functions:

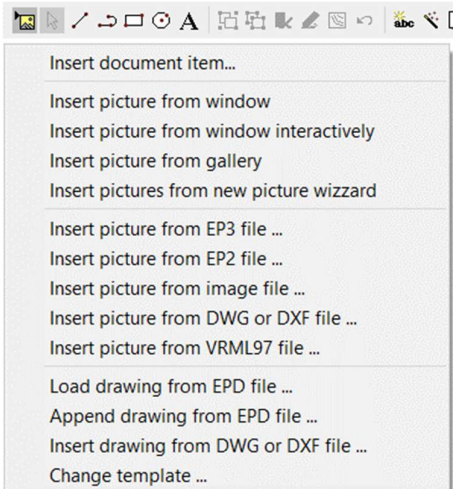

### 8.3.5. Generating result pictures

To create pictures concerning the results of the executed calculation, you have two possibilities: using the shortcut **'Indent'** or adding the **'Result picture generator'**. Both options are explained below.

#### 8.3.5.1. Indenting

While composing an engineering report, you can execute the command **'Indent'**. By activating this command, meaning indenting a table or a picture under an item, SCIA automatically recognizes the relations between those items and generates the output according to these settings. The following pictures provide a graphical representation of an indented image under a load case.

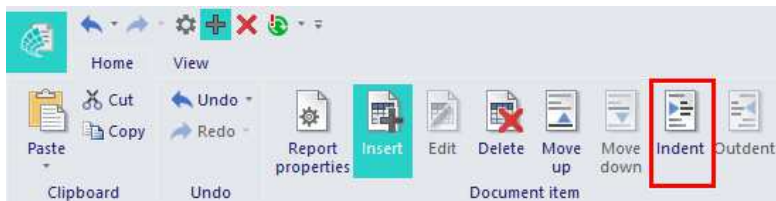

1.2. Load cases - BG2

Name	Description	Action type	Load group
	Spice	Load type	
BC2	Dakbelaag	Permanent Standard	LG1

1.2.1. BG3 / Tot. value

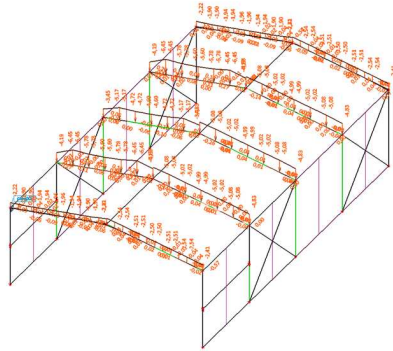

1.3. Load cases - BG3

Name	Description	Action type	Load group	Duration	Master load case
	Spice	Load type			
BC3	Wind X Standard	Variable Static	LG2	Short	None

1.3.1. BG3 / Tot. value

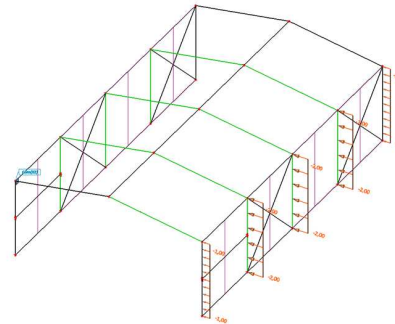

### 8.3.5.2. Result picture generator

The result picture generator is an item which you can find under **'Special items'**. This item requires an indented result table and an indented live picture.

The result picture generator:

- takes the information about the results from the result table;
- takes the viewpoint of the image;
- views the result set in its properties.

You should define in the properties window of the generator which results need to show in a picture. In the following example, pictures for the selected results 'N', 'M<sub>x</sub>' and 'M<sub>y</sub>' will be generated.

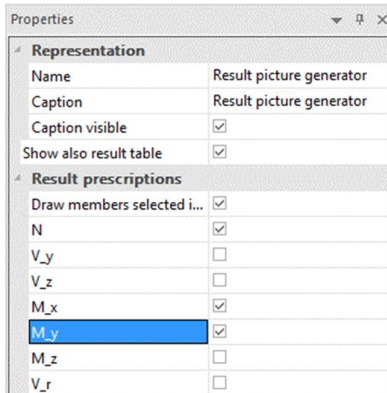

## 1. Result picture generator

### 1.1. 1D internal forces

Linear calculation  
 Load case: BG1  
 Coordinate system: Principal  
 Extreme 1D: Global  
 Selection: All

Name	dx [m]	Case	N [kN]	V <sub>y</sub> [kN]	V <sub>z</sub> [kN]	M <sub>x</sub> [kNm]	M <sub>y</sub> [kNm]	M <sub>z</sub> [kNm]
S8	0,000	BG1	<b>-5,62</b>	0,07	0,78	0,00	0,00	-0,20
S22	0,000	BG1	<b>0,08</b>	0,00	-0,12	0,00	-0,10	0,00
S36	7,071	BG1	-0,45	<b>-0,12</b>	-0,12	0,00	-0,14	-0,15
S35	0,000	BG1	-0,42	<b>0,12</b>	0,12	0,00	-0,15	-0,14
S5	2,500+	BG1	-4,21	0,03	<b>-0,78</b>	0,00	-1,95	0,10
S3	0,000	BG1	-1,16	-0,01	2,41	<b>0,00</b>	-3,73	0,00
S2	0,000	BG1	-1,16	0,01	2,41	<b>0,00</b>	-3,73	0,00
S7	0,000	BG1	-1,21	0,00	<b>2,49</b>	0,00	<b>-3,91</b>	-0,01
S8	5,000	BG1	-2,97	0,04	0,78	0,00	<b>3,90</b>	0,20
S20	5,000	BG1	-2,77	-0,10	0,74	0,00	3,72	<b>-0,31</b>
S16	5,000	BG1	-2,95	0,08	0,78	0,00	3,90	<b>0,21</b>

### 1.2. BG3 / Tot. value - N

Values: N  
 Linear calculation  
 Load case: BG1  
 Coordinate system: Principal  
 Extreme 1D: Global  
 Selection: All

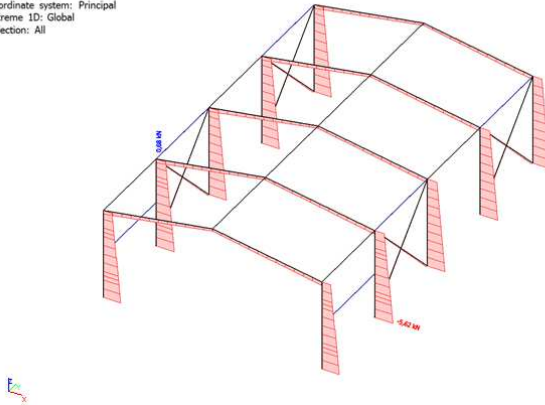

### 1.3. BG3 / Tot. value - M\_x

Values: M<sub>x</sub>  
 Linear calculation  
 Load case: BG1  
 Coordinate system: Principal  
 Extreme 1D: Global  
 Selection: All

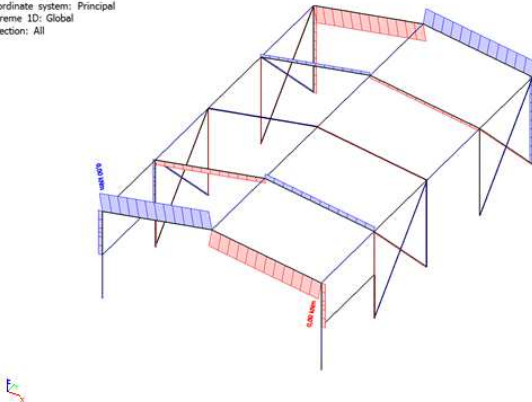

### 1.4. BG3 / Tot. value - M\_y

Values: M<sub>y</sub>  
 Linear calculation  
 Load case: BG1  
 Coordinate system: Principal  
 Extreme 1D: Global  
 Selection: All

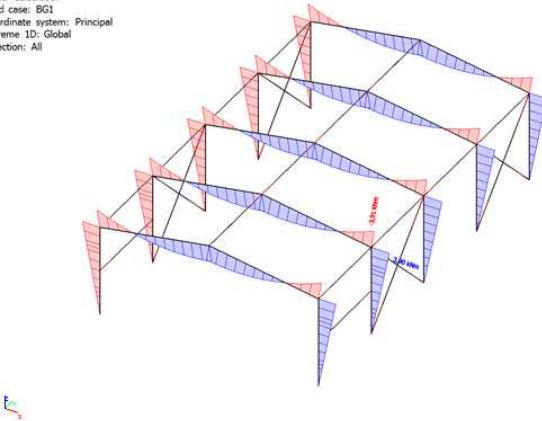

### 8.3.6. Report template

You can save a certain layout of a report as a report template. As soon as you have saved this template, you can import it in a project. The engineering report will then automatically generate all the items of the template according to the new project.

You can save the layout by navigating to the icon of SCIA Engineer and selecting the option 'Save as template'.

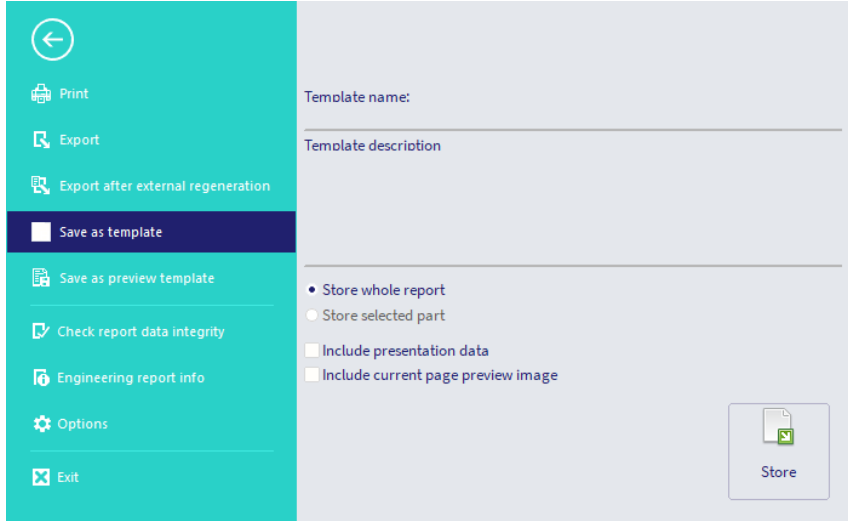

**NOTE: it is recommended that you save the template in the folder suggested by SCIA. That allows the software to easily apply the template in your future projects.**

The engineering report manager allows you to create a report according to a predefined template by SCIA Engineering or a user's defined template. This is shown in the following pictures.

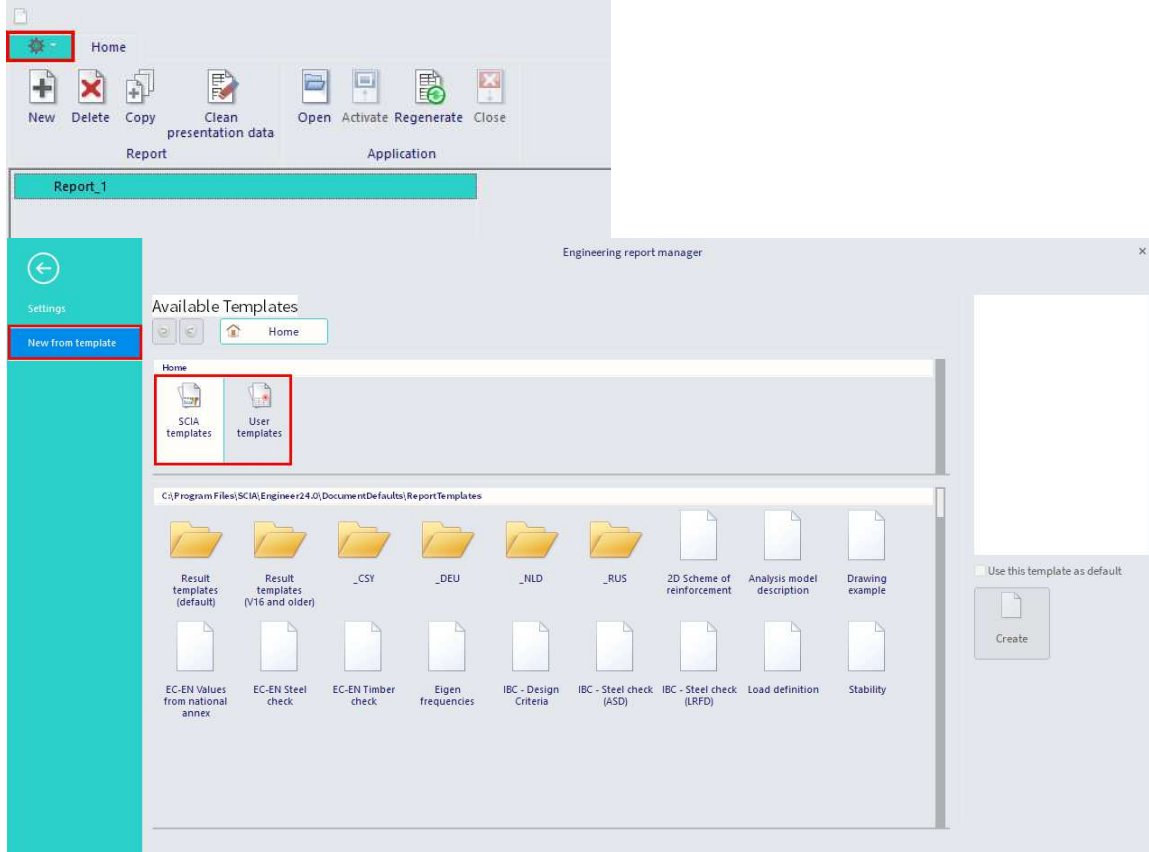



### 8.3.7. Export

You can export the engineering report to several formats as well. These formats are displayed in the following picture. You can access the export settings by navigating to the icon of SCIA Engineer and selecting the option 'Export'.

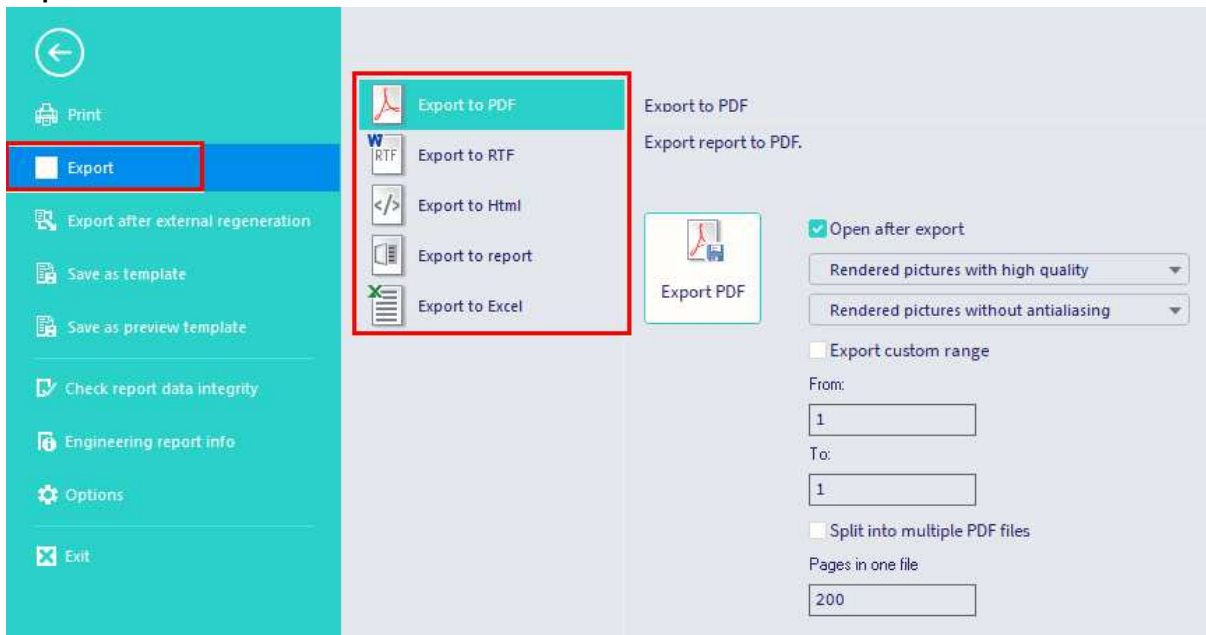

### 8.3.8. Print

You can print the engineering report by navigating to the icon of SCIA Engineer and selecting the option 'Print'. This is shown in the following picture.

